

AuCom

Ready
Run

Soft Starter

CSX
Series

CSX
Soft Starter

AuCom



CSX

Soft Starter

AuCom's CSX soft starters provide greater control over the starting and stopping of three phase motors. There are two product ranges: the CSX for a simple soft start control device, or the CSXi for an advanced soft start system complete with motor protection.

The CSX range is a Timed Voltage Ramp system that provides soft start and soft stop functionality in a very compact frame.

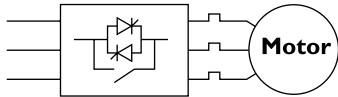

The AuCom CSX-030 soft starter

THE CSX IS A COMPACT AND COST EFFECTIVE SOFT STARTER SOLUTION. SIMPLE OPERATION AND A BUILT-IN BYPASS FUNCTION MAKE THE CSX SERIES A PLEASURE TO USE WITH MANY BENEFITS IN A TIDY PACKAGE.

COMPACT DESIGN

The CSX soft starter is a compact unit suitable for mounting in a switchboard or Motor Control Centre without the need for an external bypass contactor. At only 165 mm deep it is easy to mount in shallow switchboards.

For motors up to 60 A, soft starters can be mounted on a DIN-rail. Or the CSX may be mounted in a bank horizontally to use less space, often critical in certain switchboards.

SIMPLE TO USE

CSX series soft starters are easy to use with as only three adjustments to be made to get started:

- initial start time
- start ramp time
- soft stop ramp time

Adjustments are made using simple rotary switches. The CSXi soft starters allow more control over starts and stops with several adjustment controls.

BUILT-IN BYPASS FUNCTION

CSX soft starters are equipped with integrated bypass function. The internal bypass function allow CSX starters to be easily installed into switchboards or motor control cubicles without need for extra ventilation or external bypass contactors.

Makes installation simple, reduces ventilation requirements and overall installation cost.

CSXi

Soft Starter

The CSXi range is a Constant Current system with current measurement and control.

It provides a range of motor protection functions in addition to soft start and soft stop. Protections include motor overload, phase loss and excess start time.

The CSXi also features a programmable relay.

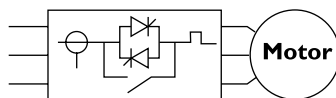

Contact your local distributor to learn how a CSX soft starter can benefit you today.



The AuCom CSXi-030 soft starter

PROTECTION

The CSXi has built-in thermal model motor overload protection. The motor current is continuously monitored and the expected temperature is calculated based on this monitored current.

The user sets the Motor Trip Class, and will trip when the calculated motor temperature reaches 105%.

An external motor protection device is not required when using a CSXi soft starter.





EASY TO OPERATE

Three adjustments can be made on the CSX soft starter:

- Initial Start Voltage
- Start Ramp Time
- Soft Stop Ramp Time

The CSXi has several adjustments for more control:

- Motor FLC
- Current limit
- Current ramp
- Stop time
- Motor trip class
- Phase sequence
- Excess start time
- Auxiliary relay selection



CSX control panel

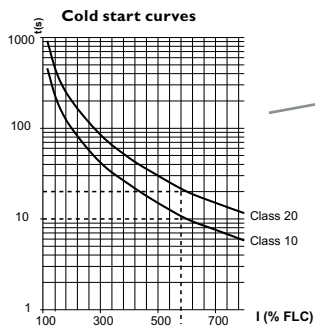
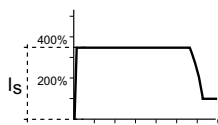
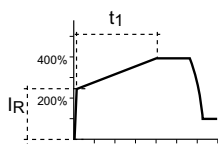
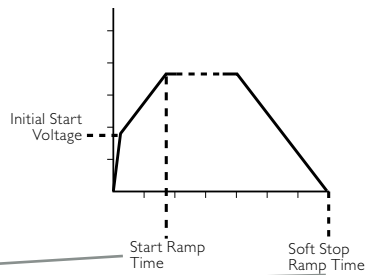

OFF = No overload protection
 Note: Trip class must be set to match installation limitations.



CSXi control panel

Motor FLC
 CSXi FLC

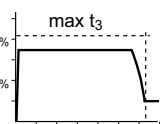
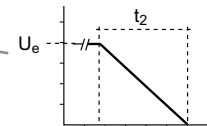

	FWD	ANY
L1 L2 L3	✓	✓
L1 L2 L3	✗	✓

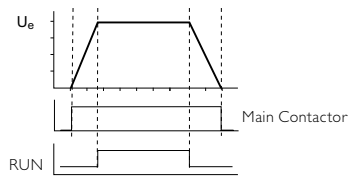



EQUI-VEC: BALANCED VECTOR CONTROL



BALANCED VECTOR CONTROL

In the past soft starters using two phase control caused extra heating in the motor and required higher starting currents because the output waveform was not symmetrical.

CSX soft starters control only two phases, but include Equi-Vec™ balanced vector control technology. Equi-Vec™ balances the output waveform to make it symmetrical. By balancing the waveform the CSX provides 3 phase like performance with compact soft starter technology.

This eliminates previous limitations of two phase controllers such as:

- Limited starts per hour
- Limited to light loads only
- Limited to motor < 55 kW

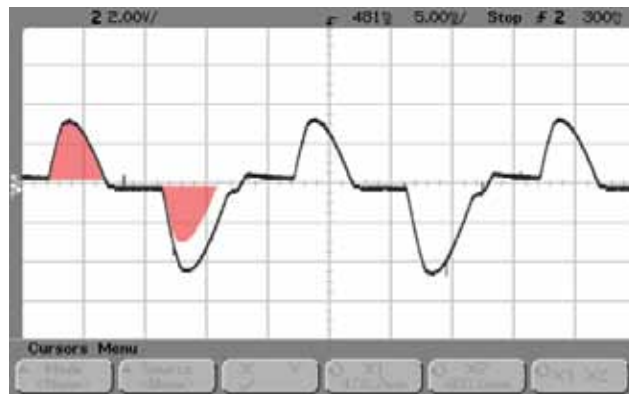

Typical 2-Phase control waveform

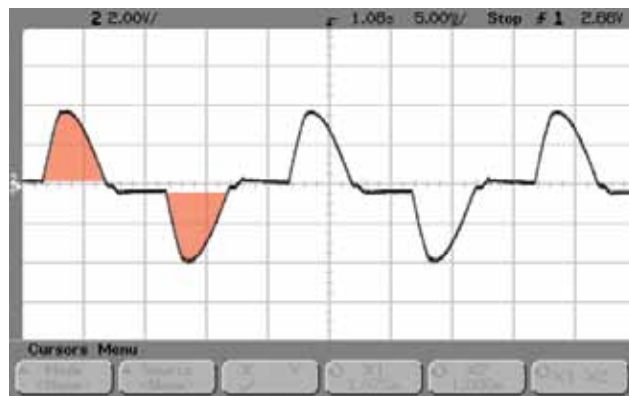

Equi-vec waveform

TRIP MESSAGES

The CSX series allows for fast diagnosis of a trip via two LEDs on the front of the unit. LEDs will flash to indicate the trip. (Note: some trip messages available only on the CSXi or with an optional accessory).

Indicator	Description
○	No control power
●	Ready
⊗	Tripped

Flash Code	Description
⊗ x 1	Power circuit
⊗ x 2	Excess Start Time
⊗ x 3	Motor Overload
⊗ x 4	Motor Thermistor
⊗ x 5	Current Imbalance
⊗ x 6	Supply Frequency
⊗ x 7	Phase Rotation
⊗ x 8	Network Communication Failure
⊗ x 9	Starter Communication Failure
⊗ x 10	Bypass Overload

* Protection feature standard





FEATURES



	CSX	CSXi
STARTING FUNCTIONS		
Timed Voltage Ramp	✓	
Current Limit		✓
Current Ramp		✓
STOPPING		
Coast To Stop	✓	✓
Soft Stop	✓	✓
PROTECTION		
Motor Overload		✓
Phase Loss		✓
Excess Start Time		✓
Phase Sequence		✓
Current Imbalance		✓
Motor Thermistor		✓
Power Circuit Fault	✓	✓
Supply Frequency	✓	✓
Instantaneous Overcurrent		✓
Bypass Overload		✓
Communications Failure	✓	✓

	CSX	CSXi
INTERFACE		
Fixed Relay Output (Main Contactor Relay)	✓	✓
Programmable Relay (Trip or Run)		✓
Run Relay Output	✓	
ACCESSORIES (OPTIONAL)		
Remote Operator	✓	✓
Modbus Interface	✓	✓
Profibus Interface	✓	✓
DeviceNet Interface	✓	✓
PC Software	✓	✓
Pump Application Module	✓	✓



SPECIFICATIONS

SPECIFICATIONS

General

Current Range 18 A ~ 200 A (nominal)
 Motor connection In-line
 Bypass Internal

Supply

Mains Voltage (A1, A2, A3)
 CSX-xxxx-V4 3 x 200 VAC ~ 440 VAC (± 10% / -15%)
 CSX-xxxx-V6 3 x 200 VAC ~ 575 VAC (± 10% / -15%)
 Control Voltage (A1, A2, A3)
 C1 110 ~ 240 VAC (+ 10% / -15%)
 or 380 ~ 440 VAC (+ 10% / -15%)
 C2 24 VAC AC/24 VDC (+ 20%)
 Mains Frequency 45 Hz to 66 Hz

Inputs

Start (terminal 01) Normally open, 300 VAC max
 Stop (terminal 02) Normally closed, 300 VAC max

Motor Thermistor (B4, B5) (CSXi only)

Relay Outputs

Main Contactor (13, 14) Normally Open
 6A, 30 VDC resistive / 2A, 400 VAC, ACII
 CSX Run Relay Normally Open
 CSXi Programmable Relay (23, 24) Normally Open
 6A, 30 VDC resistive / 2A, 400 VAC, ACII

Environmental

Protection
 CSX-007 ~ CSX-055 IP20
 CSX-075 ~ CSX-110 IP00
 Operating temperature -10 °C , max 60 °C with derating
 Humidity..... 5% to 95% Relative Humidity
 Conformal Coating Standard

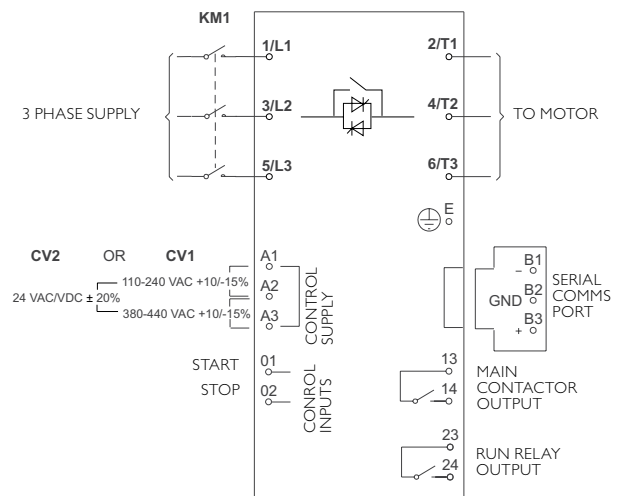

CSX electrical schematic

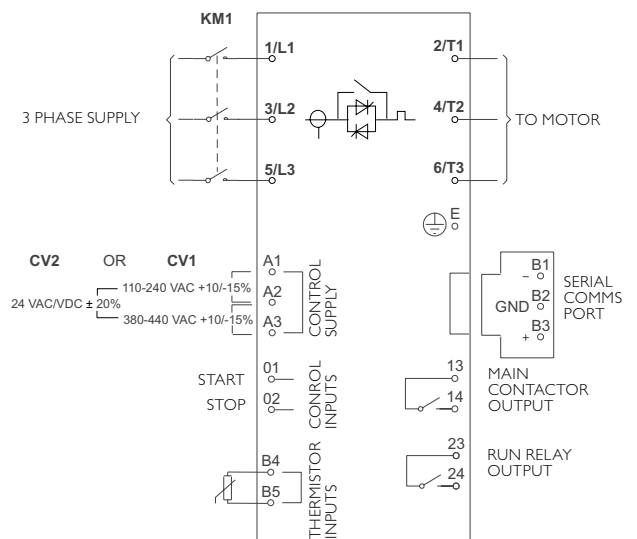

CSXi electrical schematic



THE COMPLETE RANGE



CSX-007 ~ CSX-030 CSX-075 ~ CSX-110 CSX-037 ~ CSX-055



CSXI-007 ~ CSXI-030 CSXI-075 ~ CSXI-110 CSXI-037 ~ CSXI-055

CSX AND CSXI CURRENT RATINGS

Model	AC53b 4-6:354 <1000 metres		AC53b 4-20:340 <1000 metres	
	40 °C	50 °C	40 °C	50 °C
CSX-007	18 A	17 A	17 A	15 A
CSX-015	34 A	32 A	30 A	28 A
CSX-018	42 A	40 A	36 A	33 A
CSX-022	48 A	44 A	40 A	36 A
CSX-030	60 A	55 A	49 A	45 A
Model	AC53b 4-6:594 <1000 metres		AC53b 4-20:580 <1000 metres	
	40 °C	50 °C	40 °C	50 °C
CSX-037	75 A	68 A	65 A	59 A
CSX-045	85 A	78 A	73 A	67 A
CSX-055	100 A	100 A	96 A	87 A
CSX-075	140 A	133 A	120 A	110 A
CSX-090	170 A	157 A	142 A	130 A
CSX-110	200 A	186 A	165 A	152 A

AuCom ratings are detailed using the AC53b utilisation code specified by IEC60947-4-2.

90 A: AC-53b 3.5-15 : 345

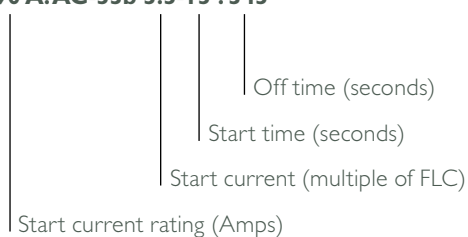



INSTALLATION

DIMENSIONS AND WEIGHTS

The design of the CSX allows for multiple units to be mounted side by side, or in a bank of starters due to the flexibility in cabling options. Convection cooled starters further reduce the overall size of your soft starter.

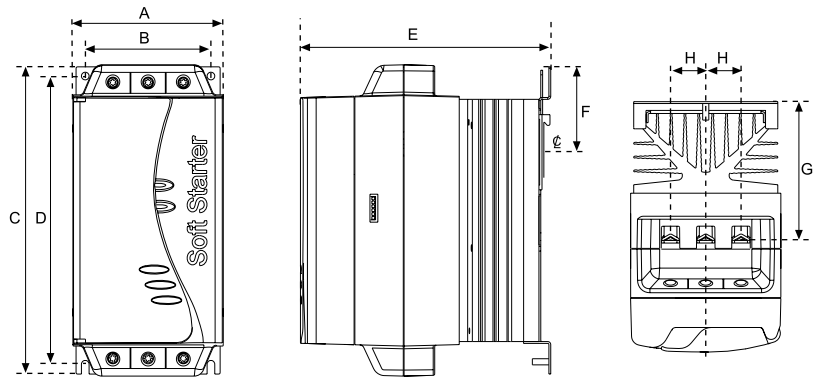

MODEL	A	B	C	D	E	F	G	H	WEIGHT kg (lbs)	
	mm (inches)	mm (inches)	mm (inches)	mm (inches)	mm (inches)	mm (inches)	mm (inches)	mm (inches)	CSX	CSXi
CSX-007	98	82	203	188	165	55	90.5	23	2.2	2.4
CSX-015	(3.86)	(3.23)	(7.99)	(7.40)	(6.50)	2.17	3.56	(0.9)	(4.85)	(5.29)
CSX-018										
CSX-022										
CSX-030										
CSX-037	145	124	215	196	193	-	110.5	37	4.0	4.3
CSX-045	(5.71)	(4.88)	(8.46)	(7.71)	(7.60)		(4.35)	(1.46)	(8.82)	(9.48)
CSX-055										
CSX-075	202	160	240	204	214	-	114.5	51	6.1	6.8
CSX-090	(7.95)	(6.30)	(9.45)	(8.03)	(8.43)		(4.50)	(2.0)	(13.45)	(14.99)
CSX-110										



ACCESSORIES/OPTIONAL FEATURES

REMOTE OPERATOR



The remote operator controls and monitors motor performance via a communication module including:

- Operational control (start, stop, reset)
- Status monitoring (start, run and trip)
- Performance monitoring (motor current and temperature)
- Trip Code display
- 4-20 mA analog output

COMMUNICATION MODULES



The CSX series supports USB and network communication using Profibus, DeviceNet and Modbus RTU protocols, via an easy-to-install communication interface module.

PC SOFTWARE

Using AuCom's own WinMaster software you can control and monitor your soft starter from your desktop computer.

FINGER GUARD KIT



This option ensures personnel safety by preventing accidental contact with live terminals. Finger guards provide IP20 protection when used with cable of diameter 22 mm or greater..



ABOUT AUCOM



SMART THINKING

We've been making soft starters since 1981 and we're still going strong. We're always talking to customers in order to improve technology to meet their needs. So our products have an international reputation for being the market leaders in soft start.

THE HIGHEST INTERNATIONAL STANDARDS

AuCom is accredited to ISO9001:2000, with all products designed and tested to international standards such as IEC 60947-4-2, UL 508, CCC and CISPR-II. All our products are thoroughly tested in certified facilities and in the field before release, and every soft starter is tested before despatch.

IT'S PERSONAL

No two people are the same, just as no two businesses are alike. We're proud that we treat each and every client as someone quite individual with their own set of business challenges. We have solutions for simple applications, and fully featured advanced starters for more complex requirements.

EXPERT PARTNERS

AuCom chooses partners that are committed to soft start and motor control, and regarded as experts in their local market. We work closely with our partners to ensure customers receive only the best advice.

HISTORY

AuCom introduced the first complete range of soft starters and since then, we have concentrated on fulfilling the promise that we lead the world in soft start technology and developing new products to keep improving motor performance.

We are proud of our attention to detail, flexibility and engineering skill, and are globally recognised as the world's leading specialist in soft starters.



AuCom manufacturing plant in Christchurch, New Zealand.

OTHER AUCOM PRODUCTS

AuCom offers a complete range of soft starters, with a solution for your soft starting requirement. Whether you need a simple product for starting only, or a comprehensive solution for your motor control and protection needs, you can trust AuCom to offer a product to match.

	Soft Start	Motor Protection	Advanced Interface	Internal Bypass	Power Range	Voltage Range
CSX	•			•	≤ 200 A	≤ 575 VAC
CSXi	•	•		•	≤ 200 A	≤ 575 VAC
IMS2	•	•	•		≤ 2361 A	≤ 690 VAC
EMX3	•	•	•	•	≤ 2400 A	≤ 690 VAC
MVS	•	•	•	•	≤ 600A *	≤ 13.8 kV
MVX	•	•	•	•	≤ 800A *	≤ 15 kV

* higher ratings available on request.

IMS2 DIGITAL SOFT STARTER



A comprehensive motor management system providing selectable soft start and soft stop control, advanced motor/load protection systems and extensive control & interface features.

EMX3 ADVANCED SOFT STARTER



A complete motor management system providing constant current, and current ramp as well as the new XLR-8, Adaptive Acceleration Control, available only from AuCom.

MVS MEDIUM VOLTAGE SOFT STARTER



An advanced motor management system for medium voltage motors. MVS soft starters provide a full range of soft start control, motor/load protection and other features.

MVX MEDIUM VOLTAGE SOFT STARTER



The MVX is among the smallest medium voltage soft starter in its class. To ensure that your staff and plant are safe from arc faults, MVX is the only choice.

For more information on AuCom products, contact your local distributor:

AuCom

AuCom Electronics Ltd.
 123 Wrights Road
 PO Box 80208
 Christchurch 8440
 New Zealand
 T +64 3 338 8280
 F +64 3 338 8104
 E salesupport@aucom.com
 W www.aucom.com

I.1 Istruzioni di sicurezza

Le istruzioni di sicurezza non possono coprire tutte le possibili cause di danni alle apparecchiature, ma possono evidenziare quelle più comuni. L'installatore ha la responsabilità di leggere e comprendere tutte le istruzioni presenti in questo manuale prima di installare, gestire o effettuare la manutenzione dell'avviatore statico, di seguire le buone prassi per i sistemi elettrici con l'applicazione di adeguati dispositivi di protezione personale e di chiedere suggerimenti prima di utilizzare questa apparecchiatura in modo diverso da quanto descritto nel presente manuale.

- Isolare completamente l'avviatore statico dall'alimentazione elettrica prima di operare sull'avviatore o sul motore.
- I cavi che vanno agli ingressi del controllo devono essere separati dalla tensione di rete e dai cavi del motore.
- Le bobine di alcuni contattori elettronici non sono adatti alla commutazione diretta con relè con montaggio su circuito stampato. Rivolgersi al fornitore o al fabbricante del contattore per verificarne l'idoneità.
- Non applicare tensioni inadeguate ai morsetti di controllo.
- Non collegare condensatori di rifasamento all'uscita degli avviatori statici CSX. Se si utilizza un sistema di rifasamento a inserzione statica, questo deve essere collegato al lato alimentazione dell'avviatore statico.

Gli esempi e i grafici nel presente manuale hanno scopo puramente illustrativo. Le informazioni contenute in questo manuale possono essere modificate in qualsiasi momento senza preavviso. In nessun caso potrà essere accettata la responsabilità per danni diretti, indiretti o consequenziali derivanti dall'uso improprio di questa apparecchiatura.



ATTENZIONE - Pericolo di folgorazione

Gli avviatori statici CSX contengono tensioni pericolose quando sono collegati alla tensione di rete. L'installazione elettrica deve essere effettuata esclusivamente da elettricisti qualificati. L'installazione inadeguata del motore o dell'avviatore statico può provocare guasti, gravi lesioni o morte. Seguire le norme di sicurezza elettrica locali e quelle riportate nel presente manuale.



MESSA A TERRA E PROTEZIONE DEI CIRCUITI DI DERIVAZIONE

È responsabilità dell'utente o dell'installatore realizzare un sistema adeguato di messa a terra e di protezione del circuito di derivazione secondo le norme vigenti in materia di sicurezza elettrica.



CORTO CIRCUITO

Gli avviatori statici CSX non sono a prova di cortocircuito. Dopo un grave sovraccarico o un cortocircuito, il funzionamento dell'avviatore statico deve essere completamente verificato da un tecnico di assistenza autorizzato.

- FR Ce manuel est également disponible en français à partir de www.aucom.com.
- DE Dieses Handbuch ist auch in deutscher Sprache aus www.aucom.com.
- PT Este manual também está disponível em Português sobre o CD incluído.
- ES Este manual también está disponible en español a partir de www.aucom.com.
- ZH 该手册也可在中国从 www.aucom.com.

Section 2 Installazione meccanica

2.1 Dimensioni e pesi

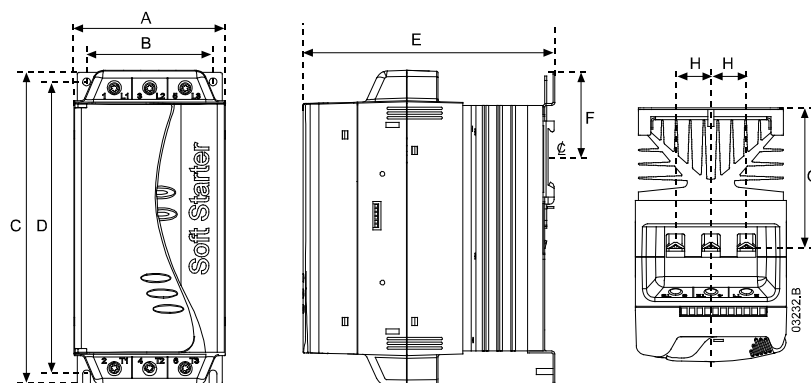

Modello	A mm (pollici)	B mm (pollici)	C mm (pollici)	D mm (pollici)	E mm (pollici)	F mm (pollici)	G mm (pollici)	H mm (pollici)	kg (lb)
CSX-007 CSX-015 CSX-018 CSX-022 CSX-030	98 (3.86)	82 (3.23)	203 (7.99)	188 (7.40)	165 (6.50)	55 (2.17)	90.5 (3.56)	23 (0.9)	2.2 (4.85)
CSX-037 CSX-045 CSX-055	145 (5.71)	124 (4.88)	215 (8.46)	196 (7.71)	193 (7.60)	-	110.5 (4.35)	37 (1.46)	4.0 (8.82)
CSX-075 CSX-090 CSX-110	202 (7.95)	160 (6.30)	240 (9.45)	204 (8.03)	214 (8.43)	-	114.5 (4.50)	51 (2.0)	6.1 (13.45)

2.2 Modalità d'installazione

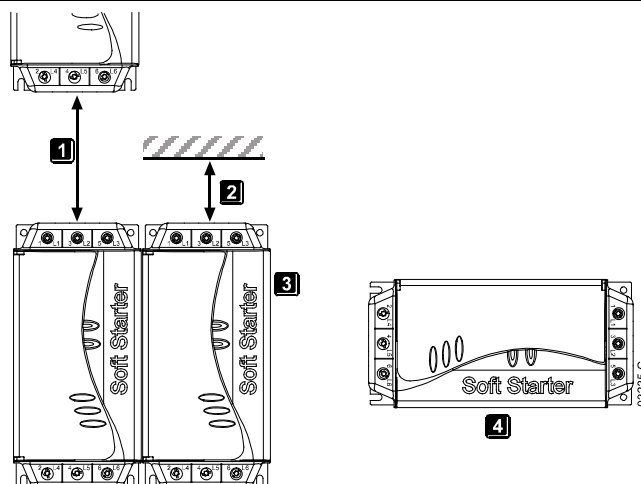

1	CSX-007 ~ CSX-055: lasciare 100 mm (3,9 pollici) tra un avviatore statico e l'altro. CSX-075 ~ CSX-110: lasciare 200 mm (7,9 pollici) tra un avviatore statico e l'altro.
2	CSX-007 ~ CSX-055: lasciare 50 mm (2,0 pollici) tra l'avviatore statico e le superfici di altri oggetti. CSX-075 ~ CSX-110: lasciare 200 mm (7,9 pollici) tra l'avviatore statico e le superfici di altri oggetti.
3	Gli avviatori statici possono essere montati affiancati senza lasciare spazi intermedi.
4	L'avviatore statico può essere montato orizzontalmente. Declassare la corrente nominale dell'avviatore statico del 15%.

Section 3 Installazione elettrica

3.1 Terminazioni di potenza

	L1/1, L2/3, L3/5, T1/2, T2/4, T3/6 mm ² (AWG)			A1, A2, A3, 01, 02, B4, B5, 13, 14, 23, 24 mm ² (AWG)	
	007 ~ 030	037 ~ 055	075 ~ 110	007 ~ 110	
	10 - 35 (8 - 2)	 25 - 50 (4 - 1/0)	N.A.	 11 26 Ø 8.5 (1.02)(0.33)	 0.14 - 1.5 (26 - 16)
	10 - 35 (8 - 2)	 25 - 50 (4 - 1/0)	N.A.	 6 (0.24)	0.14 - 1.5 (26 - 16)
	Torx (T20) 3 Nm 2.2 ft-lb	Torx (T20) 4 Nm 2.9 ft-lb	N.A.	N.A.	
	7 mm 3 Nm 2.2 ft-lb	7 mm 4 Nm 2.9 ft-lb	N.A.	3.5 mm 0.5 Nm max 4.4 in-lb max	

3.2 Tensioni di controllo

Gli avviatori statici CSX possono essere forniti con due configurazioni di tensione di controllo:
 CSX-xxx-xx-C1 110-240 VAC (+ 10% / - 15%) o 380-440 VAC (+ 10% / - 15%)
 CSX-xxx-xx-C2 24 VAC/VDC (± 20%)



ATTENZIONE

Applicare sempre la tensione di controllo prima o allo stesso tempo della tensione di rete.



ATTENZIONE

Con alimentazione a 24 VAC/VDC utilizzare contatti predisposti per bassa tensione e bassa corrente (con placcatura in oro o simile).

3.3 Circuiti di controllo

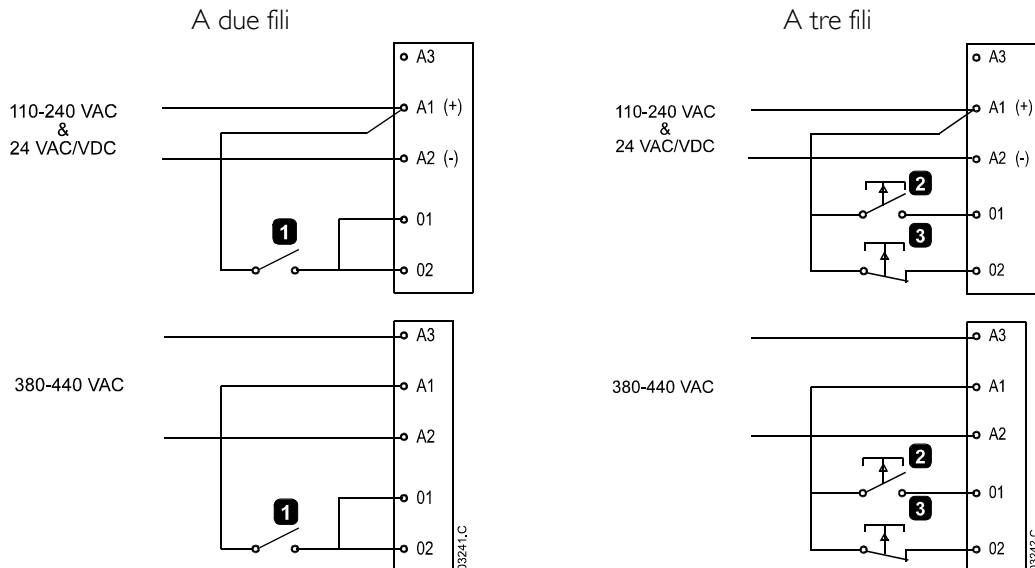

1	Avviamento/arresto. Per il ripristino in seguito a un intervento, aprire e richiudere 02.
2	Start (Avviamento).
3	Stop (Arresto). Per il ripristino in seguito a un intervento, aprire e richiudere 02.



ATTENZIONE

Isolare completamente l'avviatore statico dall'alimentazione elettrica prima di operare sull'avviatore o sul motore. I terminali di controllo possono trovarsi al potenziale della tensione di fase.

3.4 Uscite

Uscita Contattore di Rete

L'uscita Contattore di rete (terminali 13, 14) si chiude appena l'avviatore statico riceve un comando di avviamento e rimane chiusa fino all'arresto in folle del motore o fino al termine di un arresto graduale. L'uscita Contattore di rete si aprirà anche in caso di allarme dell'avviatore statico.

L'uscita Contattore di rete può essere utilizzata per controllare direttamente la bobina di un contattore di rete.

Uscita Run (Marcia)

Il relè di uscita Run (Marcia) (terminali 23, 24) può essere utilizzato per segnalare lo stato di marcia (Run). Questo relè è normalmente aperto.

Il relè interviene quando l'avviamento graduale è stato completato, i relè di bypass sono chiusi e al motore è applicata la tensione di regime. Il relè può essere utilizzato per far funzionare un contattore per condensatori di correzione del fattore di potenza o per segnalare lo stato di marcia dell'avviatore statico a un sistema di automazione.

3.5 Schemi elettrici

Figura 1: L'avviatore statico installato con interruttore automatico di protezione del motor



Figura 2: Avviatore statico installato con interruttore automatico e contattore di rete di protezione del motor



Figura 3: Avviatore statico installato con interruttore automatico, protezione dal sovraccarico del motore e contattore di rete di protezione del motor

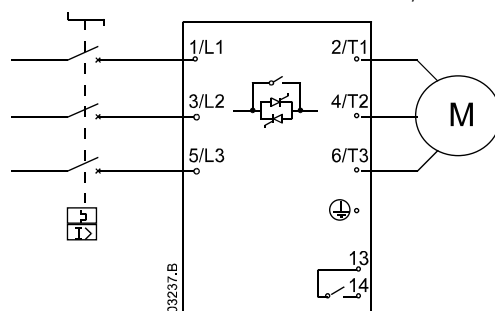

M	Motore (trifase)
KM1	Contattore di rete
13, 14	Uscita Contattore di Rete

Section 4 Regolazioni

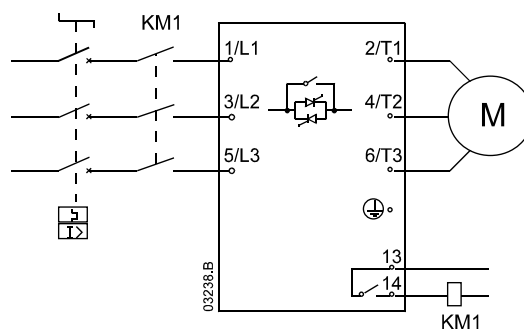
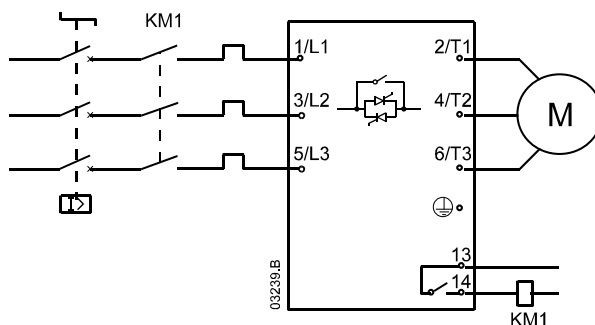
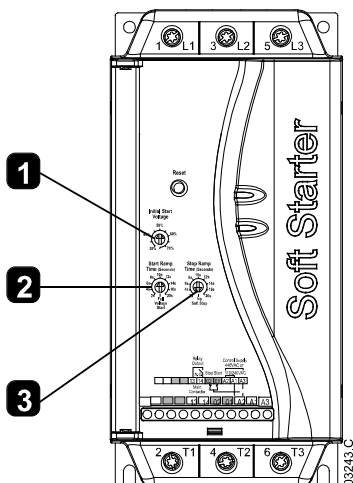

- 1** Tensione di avviamento iniziale
- 2** Tempo di avviamento iniziale
- 3** Tempo di arresto graduale

1 Tensione di avviamento iniziale

Selezionare la tensione di avviamento iniziale (A).

Applicazione	Tensione di avviamento iniziale suggerita
Pompa centrifuga	50%
Pompa a immersione	60%
Compressore a vite	70%
Convogliatore	
Frantoio	
Ventilatore	
Altre applicazioni	

2 Tempo di avviamento iniziale

Selezionare il Tempo di avviamento iniziale (B).

La rampa di avviamento stabilisce il tempo impiegato dall'avviatore statico per portare il valore della tensione da quello di partenza a quello di regime.

Il Tempo di avviamento iniziale non controlla il tempo necessario al motore per portarsi alla velocità di regime.

1. Impostare il Tempo di avviamento iniziale a 20 secondi.
2. Impostare la Tensione di avviamento iniziale secondo le esigenze dell'applicazione.
3. Collegare un dispositivo di monitoraggio della corrente sull'uscita T1.
4. Avviare il motore in condizioni di carico normali. Registrare il tempo che la corrente impiega per portarsi sotto il valore della corrente nominale del motore a pieno carico (t_i); quindi arrestare il motore.
5. Impostare il Tempo di avviamento iniziale = t_i .

NOTA

Il Tempo di avviamento iniziale deve essere abbastanza lungo da permettere al motore di raggiungere la velocità di regime prima che l'avviatore statico vada in modalità bypass.

3 Tempo di arresto graduale

Selezionare il tempo di rampa di Arresto graduale (C).

L'arresto graduale prolunga il tempo impiegato dall'avviatore statico per portare a zero la tensione.

Il tempo di rampa non controlla il tempo necessario per l'arresto completo del motore.

Section 5 Risoluzione dei problemi

5.1 LED

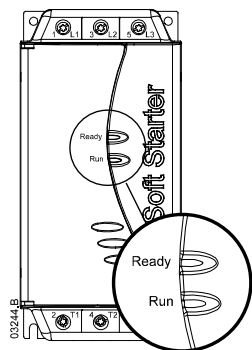

LED Staus (Stato)	Ready (Pronto)	Run (Marcia)
Spento	Alimentazione di comando assente	Motore non in funzione
Acceso	Pronto	Motore in funzione a velocità di regime
Flash (Lampeggiante)	Avviatore in allarme	Motore in avviamento/arresto

5.2 Codici di allarme

Il LED Pronto lampeggia un numero di volte diverso a seconda del motivo dell'allarme dando così indicazione di quale motivo si tratta.

Ready LED	Descrizione
☀ × 1	Circuito di alimentazione: controllare l'alimentazione di rete (L1, L2, L3), il circuito del motore (T1, T2, T3), gli SCR dell'avviatore statico e i relè di bypass.
☀ × 6	Frequenza di alimentazione: verificare che sia presente la tensione di rete e che la frequenza di alimentazione sia compresa nel range ammesso.
☀ × 8	Guasto della comunicazione di rete (tra dispositivo d'interfaccia e rete): controllare i collegamenti, le impostazioni e la configurazione della rete.
☀ × 9	Guasto della comunicazione di rete dell'avviatore (tra l'avviatore e il dispositivo d'interfaccia): togliere e inserire nuovamente il dispositivo d'interfaccia accessorio.

Protezione dalla frequenza di alimentazione

L'avviatore statico va in allarme se la frequenza di alimentazione supera i 72 Hz o scende al di sotto dei 40 Hz per più di cinque secondi durante il funzionamento. Non è possibile modificare questi punti di allarme. In modalità pre-avviamento, avviamento e arresto sono validi entrambi i limiti di frequenza alto e basso senza ritardo temporale.

Si verificherà un allarme a causa della frequenza di alimentazione se:

- Si verifica una perdita delle tre fasi in ingresso mentre l'avviatore statico è in funzione
- Tutte e tre le fasi in ingresso scendono sotto ai 120 VAC all'avviamento o mentre è in funzione l'avviatore statico
- Il contattore di linea si apre mentre è in funzione

5.3 Reset (Ripristino)

È possibile ripristinare lo stato dell'avviatore dopo un allarme premendo il pulsante Reset (Ripristino) sull'avviatore statico, inviando un comando di Reset via comunicazione seriale, o scambiando gli ingressi del comando.

Per il reset tramite gli ingressi di controllo, è necessario far passare da chiuso ad aperto l'ingresso Stop (Arresto) (02) dell'avviatore statico.

- In un controllo a tre fili, utilizzare il pulsante esterno di Stop (Arresto) per aprire momentaneamente l'ingresso Stop (A1 aperto-02 aperto).
- Nel controllo a due fili, se l'avviatore statico è andato in allarme in presenza di un segnale di Start (Avvio), rimuovere il segnale di Start (da A1 a 01, 02 aperti).

Il pulsante Reset (Ripristino) è collocato sulla parte anteriore dell'unità, sopra i commutatori di regolazione.

L'avviatore statico andrà in allarme nuovamente se la causa dell'intervento persiste.

Section 6 Accessori

6.1 Kit Salvadito

È possibile richiedere dei salvadito per la sicurezza del personale e utilizzarli sui modelli di avviatori statici CSX 075~110. I salvadito sono inseriti sui terminali dell'avviatore statico per impedire il contatto accidentale con i terminali sotto tensione. I salvadito forniscono la protezione IP20 se utilizzato con cavo con diametro 22 mm o maggiore.

6.2 Operatore remoto

La funzionalità Operatore remoto può controllare e monitorare le prestazioni dell'avviatore statico. La funzionalità comprende:

- Controllo operativo (Start [Avviamento], Stop [Arresto], Reset, Quick Stop [Arresto rapido])
- Monitoraggio dello stato dell'avviatore (Ready [Pronto], Starting [In avvio], Running [In marcia], Stopping [In arresto], Tripped [In allarme])
- Visualizzazione del codice di intervento

6.3 Dispositivo d'interfaccias di comunicazione

Gli avviatori statici CSX sono compatibili con sistemi di comunicazione di rete che utilizzano protocolli Profibus, DeviceNet e Modbus RTU.

6.4 Software per PC

Il WinMaster può essere utilizzato con avviatori statici di AuCom per fornire le seguenti funzioni per reti con fino a 99 avviatori statici:

- Controllo operativo (Start [Avviamento], Stop [Arresto], Reset, Quick Stop [Arresto rapido])
- Monitoraggio dello stato dell'avviatore (Ready [Pronto], Starting [In avvio], Running [In marcia], Stopping [In arresto], Tripped [In allarme])

Per utilizzare WinMaster con CSX, è necessario che l'avviatore statico sia dotato di Dispositivo d'interfaccia Modbus (PIM-MB-01) o di un (PIM-RO-01) della tastiera remota.

Section 7 Specifiche

7.1 Dati tecnici generali

Alimentazione di rete

Tensione di rete (L1, L2, L3)	
CSX-xxx-V4	3 x 200 VAC ~ 440 VAC (+ 10% / - 15%)
CSX-xxx-V6	3 x 200 VAC ~ 575 VAC (+ 10% / - 15%)
Frequenza di rete (all'avviamento)	da 45 Hz a 66 Hz
Tensione nominale di isolamento	600 VAC
Denominazione modulo	Modulo Avviatore di motore con bypass a semiconduttore I

Tensione di rete (A1, A2, A3)

CSX-xxx-xx-C1	110-240 VAC (+ 10% / - 15%) o 380-440 VAC (+ 10% / - 15%)
CSX-xxx-xx-C2	24 VAC/VDC ($\pm 20\%$)
Assorbimento di corrente (in marcia)	< 100 mA
Consumo di corrente (spunto)	
CSX-xxx-xx-C1	10 A
CSX-xxx-xx-C2	2 A

Ingressi

Start (Avviamento) (terminale 01)	Normalmente aperto 150 k Ω @ 300 VAC and 5,6 k Ω @ 24 VAC/VDC
Stop (Arresto) (terminale 02)	Normalmente chiuso 150 k Ω @ 300 VAC and 5,6 k Ω @ 24 VAC/VDC

Uscite

Contattore di rete (terminali 13, 14)	Normalmente aperto 6 A, 30 VDC resistivo / 2 A, 400 VAC, ACI I
Relè Run (Marcia) (terminali 23, 24)	Normalmente aperto 6 A, 30 VDC resistivo / 2 A, 400 VAC, ACI I

Condizioni ambientali

Livello di protezione da CSX-007 a CSX-055	IP20
Livello di protezione da CSX-075 a CSX-110	IP00
Temperatura di funzionamento	da -10 °C a +60 °C
Temperatura di stoccaggio	da -25 °C a +60 °C (a +70 °C per meno di 24 ore)
Umidità relativa	da 5% a 95%
Livello di inquinamento	Livello di inquinamento 3
Vibrazioni	Test Fc Sinusoidale CEI 60068 da 4 Hz a 13,2 Hz: spostamento ± 1 mm da 13,2 Hz a 200 Hz: $\pm 0,7$ g

Emissioni EMC

Classe dell'apparecchiatura (EMC)	Classe A
Emissioni a radiofrequenza condotte	da 0,15 MHz a 0,5 MHz: < 90 dB (μ V) da 0,5 MHz a 5 MHz: < 76 dB (μ V) da 5 MHz a 30 MHz: 80-60 dB (μ V)
Emissioni a radiofrequenza condotte	da 30 MHz a 230 MHz: < 30 dB (μ V) da 230 MHz a 1000 MHz: < 37 dB (μ V)

Questo prodotto è stato classificato come apparecchiatura Classe A. L'utilizzo di questo prodotto in ambienti domestici può provocare radiointerferenze che richiedono ulteriori provvedimenti per la riduzione delle interferenze.

Immunità elettromagnetica (EMC)

Scarica elettrostatica	4 kV scarica a contatto, 8 kV scarica in aria
Campo elettromagnetico a radiofrequenza	da 0,15 MHz a 1000 MHz: 140 dB (μ V)
Tensione nominale di tenuta all'impulso (transitori veloci 5/50 ns)	2 kV tra linea e terra, 1 kV tra linea e linea
Caduta di tensione e breve interruzione	100 ms (al 40% della tensione nominale)
Armoniche e distorsione	CEI61000-2-4 (Classe 3), EN/CEI61800-3

Cortocircuito

Corrente nominale di cortocircuito da CSX-007 a CSX-037	5 kA
Corrente nominale di cortocircuito da CSX-045 a CSX-110	10 kA

Dissipazione del calore

All'avviamento	3 Watt / ampere
Durante la marcia	10 Watt

Certificazioni

C✓	IEC 60947-4-2
UL / C-UL	UL 508
CE IEC	60947-4-2
CCC	GB 14048.6
Lloyds	CEI 60947-4-2

Vita operativa

CSX-007~055	1.000.000 cicli operativi
CSX-075~110	30.000 cicli operativi

7.2 Codice modello

CSX - -

Tensione del controllo
 C1 = 110-240 VAC & 380-440 VAC
 C2 = 24 VAC/VDC

Tensione di rete
 V4 = 200 ~ 440 VAC
 V6 = 200 ~ 575 VAC

Classificazione @400 kW nominali VAC
 ≤ 30 AC53b 4-6:354
 ≥ 37 AC53b 4-6:594

7.3 Correnti nominali

	AC53b 4-6:354 < 1000 metri		AC53b 4-20:340 < 1000 metri	
	40 °C	50 °C	40 °C	50 °C
CSX-007	18 A	17 A	17 A	15 A
CSX-015	34 A	32 A	30 A	28 A
CSX-018	42 A	40 A	36 A	33 A
CSX-022	48 A	44 A	40 A	36 A
CSX-030	60 A	55 A	49 A	45 A
	AC53b 4-6:594 < 1000 metri		AC53b 4-20 580 < 1000 metri	
	40 °C	50 °C	40 °C	50 °C
CSX-037	75 A	68 A	65 A	59 A
CSX-045	85 A	78 A	73 A	67 A
CSX-055	100 A	100 A	96 A	87 A
CSX-075	140 A	133 A	120 A	110 A
CSX-090	170 A	157 A	142 A	130 A
CSX-110	200 A	186 A	165 A	152 A

7.4 Fusibili a semiconduttore

Con gli avviatori statici CSX è possibile utilizzare fusibili a semiconduttore per ridurre la possibilità di danni agli SCR a causa di transitori con sovraccarico di corrente e per coordinamento Tipo 2. Sono stati eseguiti test per verificare che gli avviatori statici CSX siano idonei a funzionare in coordinamento Tipo 2 con fusibili a semiconduttore. I fusibili a semiconduttore Bussman e Ferraz più indicati sono riportati di seguito:

Modello	SCR I ² T (A ² S)	Fusibile Ferraz Tipo Europeo/IEC (Tipo Nord Americano)	Fusibile Bussmann A corpo quadrato (170 M)	Fusibile Bussmann Tipo inglese (BS88)
CSX-007	1150	6.6URD30xxxA0063 (A070URD30xxx0063)	170M-1314	63 FE
CSX-015	8000	6.6URD30xxxA0125 (A070URD30xxx0125)	170M-1317	160 FEE
CSX-018	10500	6.6URD30xxxA0160 (A070URD30xxx0160)	170M-1318	160 FEE
CSX-022	15000	6.6URD30xxxA0160 (A070URD30xxx0160)	170M-1318	180 FM
CSX-030	18000	6.6URD30xxxA0160 (A070URD30xxx0160)	170M-1319	180 FM
CSX-037	51200	6.6URD30xxxA0250 (A070URD30xxx0250)	170M-1321	250 FM
CSX-045	80000	6.6URD30xxxA0315 (A070URD30xxx0315)	170M-1321	250 FM
CSX-055	97000	6.6URD30xxxA0315 (A070URD30xxx0315)	170M-1321	250 FM
CSX-075	168000	6.6URD31xxxA0450 (A070URD31xxx0450)	170M-1322	500 FMM
CSX-090	245000	6.6URD31xxxA0450 (A070URD31xxx0450)	170M-3022	500 FMM
CSX-110	320000	6.6URD31xxxA0450 (A070URD31xxx0450)	170M-3022	500 FMM

xxx = tipo a coltello. Rivolgersi a Ferraz per conoscere le opzioni disponibili.



Contents

1.	Caution Statements.....	2
2.	Mechanical Installation.....	3
3.	Electrical Installation	4
4.	Adjustments	7
5.	Troubleshooting.....	8
6.	Accessories.....	9
7.	Specifications.....	10

The examples and diagrams in this manual are included solely for illustrative purposes. The information contained in this manual is subject to change at any time and without prior notice. In no event will responsibility or liability be accepted for direct, indirect or consequential damages resulting from the use or application of this equipment.

- FR** Ce manuel est également disponible en français à partir de www.aucom.com.
- DE** Dieses Handbuch ist auch in deutscher Sprache aus www.aucom.com.
- IT** Questo manuale è disponibile anche in italiano da www.aucom.com.
- PT** Este manual também está disponível em Português no site www.aucom.com.
- ES** Este manual también está disponible en español a partir de www.aucom.com.
- ZH** 该手册也可在中国从www.aucom.com.

1. Caution Statements

Caution Statements cannot cover every potential cause of equipment damage but can highlight common causes of damage. It is the installer's responsibility to read and understand all instructions in this manual prior to installing, operating or maintaining the equipment, to follow good electrical practice including applying appropriate personal protective equipment and to seek advice before operating this equipment in a manner other than as described in this manual.

- Isolate the CSX completely from the power supply before attempting any work on the CSX or motor.
- Cables to the control inputs must be segregated from mains voltage and motor cabling.
- Some electronic contactor coils are not suitable for direct switching with PCB mount relays. Consult the contactor manufacturer/supplier to confirm suitability.
- Do not apply incorrect voltages to the control input terminals.
- Do not connect power factor correction capacitors to the output of CSX soft starters. If static power factor correction is employed, it must be connected to the supply side of the soft starter.



WARNING - ELECTRICAL SHOCK HAZARD

The CSX contains dangerous voltages when connected to mains voltage. Only a qualified electrician should carry out the electrical installation. Improper installation of the motor or the CSX may cause equipment failure, serious injury or death. Follow this manual and local electrical safety codes.



AVERTISSEMENT - DANGER D'ELECTROCUTION

Le CSX contient des tensions dangereuses lorsqu'il est raccordé à l'alimentation secteur. Seul un électricien compétent peut effectuer l'installation électrique. Une mauvaise installation du moteur ou du CSX peut déclencher une panne d'équipement, provoquer de graves blessures ou même la mort. Suivre les instructions de ce manuel et des codes locaux concernant la sécurité électrique.



GROUNDING AND BRANCH CIRCUIT PROTECTION

It is the responsibility of the user or person installing the CSX to provide proper grounding and branch circuit protection according to local electrical safety codes.



SHORT CIRCUIT

The CSX is not short circuit proof. After severe overload or short circuit, the operation of the CSX should be fully tested by an authorised service agent.

2. Mechanical Installation

2.1 Dimensions and Weights

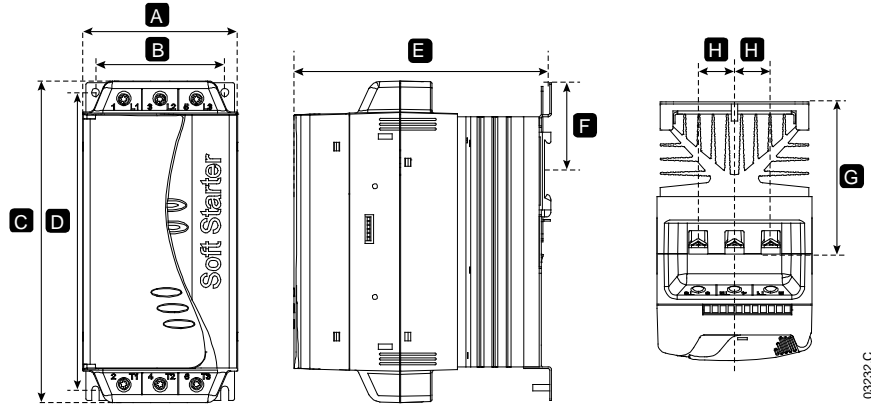

Model	Width mm (inch)		Height mm (inch)		Depth mm (inch)	mm (inch)	mm (inch)	mm (inch)	Weight kg (lb)
	A	B	C	D	E	F	G	H	
CSX-007									
CSX-015									
CSX-018	98	82	201	188	165	55	90.5	23	2.1
CSX-022	(3.85)	(3.22)	(7.91)	(7.40)	(6.49)	(2.16)	(3.6)	(0.9)	(4.6)
CSX-030									
CSX-037									
CSX-045	145	124	215	196	193	-	110.5	37	3.8
CSX-055	(5.70)	(4.88)	(8.46)	(7.71)	(7.59)		(4.4)	(1.5)	(8.4)
CSX-075									
CSX-090	200	160	240	216	214	-	114.5	51	6.1
CSX-110	(7.87)	(6.30)	(9.44)	(8.50)	(8.43)		(4.5)	(2.0)	(13.5)

2.2 Physical Installation

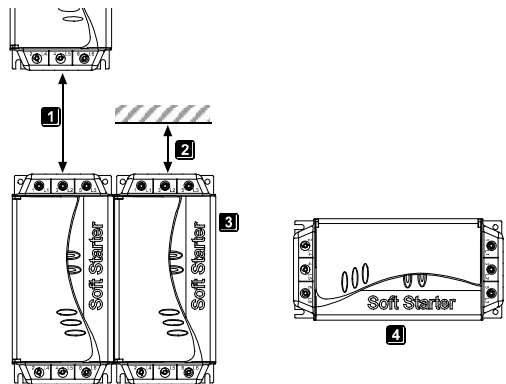

1	CSX-007 ~ CSX-055: Allow 100 mm (3.9 inch) between soft starters. CSX-075 ~ CSX-110: Allow 200 mm (7.9 inch) between soft starters.
2	CSX-007 ~ CSX-055: Allow 50 mm (2.0 inch) between the soft starter and solid surfaces. CSX-075 ~ CSX-110: Allow 200 mm (7.9 inch) between the soft starter and solid surfaces.
3	Soft starters may be mounted side by side with no clearance (that is, if mounted without communications modules).
4	The soft starter may be mounted on its side. Derate the soft starter's rated current by 15%.

3. Electrical Installation

3.1 Power Terminations

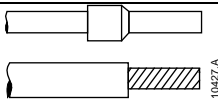
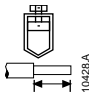
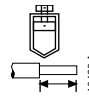
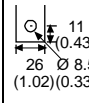
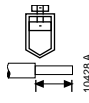
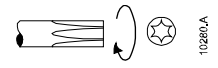
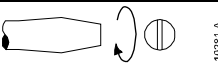
	L1/1, L2/3, L3/5, T1/2, T2/4, T3/6 mm ² (AWG)			A1, A2, A3, 01, 02, 13, 14, 23, 24 mm ² (AWG)	
	007 - 030	037 - 055	075 - 110	007 - 110	
	10 - 35 (8 - 2)  14 mm (0.55 inch)	25 - 50 (4 - 1/10)  14 mm (0.55 inch)	N.A.	 11 26 Ø 8.5 (1.02)(0.33) mm (inch)	0.14 - 1.5 (26 - 16)  6 mm (0.24 inch)
	Torx (T20) 3 Nm 2.2 ft-lb	Torx (T20) 4 Nm 2.9 ft-lb	n/a	n/a	
	7 mm 3 Nm 2.2 ft-lb	7 mm 4 Nm 2.9 ft-lb	n/a	3.5 mm 0.5 Nm max 4.4 in-lb max	

3.2 Control Voltages

CSX soft starters can be supplied in either of two control voltage configurations:

CSX-xxx-xx-C1 110-240 VAC (+ 10% / - 15%) or 380-440 VAC (+ 10% / - 15%)

CSX-xxx-xx-C2 24 VAC/VDC (± 20%)



WARNING

Always apply control voltage before (or with) mains voltage.



AVERTISSEMENT

Toujours appliquer la tension de commande avant (ou en même temps que) la tension secteur.



CAUTION

With 24 VAC/VDC use contacts rated for low voltage and low current (gold flash or similar).

3.3 Control Circuits



WARNING

Isolate the CSX completely from the power supply before attempting any work on the CSX or motor. Control terminals may be at phase voltage potential.



AVERTISSEMENT

Isoler complètement le CSX de l'alimentation secteur avant de tenter toute intervention sur le CSX ou sur le moteur. Les bornes de commande peuvent être au potentiel de la tension de phase.



CAUTION

For CSX-xxx-xx-C2 (24 VAC/VDC control voltage) units you can connect an external 24 VDC supply into the control input terminals 01, 02.

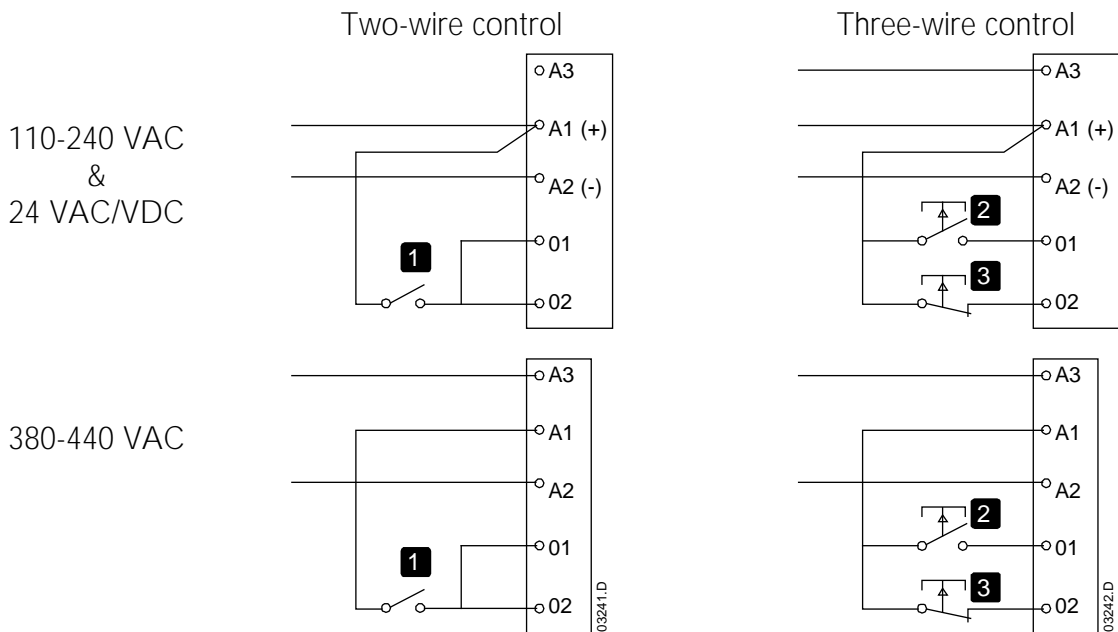

1	Start/stop. To reset a trip, open then close 02.
2	Start.
3	Stop. To reset a trip, open then close 02.

3.4 Outputs

Main Contactor Output

The Main Contactor output (terminals 13, 14) closes as soon as the soft starter receives a start command and remains closed while the soft starter is controlling the motor (until the motor starts a coast to stop, or until the end of a soft stop). The Main Contactor output will also open if the soft starter trips.

The Main Contactor output can be used to directly control a main contactor coil.

Run Contactor Output

The relay (terminals 23, 24) operates four seconds after the set start ramp time is complete. The relay can be used to operate a contactor for power factor correction capacitors, or to signal soft starter run status to an automation system.

3.5 Electrical Schematics

Soft starter installed with a motor protection circuit breaker

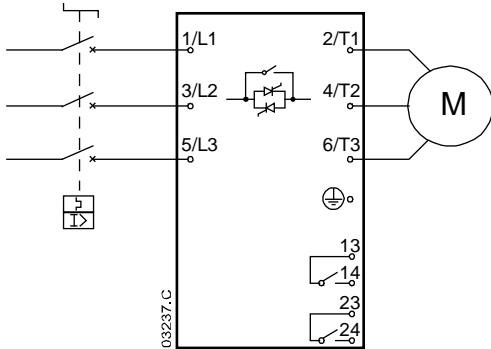

Soft starter installed with a motor protection circuit breaker and main contactor

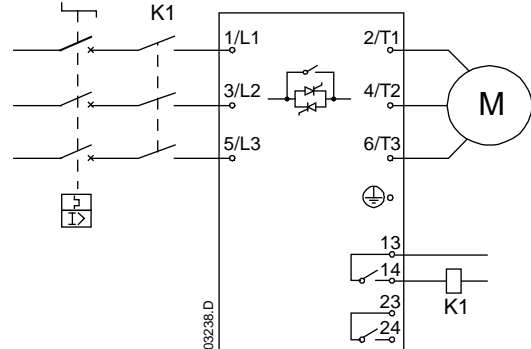

M	Motor (three phase)
K1	Main contactor
13, 14	Main contactor output
23, 24	Run contactor output

4. Adjustments

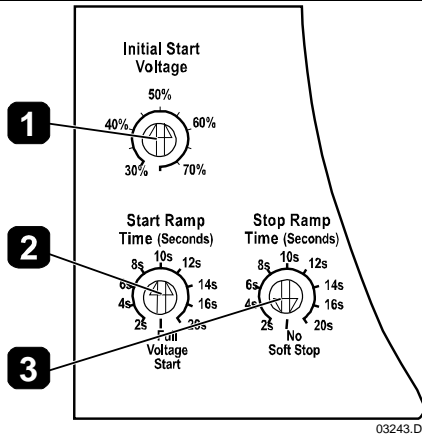

- 1** Initial Start Voltage
- 2** Start Ramp Time
- 3** Stop Ramp Time

1 Initial Start Voltage

Select the initial start voltage (A).

Application	Initial Start Voltage - Suggested setting
Centrifugal Pump	50%
Submersible Pump	60%
Screw Compressor	
Conveyor	70%
Crusher	
Fan	
Other applications	

2 Start Ramp Time

Select the start ramp time (B).

The start ramp defines how long the soft starter will take to increase voltage from the initial start voltage to full voltage.

The start ramp time does not control the time the motor will take to reach full speed.

1. Set the start ramp time to 20 seconds.
2. Set the initial start voltage as required for the application.
3. Attach a current monitoring device to output T1.
4. Start the motor under normal load conditions. Record the time required for the measured current to fall to (or below) the motor's rated full load current (t_1) then stop the motor.
5. Set start ramp time = t_1 .

NOTE

The start ramp time must be long enough for the motor to reach full speed before the soft starter enters bypass mode.

3 Stop Ramp Time

Select the soft stop ramp time (C).

Soft stop extends the time soft starter takes to reduce voltage to zero.

The ramp time does not control the time the motor will take to stop completely.

5. Troubleshooting

5.1 LEDs

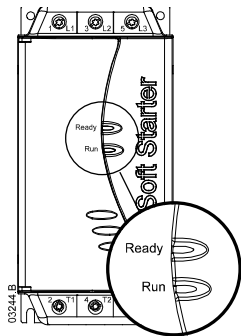

LED Status	Ready	Run
Off	No control power	Motor not running
On	Ready	Motor running at full speed
Flash	Starter tripped	Motor starting or stopping

5.2 Trip Codes

The Ready LED will flash a different number of times to indicate the cause of the trip.

Ready LED	Description
☀ x 1	Power Circuit: Check mains supply (L1, L2, L3), motor circuit (T1, T2, T3), soft starter SCRs and bypass relays.
☀ x 6	Supply Frequency: Check mains voltage is available and supply frequency is in range.
☀ x 8	Network Communication Failure (between module and network): Check network connections, settings and configuration.
☀ x 9	Starter Communication Failure (between starter and module): Remove and refit accessory module.

Supply Frequency Protection

The soft starter will trip on supply frequency if the frequency rises above 72 Hz or falls below 40 Hz for more than five seconds while the soft starter is running. These trip points are not adjustable.

In pre-start, starting and stopping modes the high and low frequency limits both apply with no time delay.

A supply frequency trip will also occur if:

- all three input phases are lost while the soft starter is running
- all three input phases fall below 120 VAC at start or while the soft starter is running
- the line contactor opens while running

5.3 Reset

Trips can be cleared by pressing the Reset button on the soft starter, sending a Reset command from the serial communications network, or by switching the control inputs.

To clear a trip via the control inputs, the soft starter requires a closed to open transition on the stop input (O2).

- In three-wire control, use the external stop button to momentarily open the stop input (open A1-O2).
- In two-wire control, if the soft starter tripped with a start signal present, remove the start signal (open A1 to O1, O2).

The Reset button is located on the front of the unit, above the adjustment switches.

The soft starter will trip again immediately if the cause of the trip still exists.

6. Accessories

6.1 Finger Guard Kit

Finger guards may be specified for personnel safety. Finger guards fit over the soft starter terminals to prevent accidental contact with live terminals. Finger guards provide IP20 protection when used with cable of diameter 22 mm or greater.

6.2 Remote Operator

The Remote Operator can control and monitor the soft starter's performance. Functionality includes:

- Operational control (Start, Stop, Reset, Quick Stop)
- Starter status monitoring (Ready, Starting, Running, Stopping, Tripped)
- Trip code display

6.3 Communication Interfaces

CSX soft starters support network communication via easy-to-install communications interfaces. Each soft starter can support one communications interface at a time.

Available protocols:

Ethernet (Profinet, Modbus TCP, Ethernet/IP), Profibus, DeviceNet, Modbus RTU, and USB.

6.4 PC Software

WinMaster can be used with AuCom soft starters to provide the following functionality for networks of up to 99 soft starters:

- Operational control (Start, Stop, Reset, Quick Stop)
- Starter status monitoring (Ready, Starting, Running, Stopping, Tripped)

To use WinMaster with the CSX, the soft starter must be fitted with a USB Module, Modbus Module or a Remote Operator.

7. Specifications

7.1 Model Code

CSX - - -

Control voltage

C1 = 110-240 VAC & 380-440 VAC

C2 = 24 VAC/VDC

Mains voltage

V4 = 200 ~ 440 VAC

V6 = 200 ~ 575 VAC

Nominal kW rating @400 VAC

≤ 30 kW AC53b 4-6-354

≥ 37 kW AC53b 4-6-594

Motor protection

Blank = Without motor protection

i = With motor protection

7.2 Current Ratings

	AC53b 4-6:354 < 1000 metres		AC53b 4-20:340 < 1000 metres	
	40 °C	50 °C	40 °C	50 °C
	CSX-007	18 A	17 A	17 A
CSX-015	34 A	32 A	30 A	28 A
CSX-018	42 A	40 A	36 A	33 A
CSX-022	48 A	44 A	40 A	36 A
CSX-030	60 A	55 A	49 A	45 A
	AC53b 4-6:594 < 1000 metres		AC53b 4-20:580 < 1000 metres	
	40 °C	50 °C	40 °C	50 °C
	CSX-037	75 A	68 A	65 A
CSX-045	85 A	78 A	73 A	67 A
CSX-055	100 A	100 A	96 A	87 A
CSX-075	140 A	133 A	120 A	110 A
CSX-090	170 A	157 A	142 A	130 A
CSX-110	200 A	186 A	165 A	152 A

7.3 Semiconductor Fuses

Semiconductor fuses can be used with CSX soft starters to reduce the potential for damage to SCRs from transient overload currents and for Type 2 coordination. CSX soft starters have been tested to achieve Type 2 coordination with semiconductor fuses. Suitable Bussmann and Ferraz/Mersen semiconductor fuses are detailed below.

Model	SCR I ² t (A ² s)	Ferraz/Mersen Fuse European/IEC Style (North American Style)	Bussmann Fuse Square Body (170M)	Bussmann Fuse British Style (BS88)
CSX-007	1150	6.6URD30xxxA0063 (A070URD30xxx0063)	170M-1314	63 FE
CSX-015	8000	6.6URD30xxxA0125 (A070URD30xxx0125)	170M-1317	160 FEE
CSX-018	10500	6.6URD30xxxA0160 (A070URD30xxx0160)	170M-1318	160 FEE
CSX-022	15000	6.6URD30xxxA0160 (A070URD30xxx0160)	170M-1318	180 FM
CSX-030	18000	6.6URD30xxxA0160 (A070URD30xxx0160)	170M-1319	180 FM
CSX-037	51200	6.6URD30xxxA0250 (A070URD30xxx0250)	170M-1321	250 FM
CSX-045	80000	6.6URD30xxxA0315 (A070URD30xxx0315)	170M-1321	250 FM
CSX-055	97000	6.6URD30xxxA0315 (A070URD30xxx0315)	170M-1321	250 FM
CSX-075	168000	6.6URD31xxxA0450 (A070URD31xxx0450)	170M-1322	500 FMM
CSX-090	245000	6.6URD31xxxA0450 (A070URD31xxx0450)	170M-3022	500 FMM
CSX-110	320000	6.6URD31xxxA0450 (A070URD31xxx0450)	170M-3022	500 FMM

xxx = Blade Type. Contact Ferraz/Mersen for options.

7.4 General Technical Data

Mains Supply

Mains voltage (L1, L2, L3)

V4 3 x 200 VAC ~ 440 VAC (+ 10% / - 15%)

V6 3 x 200 VAC ~ 575 VAC (+ 10% / - 15%)

Mains frequency (at start) 45 Hz to 66 Hz

Rated insulation voltage 600 VAC

Form designation Bypassed semiconductor motor starter form 1

Control Voltage (A1, A2, A3)

CSX-xxx-xx-C1 110-240 VAC (+ 10% / - 15%)
 or 380-440 VAC (+ 10% / - 15%)

CSX-xxx-xx-C2 24 VAC/VDC (± 20%)

Current consumption (during run) < 100 mA

Current consumption (inrush)

CSX-xxx-xx-C1 10 A

CSX-xxx-xx-C2 2 A

Inputs

Start (terminal 01) Normally open
 150 kW @ 300 VAC and 5.6 kW @ 24 VAC/VDC

Stop (terminal 02) Normally closed
 150 kW @ 300 VAC and 5.6 kW @ 24 VAC/VDC

SPECIFICATIONS

Outputs

Main contactor (terminals 13, 14)	Normally open 6 A, 30 VDC / 6 A, 250 VAC resistive
Run relay (terminals 23, 24)	Normally open 6 A, 30 VDC / 6 A, 250 VAC resistive

Environmental

Degree of Protection CSX-007 to CSX-055	IP20
Degree of Protection CSX-075 to CSX-110	IP00
Operating temperature	-10 °C to +60 °C
Storage temperature	-25 °C to +60 °C (to +70 °C for less than 24 hours)
Humidity	5% to 95% Relative Humidity
Pollution degree	Pollution Degree 3
Vibration	IEC 60068 Test Fc Sinusoidal 4 Hz to 13.2 Hz: ± 1 mm displacement 13.2 Hz to 200 Hz: ± 0.7 g

EMC Emission

Equipment class (EMC)	Class B
Conducted radio frequency emission	0.15 MHz to 0.5 MHz: < 56-46 dB (µV) 0.5 MHz to 5 MHz: < 46 dB (µV) 5 MHz to 30 MHz: < 50 dB (µV)
Radiated radio frequency emission	30 MHz to 230 MHz: < 30 dB (µV/m) 230 MHz to 1000 MHz: < 37 dB (µV/m)

EMC Immunity

Electrostatic discharge	4 kV contact discharge, 8 kV air discharge
Radio frequency electromagnetic field	0.15 MHz to 1000 MHz: 140 dB (µV)
Rated impulse withstand voltage (Fast transients 5/50 ns)	2 kV line to earth, 1 kV line to line
Voltage dip and short time interruption	100 ms (at 40% nominal voltage)
Harmonics and distortion	IEC61000-2-4 (Class 3), EN/IEC61800-3

Short Circuit

Rated short-circuit current CSX-007 to CSX-022	5 kA ¹
Rated short-circuit current CSX-030 to CSX-110	10 kA ¹

¹ These short circuit ratings are with fuses used as given in the table under *Semiconductor Fuses* on page 10.

Heat Dissipation

During Start	3 watts / ampere
During Run	10 watts typical

Standards Approvals

CÜ	IEC 60947-4-2
CE	IEC 60947-4-2
CCC	GB 14048.6
EAC	TP TC 004/2011, TP TC 020/2011
Marine	Lloyds Marine No 1 Specification
UL / C-UL	UL 508

Operational Life

CSX-007~055	1,000,000 operations
CSX-075~110	30,000 operations





CSX

Soft Starter

AuCom
THE SOFT START SPECIALISTS

SERVICE MANUAL

Contents

Section 1	Caution Statements	2
1.1	Safety Regulations.....	2
Section 2	Troubleshooting.....	3
2.1	Functional Tests.....	3
2.2	Fault Diagnosis.....	4
Section 3	Avoiding Damage.....	7
3.1	SCRs.....	7
3.2	Output Relays.....	7
3.3	Control Inputs.....	8
Section 4	Service Instructions.....	9
4.1	Exploded View CSX-007~CSX-030.....	9
4.2	Exploded View CSX-037~CSX-055.....	9
4.3	Exploded View CSX-075~CSX-110.....	10
4.4	Exploded View CSXi-007~CSXi-030.....	11
4.5	Exploded View CSXi-037~CSXi-055.....	11
4.6	Exploded View CSXi-075~CSXi-110.....	12
Section 5	Spare Parts.....	13
5.1	CSX.....	13
5.2	CSXi	15
5.3	Finding the Batch Number	17
5.4	SCR Connections	17
Section 6	Disposal Instructions.....	19

Section I Caution Statements**WARNING - ELECTRICAL SHOCK HAZARD**

CSX Series soft starters contain dangerous voltages when connected to mains voltage. Only a competent electrician should carry out the electrical installation. Improper installation of the motor or the soft starter may cause equipment failure, serious injury or death. Follow this manual and local electrical safety codes.

I.1 Safety Regulations

Disconnect the soft starter from mains voltage before carrying out repair work.

Stopping the soft starter does not disconnect the equipment from mains voltage and leaves one phase connected to the motor. The soft starter should **not** be used as a safety switch.

**NOTE**

It is the responsibility of the user or person installing the soft starter to provide proper grounding and branch circuit protection according to local electrical safety codes.

**NOTE**

Many electronic components are sensitive to static electricity. Voltages so low that they cannot be felt, seen or heard, can reduce the life, affect performance, or completely destroy sensitive electronic components. When performing service, proper ESD equipment should be used to prevent possible damage from occurring.

**NOTE**

The CSX Series soft starter is not user serviceable. The unit should only be serviced by authorised service personnel. Unauthorised tampering with the unit will void the product warranty.

© 2003-2008 AuCom Electronics Ltd. All Rights Reserved.

As AuCom is continuously improving its products it reserves the right to modify or change the specification of its products at any time without notice. The text, diagrams, images and any other literary or artistic works appearing in this document are protected by copyright. Users may copy some of the material for their personal reference but may not copy or use material for any other purpose without the prior consent of AuCom Electronics Ltd. AuCom endeavours to ensure that the information contained in this document including images is correct but does not accept any liability for error, omission or differences with the finished product.

Section 2 Troubleshooting

2.1 Functional Tests

Use the tests in this section to identify the cause of problems with the soft starter.

Basic Functionality Test

This procedure tests that the soft starter is receiving control voltage.

1. Remove all external wiring from the soft starter control inputs (O1, O2).
2. Connect the soft starter to control voltage (A1-A2 or A2-A3).
 - The Ready LED should come on. If it does not, the Main Control PCB is damaged.

Power Circuit Test

This procedure tests the soft starter's power circuit, including the SCRs, Interface PCB and Main Control PCB.

1. Disconnect the soft starter from mains voltage (L1, L2, L3), control voltage (A1, A2, A3) and from the motor (T1, T2, T3).
2. Use a 500 VDC insulation tester to measure the resistance across L1-T1, L3-T3, T1-L1 and T3-L3. The resistance should be between 30 k Ω and 500 k Ω and equal for all measurements.
 - If the resistance is below 30 k Ω for any measurement, the SCR or bypass relay on that phase has been damaged and must be replaced.
 - If the resistance is above 500 k Ω for any measurement, the Main Control PCB or Interface PCB may be faulty or there may be a faulty connection between these two PCBs. To isolate the fault, perform the PCB integrity test.

CSX Start Performance Test

This procedure tests that the CSX soft starts correctly.

1. Connect the CSX to mains voltage and to a motor.
2. Measure the voltage across L1-T1 and L3-T3. This should be close to the nominal mains voltage.
 - If the voltage is zero, the SCR or bypass relay on that phase may have failed.
3. Command the CSX to start. While the CSX is starting, measure the voltage across L1-T1 and L3-T3. The voltage should fall to less than 2 VAC just before the CSX reaches Run mode.
 - If the voltage remains near nominal mains voltage, the SCR is not firing correctly. This can be caused by a faulty Main Control PCB, a faulty Interface PCB, or a poor connection between these two PCBs. To isolate the fault, perform the PCB integrity test.

CSXi Start Performance Test

This procedure tests that the CSXi soft starts correctly.

1. Calculate the expected motor start current by multiplying the CSXi current rating by the Motor FLC setting and the Current Limit setting.
2. Connect the CSXi to mains voltage and to a motor.
3. Command the CSXi to start. While the CSXi is starting, measure the current on L1 and L3.
 - If the current does not stabilise at expected level, the SCR is not firing correctly. This can be caused by a faulty Main Control PCB, a faulty Interface PCB, or a poor connection between these two PCBs. To isolate the fault, perform the PCB integrity test.

Bypass Relay Test

CSX Series soft starters incorporate internal bypass relays. This procedure tests the operation of the internal bypass relays.

1. Connect the soft starter to mains voltage and to a motor.
2. Measure the voltage across L1-T1 and L3-T3. This should be close to the nominal mains voltage.
 - If the voltage is zero, the SCR or bypass relay on that phase may have failed.
3. Command the soft starter to start. When the Run LED stops flashing you should hear the bypass relay close.

- If the bypass relay does not close, the bypass relay, Main Control PCB or Interface PCB may be faulty, or there may be a faulty connection between these components. To isolate the fault, perform the bypass relay integrity test.
4. When the soft starter is running, measure the voltage across LI-T1 and L3-T3. This should be less than 0.5 VAC.
 - If the voltage remains near nominal mains voltage, the bypass relay did not close. This can be caused by a faulty relay, faulty Main Control PCB, a faulty Interface PCB, or a poor connection between these two PCBs. To isolate the fault, perform the bypass relay integrity test.
 5. Command the soft starter to stop. You should hear the bypass relay open.
 - If the bypass relay does not open, perform the bypass relay integrity test.

2.2 Fault Diagnosis

PCB Integrity Test

This procedure further isolates a fault with the soft starter's control circuitry.

1. Verify that the connection between the Main Control PCB and the Interface PCB is sound.
 - remove and refit the Main Control PCB
 - check whether the soft starter now operates correctly
2. Verify that the Main Control PCB is sound.
 - remove and replace the Main Control PCB
 - check whether the soft starter now operates correctly
3. Verify that the Interface PCB is sound.
 - refit the original Main Control PCB
 - remove and replace the Interface PCB
 - check whether the soft starter now operates correctly

If the fault cannot be traced to either the Main Control PCB or the Interface PCB, replace both PCBs.

Bypass Relay Integrity Test

This procedure further isolates a fault with the soft starter's bypass circuitry.

1. Verify that the connections between the Main Control PCB and the Interface PCB, and between the Interface PCB and the bypass relay are sound.
 - remove the Main Control PCB
 - remove the Interface PCB
 - refit the Interface PCB to the bypass relays
 - refit the Main Control PCB
 - check whether the soft starter now operates correctly
2. Verify that the bypass relay is sound.
 - remove the Main Control PCB and Interface PCB
 - momentarily apply 24 VDC to the bypass relay control pins. The bypass relay should change state. The bypass relays are latching, so behaviour must be checked by applying voltage in both directions.

If the bypass relay does not change state correctly, it must be replaced.

Figure 1: Bypass relay control pins (7 kW ~ 30 kW models)

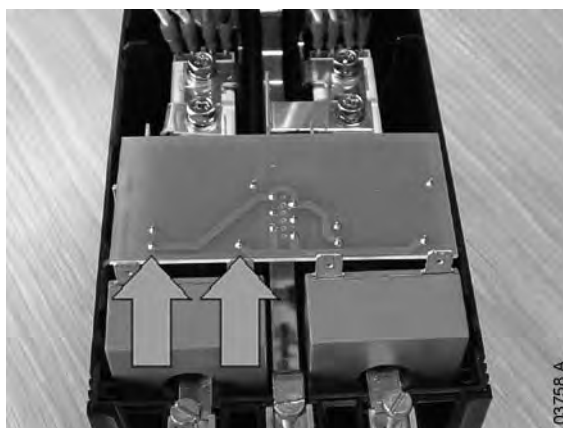

Figure 2: Bypass relay control pins (37 kW ~ 55 kW models)

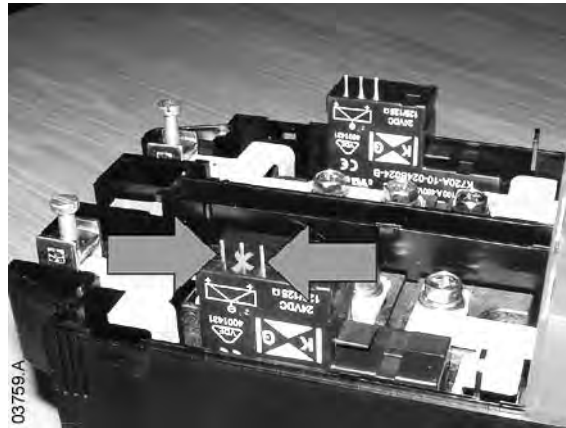

Figure 3: Bypass relay control wires (75 kW ~ 110 kW models)



PCB Visual Inspection

Damage to the MOV on the Main Control PCB may indicate that incorrect control voltage has been applied to the unit.

Figure 4: Location of MOV on Main Control PCB

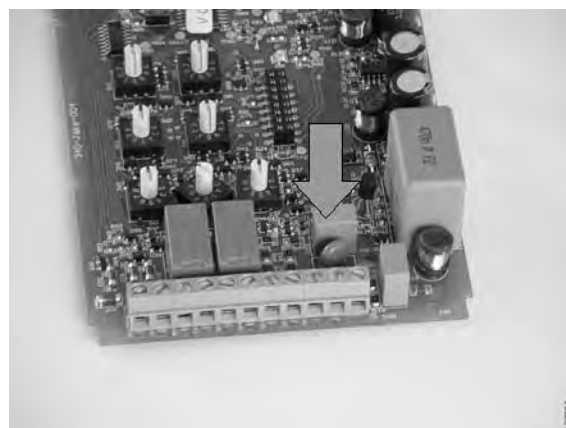

Damage to the MOVs and/or surrounding circuitry on the Interface PCB may indicate that the soft starter has suffered overvoltage. This usually also damages the SCRs.

Figure 5: MOV location on Interface PCB (7 kW ~ 30 kW models)

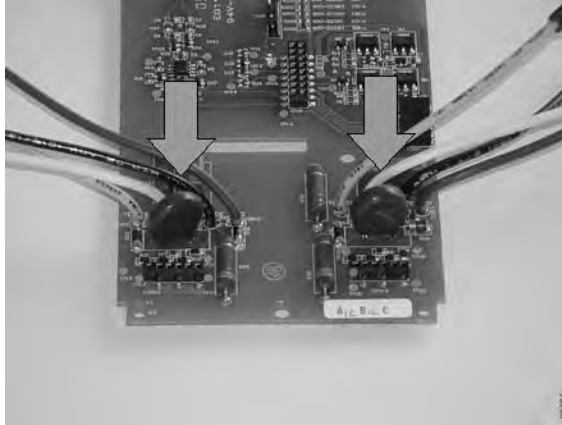

Figure 6: MOV location on Interface PCB (37 kW ~ 55 kW models)

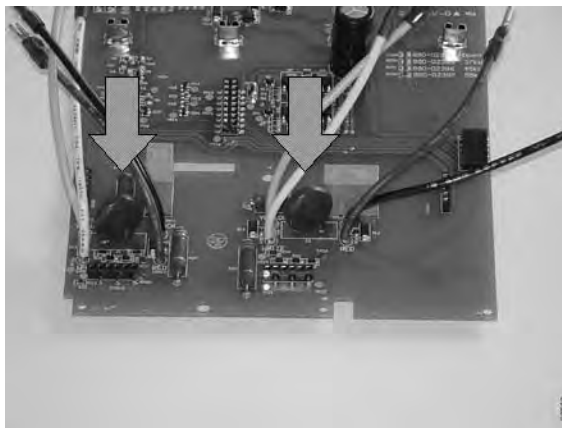
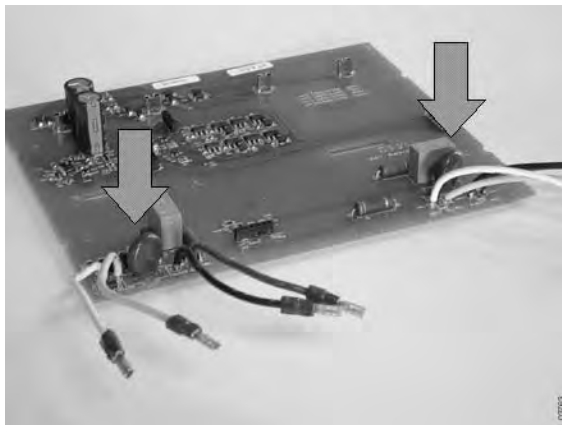

Figure 7: MOV location on Interface PCB (75 kW ~ 110 kW models)



Section 3 Avoiding Damage

3.1 SCRs

SCR damage is generally caused by overcurrent, overvoltage or overtemperature. To prevent future damage, check that the soft starter has been installed properly. Common causes of SCR problems include:

Overcurrent:

- cable fault on soft starter output
- motor fault
- start current and/or start time exceeds the soft starter's rating
- starts per hour exceed the soft starter rating

Overvoltage:

- power supply transient or surge
- lightning strike (direct or indirect) on power supply
- motor fault
- loose connection in power circuit, before or after the starter
- power factor correction connected to the output of the soft starter
- over-corrected bulk power factor correction on a lightly loaded system causing severe ringing voltages

Overtemperature:

- blocked heatsinks or restricted ventilation
- inadequate ventilation
- excessive ambient temperatures
- bypass relay fails to close during running

Protecting SCRs

Modern SCRs are generally rugged and reliable. However, the risk of SCR damage can be reduced by using semiconductor fuses and/or a main contactor.

- **Semiconductor Fuses**

Semiconductor fuses reduce the potential for SCR damage caused by short circuits on the output of the starter.

Protection systems such as circuit breakers or HRC fuses do not operate quickly enough to protect SCRs from short circuits.

- **Main Contactors**

SCRs are most vulnerable to overvoltage damage when voltage is applied to their input terminal while they are off. In this condition the SCR is blocking the full line voltage. Using a main contactor to remove voltage from the SCR input when the starter is off eliminates the risk of SCR damage due to overvoltage.

3.2 Output Relays

CSX Series soft starters have one fixed output relay (terminals 13, 14) and CSX/soft starters have one fixed and one programmable output relay (terminals 13, 14 and 23, 24). These relays are often used to control the main contactor.

The electronic contactor coils used in many contactors have a high initial inrush current, which can damage the soft starter's internal relays if the contactor coil is switched directly.

Using the Soft Starter to Switch a Contactor

Before using the soft starter's output relay to switch an electronic contactor coil, consult the contactor manufacturer. Some contactor manufacturers (eg Klockner-Moeller) state that you cannot use PCB mount relays for direct switching of their electronic contactor coils.

If this is the case, there are two solutions:

1. Use the soft starter's output relay to control a slave relay. This slave relay can then be used to directly switch the electronic contactor coil circuit.

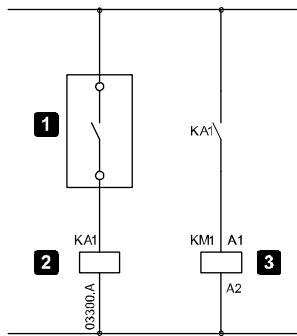

1	Soft starter output relay
2	Slave relay coil
3	Contactor coil

2. If the contactor has a volt free electronic input (low voltage/low current), the soft starter's output relay can be wired directly into this input for contactor control.

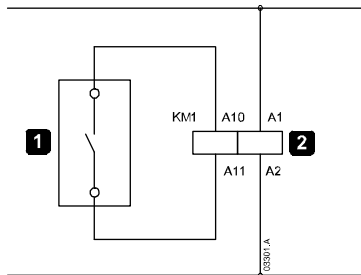

1	Soft starter output relay
2	Contactor coil

3.3 Control Inputs

CSX Series soft starters can be operated by external two wire or three wire control signals. External switches are configured and wired into control input terminals 01, 02.

- External switches operating the control inputs must be rated for the control voltage being used and a continuous current of 100 mA.
- Incorrect configuration and wiring of the external contacts/switches to the control input terminals may cause damage.
- If long cable runs are used, wiring must be twisted pair or shielded cable and must be separated from AC power cables by at least 300 mm.



NOTE

Applying voltage to the control inputs will damage the soft starter. Damage to the control inputs is not covered by warranty.

Section 4 Service Instructions

4.1 Exploded View CSX-007~CSX-030

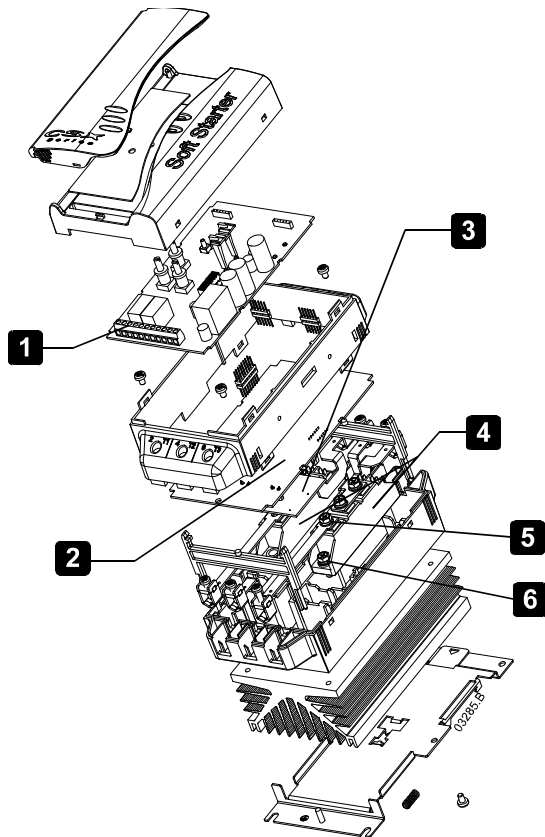

1	Main Control PCB
2	Interface PCB
3	Bypass relays
4	SCRs
5	SCR-bus bar connection (tighten to 4 Nm)
6	SCR-heatsink connection (tighten to 4 Nm)

4.2 Exploded View CSX-037~CSX-055

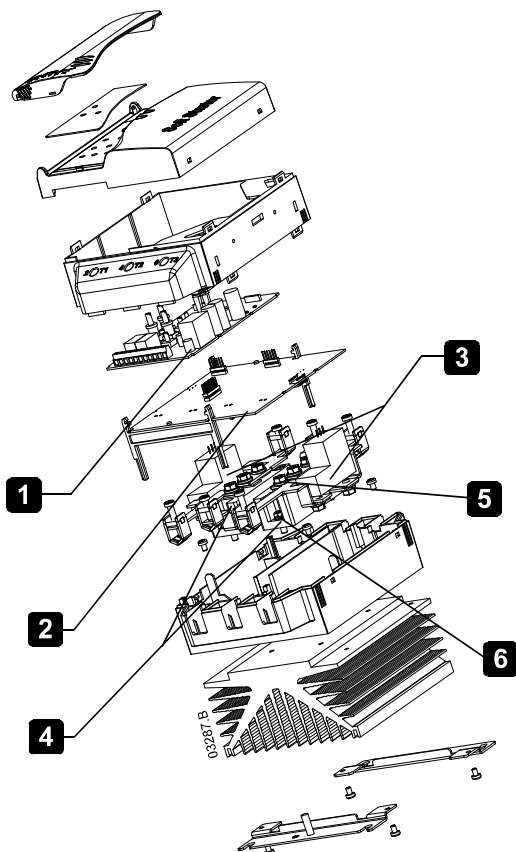

1	Main Control PCB
2	Interface PCB
3	Bypass relays
4	SCRs
5	SCR-bus bar connection (tighten to 5 Nm)
6	SCR-heatsink connection (tighten to 4 Nm)

4.3 Exploded View CSX-075~CSX-110

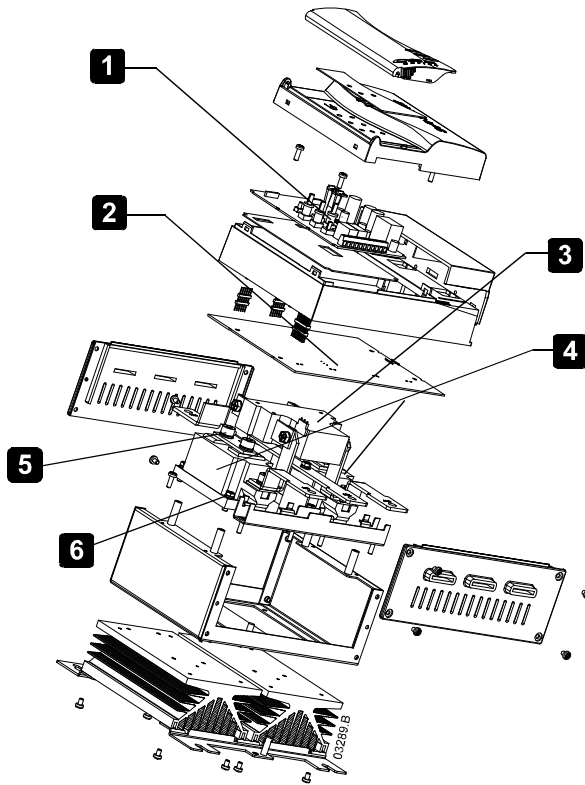

1	Main Control PCB
2	Interface PCB
3	Bypass relays
4	SCRs
5	SCR-bus bar connection (tighten to 9 Nm)
6	SCR-heatsink connection (tighten to 4 Nm)

4.4 Exploded View CSXi-007~CSXi-030

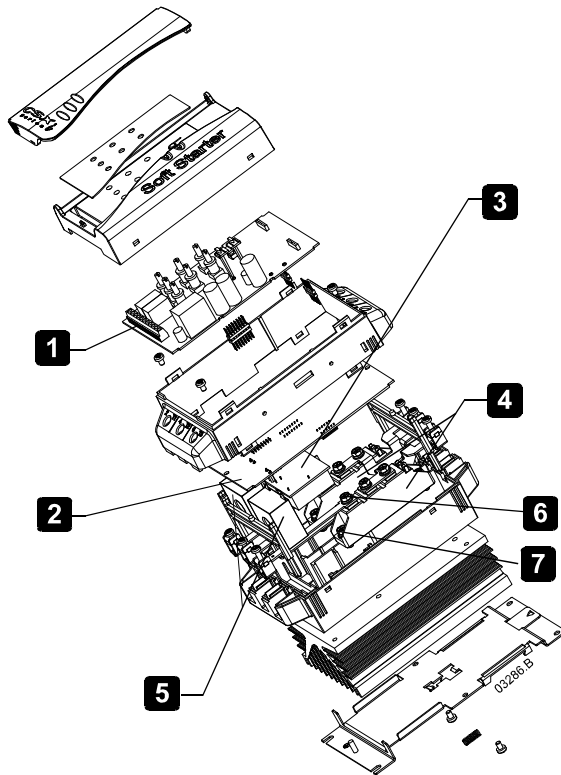

1	Main Control PCB
2	Interface PCB
3	Bypass relays
4	SCRs
5	Current transformers
6	SCR-bus bar connection (tighten to 4 Nm)
7	SCR-heatsink connection (tighten to 4 Nm)

4.5 Exploded View CSXi-037~CSXi-055

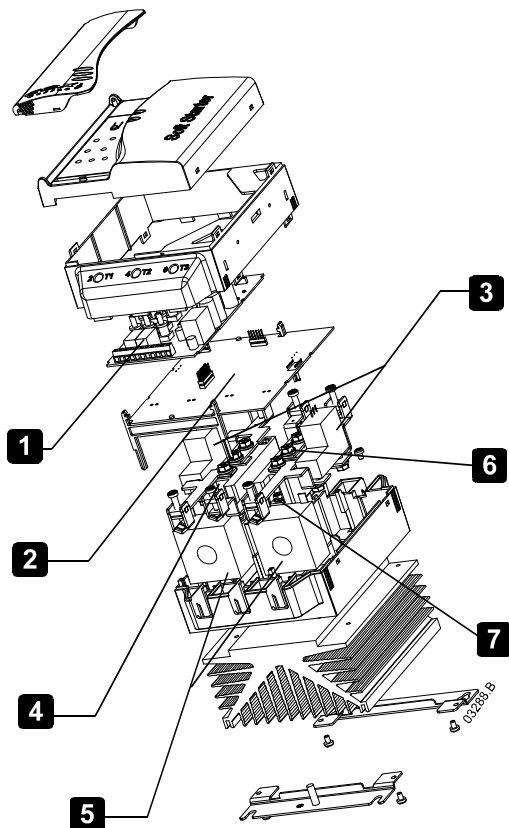

1	Main Control PCB
2	Interface PCB
3	Bypass relays
4	SCRs
5	Current transformers
6	SCR-bus bar connection (tighten to 7 Nm)
7	SCR-heatsink connection (tighten to 4 Nm)

4.6 Exploded View CSXi-075~CSXi-110

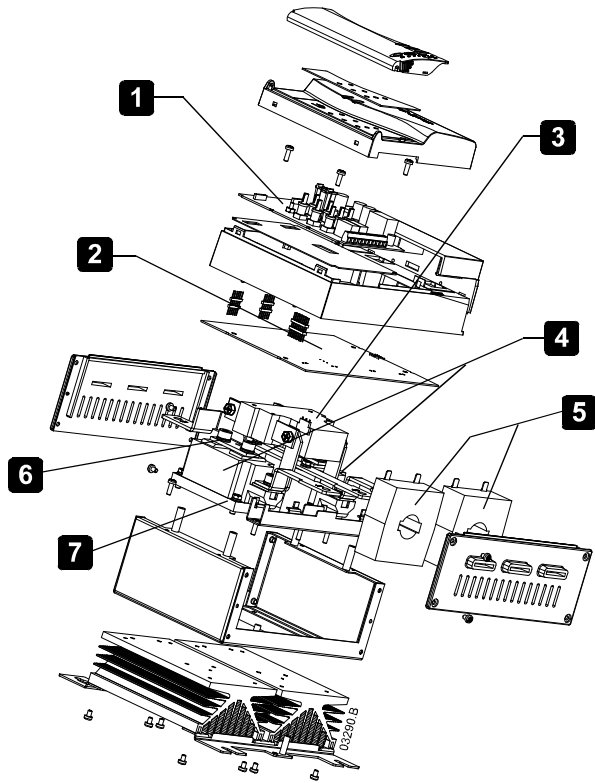

1	Main Control PCB
2	Interface PCB
3	Bypass relays
4	SCRs
5	Current transformers
6	SCR-bus bar connection (tighten to 12 Nm)
7	SCR-heatsink connection (tighten to 4 Nm)

Section 5 Spare Parts



NOTE

The numbers shown indicate the quantity required for each starter. Unless otherwise indicated, spare part kits contain only one of each item.

5.1

CSX

Main Control PCB

Each soft starter requires one Main Control PCB.

	CI Models	C2 Models
CSX-xxx-V4-xx	995-02535-00	995-02536-00
CSX-xxx-V6-xx	995-02539-00	995-02540-00

CSX Interface PCB

Each soft starter requires one Interface PCB.

CSX-007	995-02543-00
CSX-015	
CSX-018	
CSX-022	
CSX-030	
CSX-037	995-04516-00 ¹
CSX-045	
CSX-055	
CSX-075	995-03874-00 ²
CSX-090	
CSX-110	

¹ This part is suitable for use with CSX Series units of version 10 or later (serial number xxxxx-10). Please contact AuCom for assistance with earlier versions.

² This part is suitable for use with CSX Series units of version 7 or later (serial number xxxxx-07). Please contact AuCom for assistance with earlier versions.

SCRs

Each soft starter requires two SCRs.

CSX-007	995-02557-00
CSX-015	995-02558-00
CSX-018	995-02559-00
CSX-022	995-02560-00
CSX-030	995-02561-00
CSX-037	995-02562-00
CSX-045	995-02563-00
CSX-055	995-02564-00
CSX-075	995-02565-00
CSX-090	995-02566-00
CSX-110	995-02567-00

Bypass Relays

Soft starter models 007~030 and 075~110 require one bypass relay per starter. Models 037~055 require two relays per starter.

CSX-007	995-02568-00
CSX-015	
CSX-018	
CSX-022	
CSX-030	
CSX-037	995-04515-00 ¹
CSX-045	
CSX-055	
CSX-075	995-03873-00 ²
CSX-090	
CSX-110	

¹ This kit is suitable for use with CSX Series units of version 10 or later (serial number xxxxx-10, batch number 060227). Please contact AuCom for assistance with earlier versions.

² This kit is suitable for use with CSX Series units of version 7 or later (serial number xxxxx-07, batch number 050602). Please contact AuCom for assistance with earlier versions.

995-02568-00

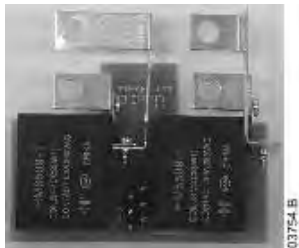

995-04515-00



995-03873-00



5.2 CSXi

Main Control PCB

Each soft starter requires one Main Control PCB.

	CI Models	C2 Models
CSXi-xxx-V4-xx	995-02537-00	995-02538-00
CSXi-xxx-V6-xx	995-02541-00	995-02542-00

CSXi Interface PCB

Each soft starter requires one Interface PCB.

CSXi-007	995-02546-00
CSXi-015	995-02547-00
CSXi-018	995-02548-00
CSXi-022	995-02549-00
CSXi-030	995-02550-00
CSXi-037	995-04517-00 ¹
CSXi-045	995-04518-00 ¹
CSXi-055	995-04519-00 ¹
CSXi-075	995-03875-00 ²
CSXi-090	995-03876-00 ²
CSXi-I 10	995-03877-00 ²

¹ This part is suitable for use with CSX Series units of version 10 or later (serial number xxxxx-10). Please contact AuCom for assistance with earlier versions.

² This part is suitable for use with CSX Series units of version 7 or later (serial number xxxxx-07). Please contact AuCom for assistance with earlier versions.

SCRs

Each soft starter requires two SCRs.

CSXi-007	995-02557-00
CSXi-015	995-02558-00
CSXi-018	995-02559-00
CSXi-022	995-02560-00
CSXi-030	995-02561-00
CSXi-037	995-02562-00
CSXi-045	995-02563-00
CSXi-055	995-02564-00
CSXi-075	995-02565-00
CSXi-090	995-02566-00
CSXi-I 10	995-02567-00

Bypass Relays

Soft starter models 007~030 and 075~I 10 require one bypass relay per starter. Models 037~055 require two relays per starter.

CSXi-007	995-02568-00
CSXi-015	
CSXi-018	
CSXi-022	
CSXi-030	
CSXi-037	995-04515-00 ¹
CSXi-045	
CSXi-055	
CSXi-075	995-03873-00 ²
CSXi-090	
CSXi-I 10	

SPARE PARTS

¹ This kit is suitable for use with CSX Series units of version 10 or later (serial number xxxxx-10, batch number 060227). Please contact AuCom for assistance with earlier versions.

² This kit is suitable for use with CSX Series units of version 7 or later (serial number xxxxx-07, batch number 050602). Please contact AuCom for assistance with earlier versions.

995-02568-00

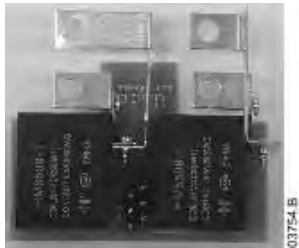

995-04515-00



995-03873-00



CSXi Current Transformers

Each soft starter requires two current transformers.

CSX-007	995-02571-00
CSX-015	
CSX-018	
CSX-022	
CSX-030	
CSX-037	995-02572-00
CSX-045	
CSX-055	
CSX-075	995-02573-00
CSX-090	
CSX-110	

995-02571-00
995-02572-00
995-02573-00

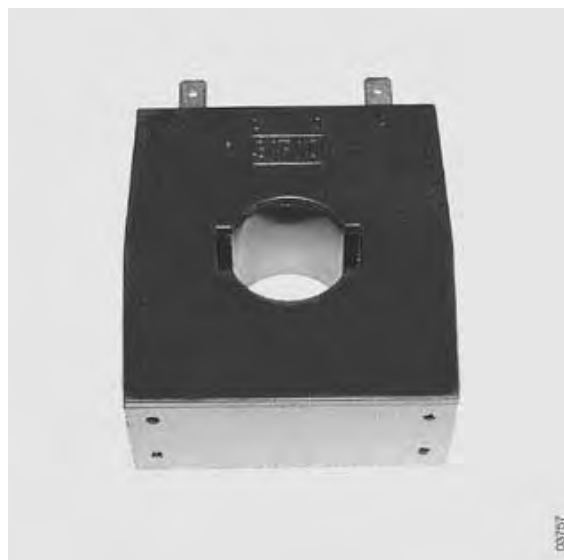

5.3 Finding the Batch Number

The soft starter's batch number can be identified from a label on each PCB.

For boards with a barcode, the batch number is on the barcode label.

For boards with no barcode, the batch number is a six digit number on a separate label.

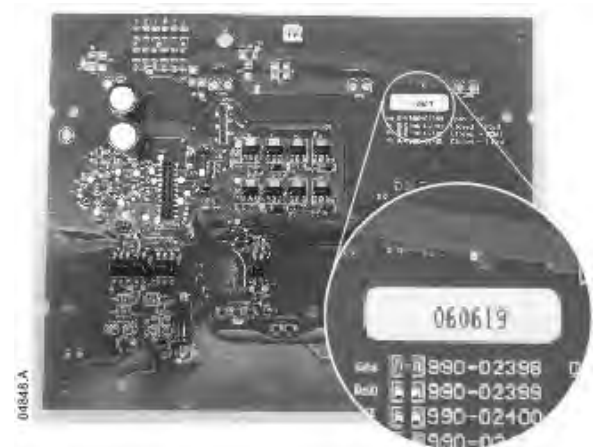
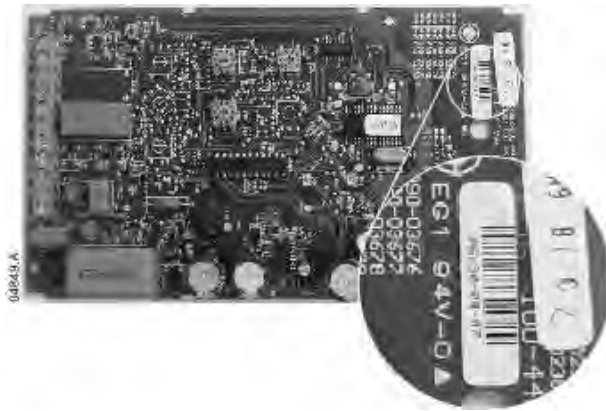

5.4 SCR Connections



NOTE

Spare part kits may include either Semikron or Eupec SCRs. These SCRs are fully interchangeable in CSX Series units and can be mixed within the same soft starter.

The connections between the Interface PCB and SCR depend on the revision of the Interface PCB (340-02471-00x, 340-02472-00x, 340-02473-00x). Connect the firing looms according to the diagrams below:

- 995-02557-00
- 995-02558-00
- 995-02559-00
- 995-02560-00
- 995-02561-00



PCB revision -00C

PCB revision -00D or later

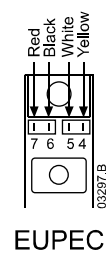
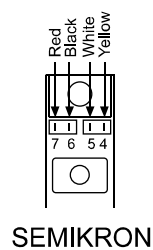
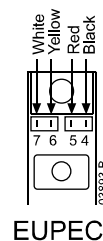
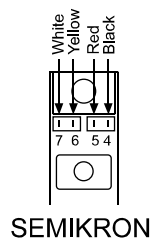

SPARE PARTS

995-02562-00
 995-02563-00
 995-02564-00

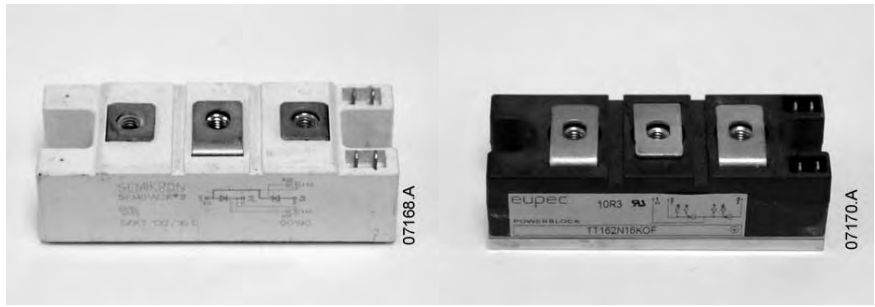

PCB revision -00C

PCB revision -00D or later

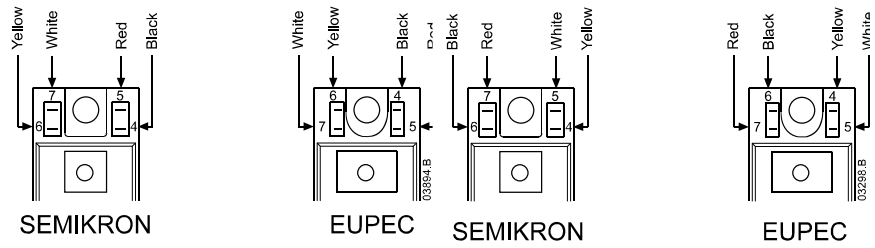

995-02565-00
 995-02566-00
 995-02567-00

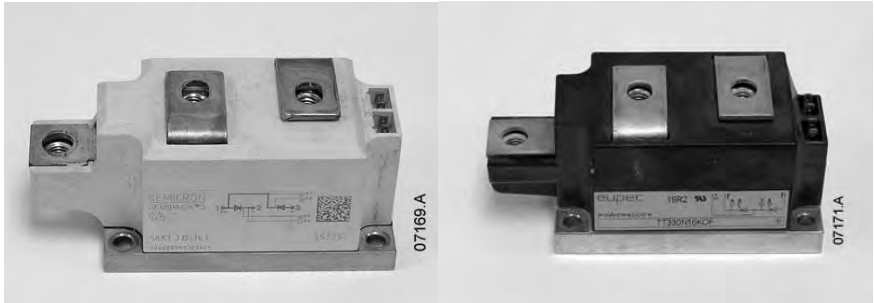

PCB revision -00C

PCB revision -00D or later

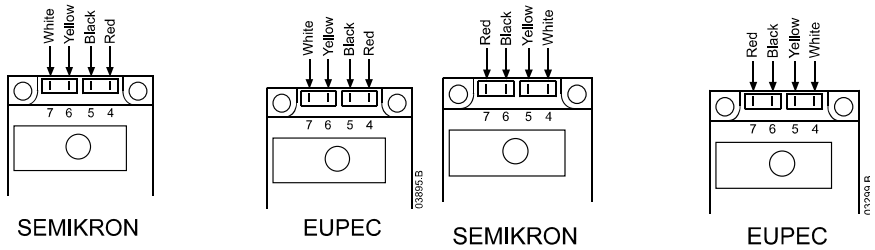

Section 6 Disposal Instructions

Component/Fraction	Environmental conditions	Dismantling/Scrapping	Characteristics
Aluminium	No problems	Re-melt.	Separate from the rest to secure high grade of recovery.
Steel	No problems	Re-melt.	Separate from the rest to secure high grade of recovery.
Wires	No problems	Re-melt in copper works with previous shredding if necessary. PVC must be incinerated at high temperature followed by rapid cooling.	The isolation contains softeners, gloves are recommended. Some of the isolation is made of PVC.
Printed circuit boards Current transformers SCRs	Problems	Copper recycling facilities, where all precious metals are recovered and heavy metals and other hazardous substances are bounded in the remainder fraction.	All printed circuit boards and components with plastics contain flame retardant. The tin solder contains lead.
Plastics	Problems	Controlled incineration or recycling	Plastics are polycarbonate or polycarbonate/ABS alloy and contain glass and flame retardant.

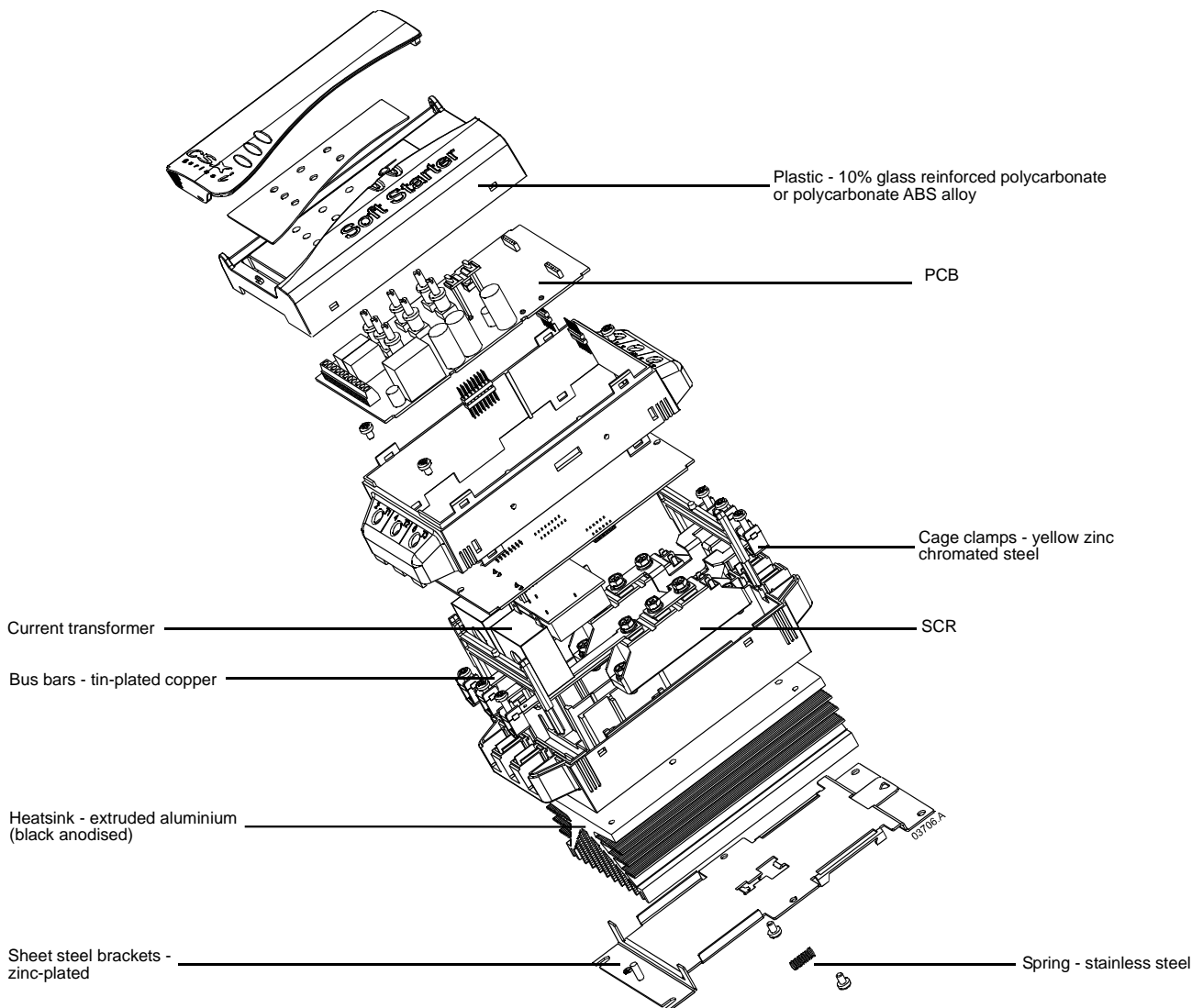

AuCom

AuCom Electronics Ltd
123 Wrights Road
PO Box 80208
Christchurch 8440
New Zealand
T +64 3 338 8280
F +64 3 338 8104
E enquiry@aucom.com
W www.aucom.com