

KAMITECH SRL
Via G. di Vittorio, 6
50023 Impruneta (FI)
PI. 07082600482

www.kamitechsrl.com
info@kamitechsrl.com
TEL. 0557967752
Mob. 3293314270

* 鋒樺科技伺服精密減速器產品 *

Fenghua Technology Servo Precision Reducer Products



行星式減速機
Planetary Gearbox

RV減速器
RV Reducer

90度直角減速機
90 Degree Right Angle Gearbox



鋒樺傳動致力為您提供精品
專業研發生產各類精密行星齒輪傳動系列產品
免費服務熱線：400-8040-668
產品CAD、3D、2D尺寸下載請點擊
www.3fgearmotor.com www.fht.tw



鋒樺傳動科技(江蘇)有限公司
Fenghua Transmission Technology (Jiangsu) Co.,Ltd.

地址：江蘇省昆山市開發區景王路958號
電話：0512-50167005 / 18051125303
郵箱：sales@3fgearmotor.com
網址：www.3fgearmotor.com
國際銷售部 Overseas sales department
+86-180 1932 2748 (whatsapp / wechat / skype)
Email:sales@3fgearbox.com Https://www.3fgearbox.com

运营中心 Operation center

鋒樺傳動設備(上海)有限公司

地址：上海市嘉定區嘉鬆北路敏楓工業區4777號
電話：021-39948832 / 39948836 13701956498
免費服務熱線：400-8040-668
傳真：021-3994 8836
企業官方QQ: 4008040668
郵箱：fht@fht.tw 網址：www.fht.tw

天津辦事處/Tian jin

地址：天津市南開區密雲路五金城2區
6棟118增1號
電話：022-87809695
傳真：022-87809695
手機：15620987332

美國加拿大/USA /Canada

2658 Industrial Blvd.
Bethel Park, PA 15689-2255, USA
phone : (+1) 412/8356556
fax : (+1) 412/8356558
E-mail : fht@fht-usa.com

浙江辦事處/ Zhe jiang

地址：浙江省杭州市拱墅區康橋路75號
中青大廈413室
電話：0571-86699905
傳真：0571-86699905

日本/ Japan

西東京營業所：〒183-0005
東京都府中市若松町6丁目2番3号
phone : (042) 402-1368
fax : (042) 402-1369
E-mail: fht@fht-japan.co.jp

福建辦事處/ Fu jian

地址：福建省廈門市集美北部工業區
天英一裏50號
電話：0592-6066458
傳真：0592-6066423

韓國/ Korea

5-6606, Ace Hitech City
58-16 Mullae-Dong 2-Ga,
Youngdeungpo-Ku, Seoul, Korea,
phone:(+82) 2-3569-2255
fax: (+82) 2-3569-2266
E-mail : fht@fht-korea.com

台灣鋒樺科技有限公司

台灣地址：臺北市大安區忠孝東路4段
電話：04-2568 6956 / 25686908
網址：www.fht.tw 郵箱：fht@fht.tw

廣東辦事處/ Guang Dong

地址：廣東省東莞市長安鎮振安東路158號
電話：0755-23344659 傳真：0755-23342973
手機：18928431587/18928431697/180 3814 4705

華北辦事處/ North China

地址：濟南市歷下區花園東路力高國際3號樓1單元2004室
電話：0531-86956362 傳真：0531-86956362
手機：15689738188

鋒樺

鋒樺傳動科技(江蘇)有限公司

鋒樺傳動設備(上海)有限公司

台灣鋒樺科技



步進/伺服馬達驅動(機器人行業專配) Stepper/servo motor driving (for robot industry)

諧波減速器 Harmonic Reducer

高性價比-尺寸完全匹配替換日本諧波減速器
High cost-effective/perfectly match and replace the sizes of Japanes harmonic reducers



鋒樺傳動科技(江蘇)有限公司
鋒樺傳動設備(上海)有限公司
台灣鋒樺科技

Fenghua Transmission Technology (Jiangsu) Co.,Ltd.

江苏锋桦传动科技有限公司，由專業制造齒輪工廠開始發展，工廠同仁及研發團隊具有二十幾年齒輪制造研發及設計經驗，工廠早期和台湾技术团队合作，成立精密減速器事業部，研發行星齒輪減速機系列產品設計及制造工藝，後期與日本NDK公司技術團隊合作，研發生產多關節機器人行業減速器(RV高精密擺線針輪減速器)和美國天才發明家C. W. Musser創造發明的波動齒輪裝置(諧波減速器)產品。

諧波減速器是由波發生器柔輪鋼輪三大組件構成，產品利用金屬繞曲變形的傳動方式，通過對齒形啮合及材料和加工精度突破，成功開發CSG.CSF.SHG.SHF.SHD系列諧波減速器產品，廣泛SCARA水平多關節機器人等水平往復關節運動場合。

RV高精密擺線針輪減速器是由擺線針輪和行星支架組成，以其體積小，抗衝擊力強，扭矩大，定位精度高，振動小，減速比大等諸多優點，RV-E, RV-C系類初期廣泛運用於六軸工業機器人，和碼垛機器人，以及焊接領域的焊接機器人，變位機，衝壓領域的衝壓機器人等機器人領域，結合周邊自動化的運用衍生RV-EM, RV-CM, FHA, FHD系列直連電機款型，更方便客戶的選用實施。

鋒樺精密減速器可直接替換德國和日本生產產品，產品系列全部齊全，尺寸精度和日系，德系等廠家減速器完全匹配，產品廣泛運用六軸工業機器人，SCARA水平多關節機器人，并聯機器人，和碼垛機器人，以及焊接領域的焊接機器人，變位機，衝壓領域的衝壓機器人等機器人領域，還有在機床行業的第四和第五軸的旋轉應用，3C和半導體和高端醫療器械領域的旋轉定位控制，和光伏設備，鋰電池等新能源設備領域等都有鋒樺諧波減速器的長期運用！

工廠早期就在中國大陸設立服務部，主推國內市場，成立一鋒樺傳動設備(上海)有限公司，匹配大量產品庫存，協同伺服電機廠家及系統集成貿易商，扎根國內市場，立志通過優良的產品服務於國內自動化行業和機器人領域，為中國機器人事業和工業4.0方向服務。

Jiangsu Fenghua Transmission Technology Co., Ltd. is developed from a factory which professionally manufactures the gears. All staffs of factory and R & D team have more than 20 years' gear manufacturing and designing experience. The factory cooperated with Taiwan planetary gearbox technology team in the early period, and then established business department of the planetary gearbox, and developed the design and manufacturing process of product line of planetary gearbox series. Later, we developed and produced multi-joint robot industry reducers (RV high-precision pin-wheel reducers) with the Japanese NDK company, and the wave gear device (harmonic reducers) invented by American genius inventor C. W. Musser.

Harmonic reducer is composed of three components of wave generator, flexspline and circular spline. The product utilizes the transmission mode of metal winding deformation, and through the breakthrough of tooth meshing and material and processing accuracy, the company successfully developed CSG, CSF, SHG, SHF, SHD series harmonic reducer products, which are widely applied in horizontal reciprocating joint motion occasions like SCARA horizontal multi-joint robots.

RV high-precision cycloidal pinwheel reducer is composed of a cycloid pin wheel and a planet carrier. It features of small volume, strong impact resistance, large torque and high positioning accuracy, small vibration, large reduction ratio, etc. RV-E and RV-C series reducers are widely used in six-axis industrial robots, palletizing robots, and other robot fields like welding robots and positioners in the welding fields, and stamping robots in the punching field. Combined with the application of peripheral automation, Fenghua company developed the RV-EM, RV-CM, FHA & FHD series reducers models for direct-connected motor, which is more convenient for customers to choose and implement.

Fenghua high-precision reducers can directly replace the products manufactured by Germany and Japanese company. Fenghua product series range are full, and sizes and precision can be perfectly matched with the gearbox produced by Japanese & German manufacturers. The products are widely used in six-axis industrial robots, SCARA horizontal multi-joint robots, parallel robots, and palletizing robots, as well as welding robots in the welding field, positioners, stamping robots in the punching field, and rotating application of the fourth & fifth axis in the machine tool industry, and rotary positioning control in the fields of 3C, semiconductor and high-end medical devices. And Fenghua harmonic reducers can be found having been long-term applied in the fields of photovoltaic equipment, lithium battery and other new energy equipment.

The factory set up a service department in mainland of China in the early period, mainly promoting domestic market, and later established Fenghua Transmission Equipment (Shanghai) Co., Ltd. The company matches a large stocks of products to coordinate with servo motor manufacturers and system integration traders, rooting in the domestic market, and determined to serve the domestic automatic industry and robotic field by excellent products and serve for the Chinese robot cause and Industrial 4.0 direction.

低噪音內螺旋齒輪設計
Low noise internal helical gear design

高精度客制化服務
High Precision
Customized Service

創新研發品質保證
Innovative R & D
Quality Assurance

專業加工二十年經驗
Professional Processing
20 Years of Experience

产品目录 CONTENTS

PAGES

技术资料

Technical Data

06-19

CSG/CSF 系列組合型

CSG/CSF Series

20-35



SHG/SHF 系列組合型

SHG/SHF Series

36-56



CSD 系列組合型

CSD Series

57-64



SHD 系列組合型

SHD Series

65-73



產品應用行業 Product Application Industry

半導體液晶製造設備、機器人、機床等需要精密運動控制的前沿領域得到廣泛應用
Semiconductor liquid crystal manufacturing equipment, robots, machine tools, and other frontiers of precision motion control are widely used.

機器人的行走軸 (齒條和小齒輪) The walking shaft of a robot (rack and pinion) 	機床的龍門機器人 Gantry robot of machine tool 	水平多關節機器人 Horizontal multi-joint robot 	晶圓搬運機器人 Wafer handling robot
衝壓設備 (鉚接) Stamping equipment (riveting) 	彎管機 Pipe bending machine 	注塑成型取出機器人 Injection mold taken-out robot 	機床的轉塔刀架旋轉 Rotary tower knife frame rotation of machine tool
機床的XY軸 The XY axis of machine tool 	分度工作臺驅動 Indexing table drive 	塗抹用輓驅動 Roller drive for daubing use 	裝載機用滑車 Pulley for loader use
軸輸入型皮帶驅動 Shaft input belt drive 	液晶玻璃基板搬運機器人 Liquid crystal glass substrate handling robot 	拉力試驗機 Tensile testing machine 	頂棚行走式搬運車 Roof walking van

無人搬運車 Unmanned vehicle 	高度工作用機器人 Robot for working in height 	卷起 Roll up
旋轉 Rotate 	搬送 Transport 	角度 (定位) 控制 Angle (positioning) control
兩軸控制 (XY工作臺) Two axis control (XY workbench) 	輓驅動 Roller drive 	
彎管機 Pipe bending machine 	衝壓 (鉚接) Punching (riveting) 	印刷電路板檢查裝置 Printed circuit board inspection device

锋桦谐波减速机的构造

Structure of FH



波发生器 Wave Generator 柔轮 Flex Spline 刚轮 Circular Spline

3个基本部件组合而成的状态
Three basic components are assembled

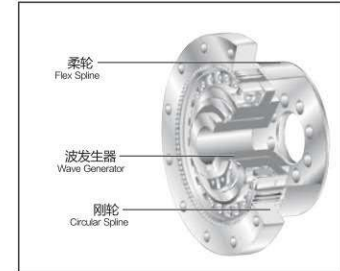

齿轮的啮合状态
Teeth meshing

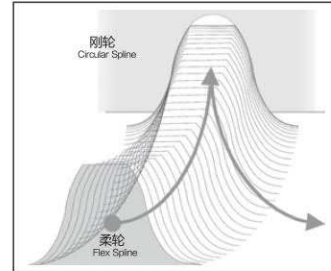

波发生器 Wave Generator

椭圆形凸轮外围嵌有薄壁滚珠轴承，部件整体呈椭圆形。轴承内轮固定在椭圆形凸轮上，外轮通过滚珠可弹性变形。安装在电动机轴上。

A ball bearing with thin-walled construction is fitted onto the outer circumference of an oval cam. The entire structure is oval. The inner ring of the bearing is fixed onto the oval cam and the outer ring elastically deforms through a ball. The wave generator can be mounted on a motor shaft.

刚轮 Flex Spline

刚体的内齿轮。内圈嵌有与柔轮同等大小的齿轮，齿数比柔轮多两个。通常固定在齿轮箱内。

The inner gear of the rigid body, with teeth of equivalent size to those on the flex spline cut into the inner circumference. The circular spline has two more teeth than the flex spline and is normally fixed onto the gear casing.

柔轮 Flex Spline

薄壁杯状的金属弹性体部件。杯子开口部外围刻有齿轮。通常从这里执行输出。

A cup-like elastic metal part with thin wall thickness. Teeth are cut into the outer circumference of the opening of the cup, from where the output is usually extracted.

锋桦谐波减速机的工作原理

Operating Principles of FH

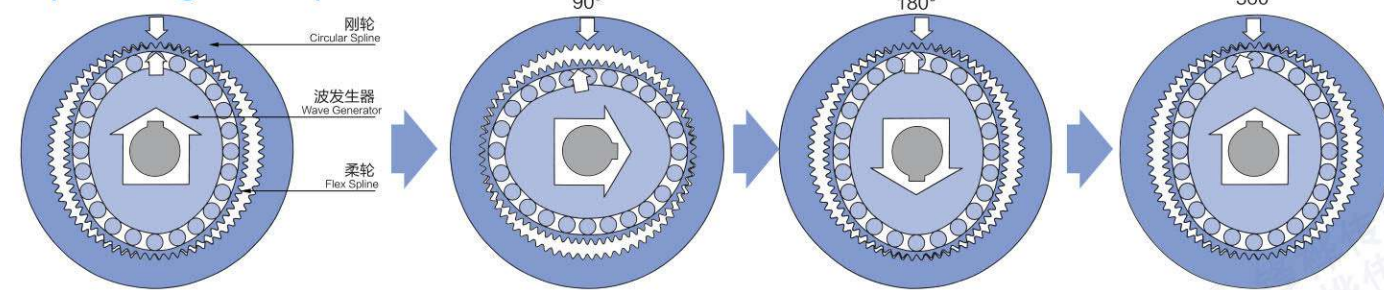

波发生器使柔轮的形状变成椭圆形。因此，在椭圆形长轴的部分，柔轮与刚轮的齿轮啮合；在短轴的部分，齿轮呈完全脱离的状态。The flex spline is bent into an oval shape by the wave generator. Teeth on the long axis of the oval therefore mesh with the circular spline, while the teeth on the short axis of the oval perfectly detach from the circular spline.

固定刚轮，顺时针方向旋转波发生器，柔轮发生弹性变形，与刚轮的齿轮啮合部位顺次移动。Fixing the circular spline and rotating the wave generator clockwise will move the flex spline counter-clockwise, sequentially moving the tooth meshing positions with the circular spline.

将波发生器顺时针旋转180度，柔轮以1齿之差，向逆时针方向移动。Rotating the wave generator through 180° in a clockwise direction will move the flex spline counter-clockwise by one tooth as a difference in the number of teeth.

波发生器旋转1次（360度），柔轮的齿数比刚轮少两个，以2齿之差向逆时针方向移动。一般将该动作作为输出执行。When the wave generator moves counter-clockwise by two teeth based on the difference in the number of teeth because the flex spline has two teeth fewer than the

Rotational direction and reduction ratio

Cup Style

Series: CSG, CSF, CSD, CSF-mini

Rotational direction

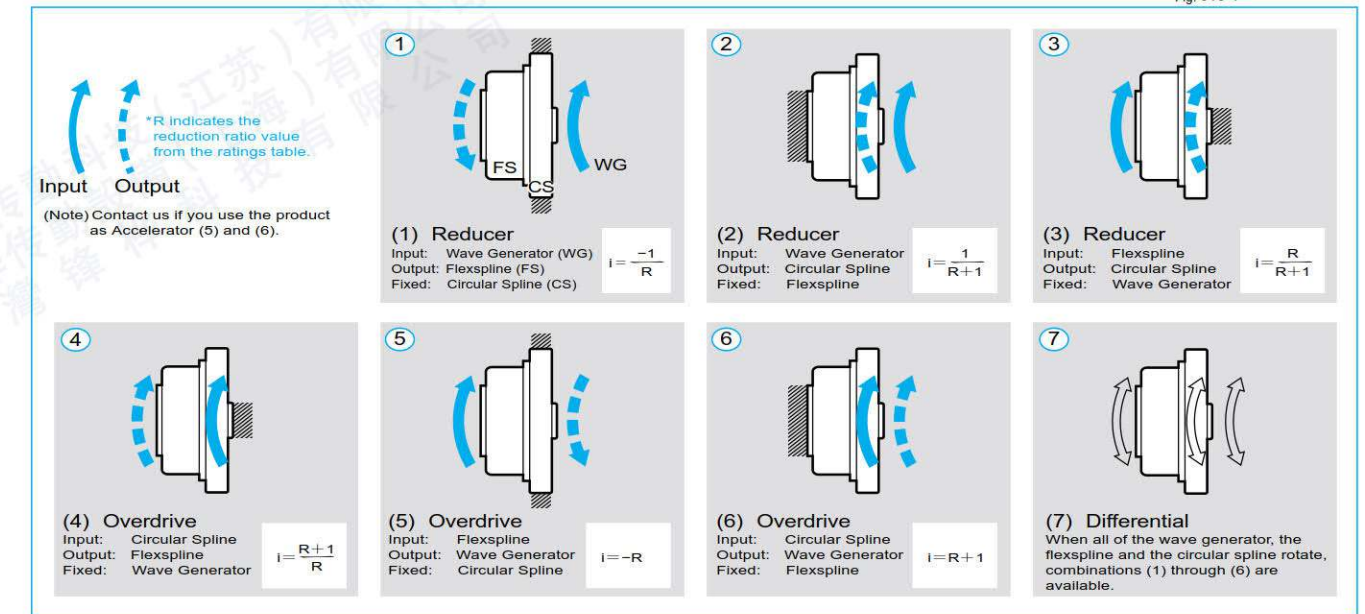

Silk hat

Series: SHG, SHF, SHD

Rotational direction

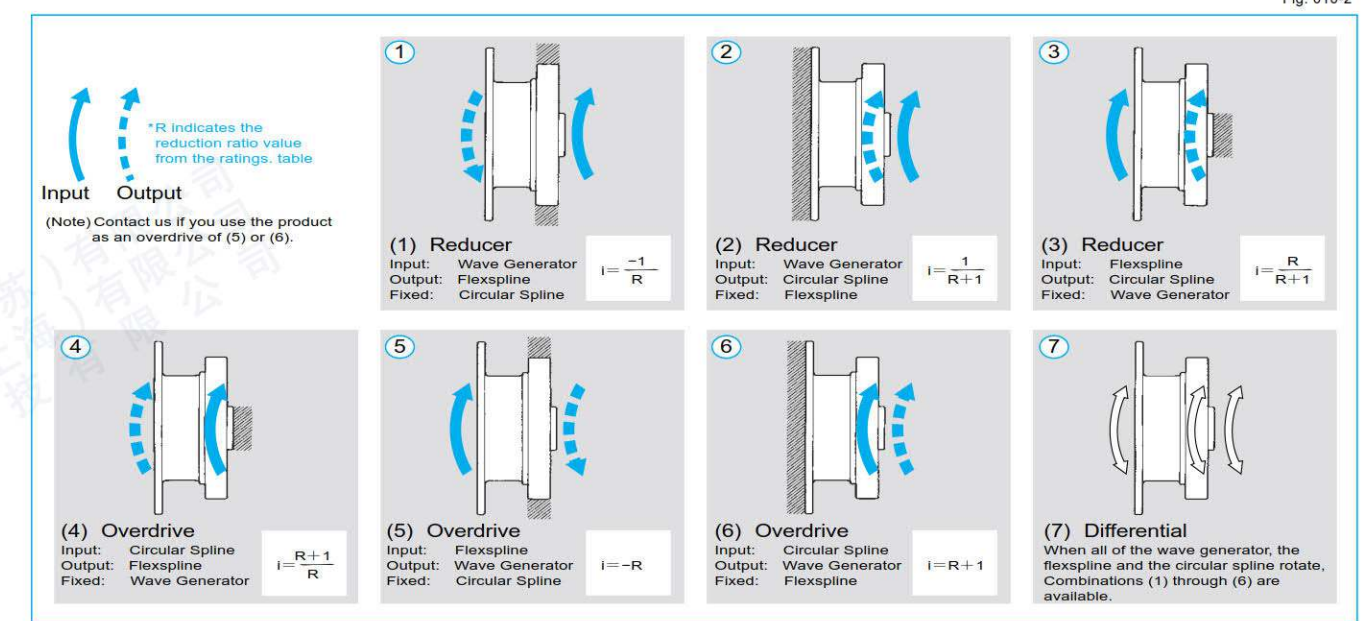

Reduction ratio

The reduction ratio is determined by the number of teeth of the Flexspline and the Circular Spline

Number of teeth of the Flexspline: Z_f
Number of teeth of the Circular Spline: Z_c

Input: Wave Generator
Output: Flexspline
Fixed: Circular Spline } Reduction ratio $i_1 = \frac{1}{R_1} = \frac{Z_f - Z_c}{Z_f}$

Input: Wave Generator
Output: Circular Spline
Fixed: Flexspline } Reduction ratio $i_2 = \frac{1}{R_2} = \frac{Z_c - Z_f}{Z_c}$

Example

Number of teeth of the Flexspline: 200
Number of teeth of the Circular Spline: 202

Input: Wave Generator
Output: Flexspline
Fixed: Circular Spline } Reduction ratio $i_1 = \frac{1}{R_1} = \frac{200 - 202}{200} = \frac{-1}{100}$

Input: Wave Generator
Output: Circular Spline
Fixed: Flexspline } Reduction ratio $i_2 = \frac{1}{R_2} = \frac{202 - 200}{202} = \frac{1}{101}$

*R₁ indicates the reduction ratio value from the ratings table.

Product Sizing & Selection

In general, a servo system rarely operates at a continuous load and speed. The input rotational speed, load torque change and comparatively large torque are applied at start and stop. Unexpected impact torque may be applied. These fluctuating load torques should be converted to the average load torque when selecting a model number. As an accurate cross roller bearing is built in the direct external load support (output flange), the maximum moment load, life of the cross roller bearing and the static safety coefficient should also be checked.

Checking the application motion profile

Review the application motion profile. Check the specifications shown in the figure below.

Graph 14-1

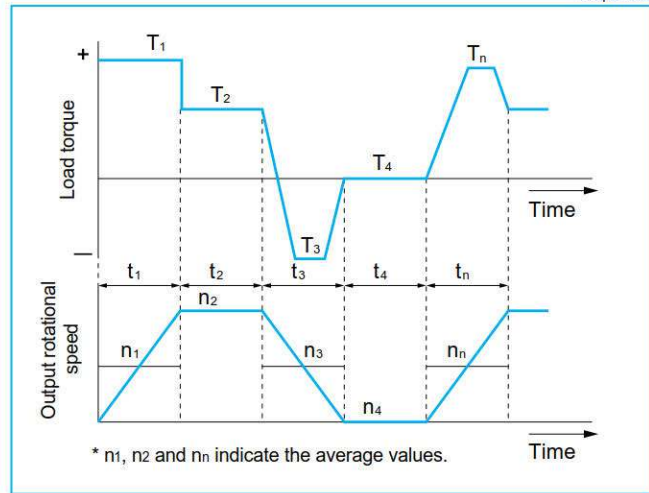

* n1, n2 and n3 indicate the average values.

Obtain the value of each application motion profile.	
Load torque	T_n (Nm)
Time	t_n (sec)
Output rotational speed	n_n (rpm)
Normal operation pattern	
Starting (acceleration)	T_1, t_1, n_1
Steady operation (constant velocity)	T_2, t_2, n_2
Stopping (deceleration)	T_3, t_3, n_3
Dwell	T_4, t_4, n_4
Maximum rotational speed	
Max. output speed	no max
Max. input rotational speed (Restricted by motors)	ni max
Emergency stop torque	
When impact torque is applied	T_s, t_s, n_s
Required life	$L_{10} = L$ (hours)

Flowchart for selecting a size

Please use the flowchart shown below for selecting a size. Operating conditions must not exceed the performance ratings.

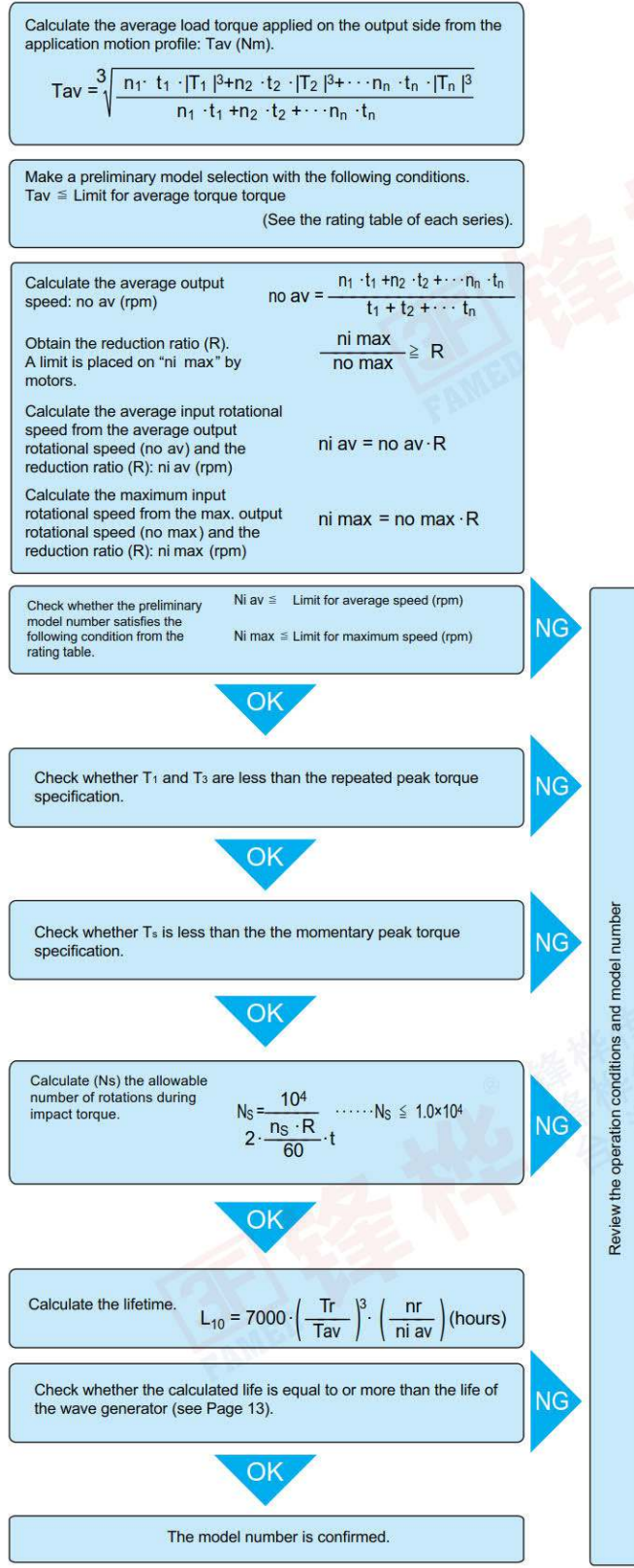

Example of model number selection

Value of each application motion profile		Maximum rotational speed	
Load torque	T_n (Nm)	Max. output speed	no max = 14 rpm
Time	t_n (sec)	Max. input speed	ni max = 1800 rpm
Output speed	n_n (rpm)	(Restricted by motors)	
Normal operation pattern		Emergency stop torque	
Starting (acceleration)	$T_1 = 400$ Nm, $t_1 = 0.3$ sec, $n_1 = 7$ rpm	When impact torque is applied	$T_s = 500$ Nm, $t_s = 0.15$ sec, $n_s = 14$ rpm
Steady operation (constant velocity)	$T_2 = 320$ Nm, $t_2 = 3$ sec, $n_2 = 14$ rpm	Required life	$L_{10} = 7000$ (hours)
Stopping (deceleration)	$T_3 = 200$ Nm, $t_3 = 0.4$ sec, $n_3 = 7$ rpm		
Dwell	$T_4 = 0$ Nm, $t_4 = 0.2$ sec, $n_4 = 0$ rpm		

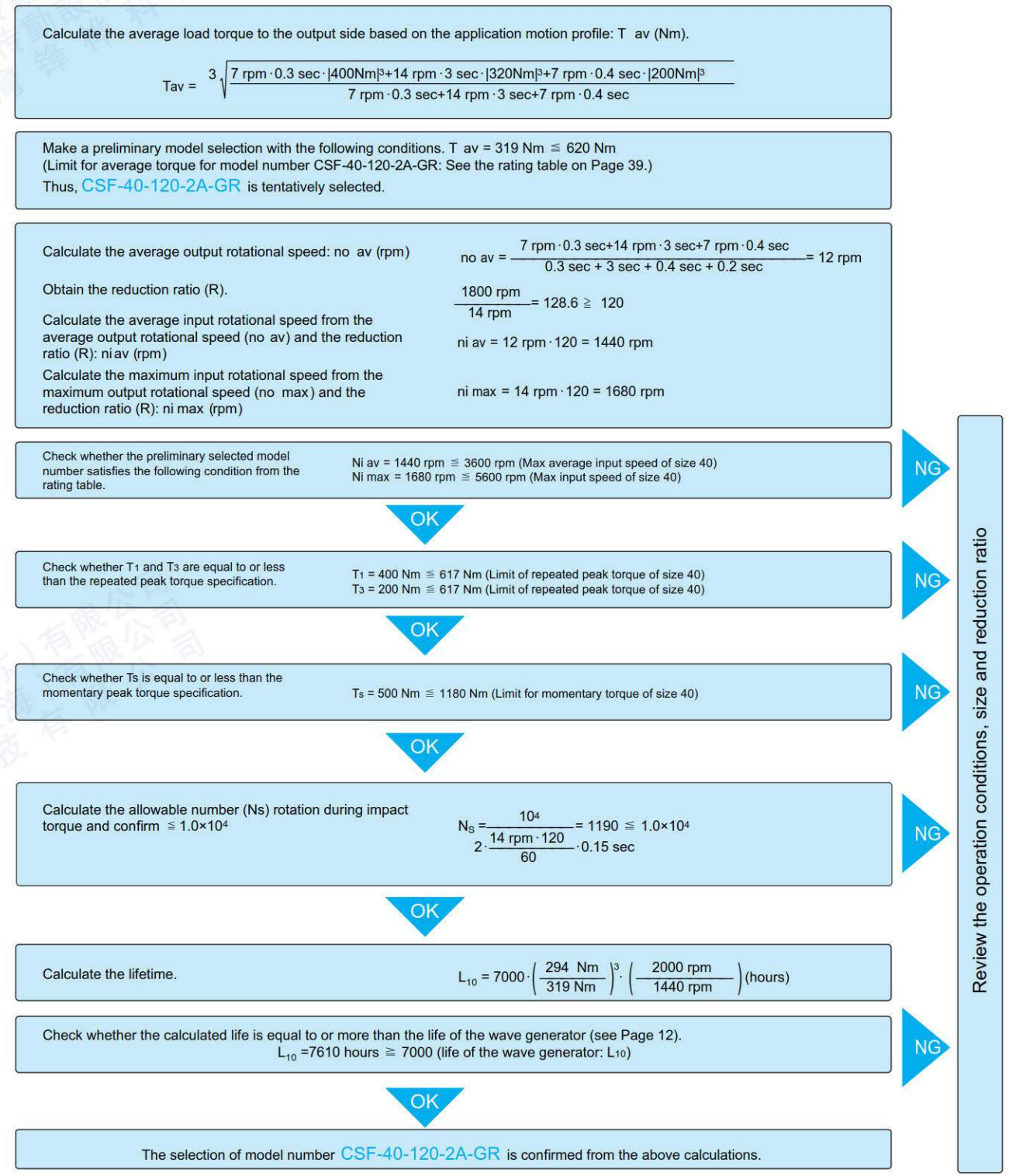

Review the operation conditions, size and reduction ratio

Lubrication

Component Sets: CSD-2A, CSF-2A, CSG-2A, FB-2, FB-0, FR-2, SHF-2A, SHG-2A and SHD and SHG/SHF -2SO and -2SH gear units: Grease lubricant and oil lubricant are available for lubricating the component sets and SHD gear unit. It is extremely important to properly grease your component sets and SHD gear unit. Proper lubrication is essential for high performance and reliability. Harmonic Drive® component sets are shipped with a rust- preventative oil. The characteristics of the lubricating grease and oil types approved by Harmonic Drive are not changed by mixing with the preservation oil. It is therefore not necessary to remove the preservation oil completely from the gear components. However, the mating surfaces must be degreased before the assembly.

Gear Units: CSG/CSF 2UH and 2UH-LW; CSD-2UF and -2UH; SHG/SHF-2UH and 2UH-LW; SHG/SHF-2UJ; CSF Supermini, CSF Mini, and CSF-2UP. Grease lubricant is standard for lubricating the gear units. You do not need to apply grease during assembly as the product is lubricated and shipped. See Page 19 for using lubricant beyond the temperature range in table 16-2.

* Contact us if you want consistency zero (NLGI No.0) for maintenance reasons.

Grease lubricant

Types of lubricant

Harmonic Grease® SK-1A
This grease was developed for Harmonic Drive® gears and features good durability and efficiency.

Harmonic Grease® SK-2
This grease was developed for small sized Harmonic Drive® gears and features smooth rotation of the Wave Generator since high pressure additive is liquefied.

Harmonic Grease® 4B No.2
This has been developed exclusively for the CSF and CSG and features long life and can be used over a wide range of temperature.

- (Note)
- Grease lubrication must have proper sealing, this is essential for 4B No.2. Rotating part: Oil seal with spring is needed. Mating part: O ring or seal adhesive is needed.
 - The grease has the highest deterioration rate in the region where the grease is subjected to the greatest shear (near wave generator). Its viscosity is between JIS No.0 and No.00 depending on the operation.

Table 016-3

NLGI consistency No.	Mixing consistency range
0	355 to 385
00	400 to 430

Grease specification

Table 016-4

Grease	SK-1A	SK-2	4B No.2
Base oil	Refined oil	Refined oil	Composite hydrocarbon oil
Base Viscosity cSt (25°C)	265 to 295	265 to 295	290 to 320
Thickening agent	Lithium soap base	Lithium soap base	Urea
NLGI consistency No.	No. 2	No. 2	No. 1.5
Additive	Extreme-pressure additive, others	Extreme-pressure additive, others	Extreme-pressure additive, others
Drop Point	197°C	198°C	247°C
Appearance	Yellow	Green	Light yellow
Storage life	5 years in sealed condition	5 years in sealed condition	5 years in sealed condition

Name of lubricant

Table 016-1

Grease	Harmonic Grease® SK-1A
	Harmonic Grease® SK-2
	Harmonic Grease® 4B No.2
Oil	Industrial gear oil class-2 (extreme pressure) ISO VG68

Temperature

Table 016-2

Grease	SK-1A 0°C to +40°C
	SK-2 0°C to +40°C
	4B No.2 -10°C to +70°C
Oil	ISO VG68 0°C to +40°C

* The hottest section should not be more than 40° above the ambient temperature.

Note: The three basic components of the gear - the Flexspline, Wave Generator and Circular Spline - are matched and serialized in the factory. Depending on the product they are either greased or prepared with preservation oil. Then the individual components are assembled. If you receive several units, please be careful not to mix the matched components. This can be avoided by verifying that the serial numbers of the assembled gear components are identical.

Compatible grease by size

Compatible grease varies depending on the size and reduction ratio. See the following compatibility table. We recommend SK-1A and SK-2 for general use.

Ratios 30:1

Table 016-5

Size	8	11	14	17	20	25	32
SK-1A	—	—	—	—	○	○	○
SK-2	○	○	○	○	—	—	—
4B No.2	△	△	△	△	□	□	□

Ratios 50:1* and above

Table 016-6

Size	8	11	14	17	20	25	32
SK-1A	—	—	—	—	○	○	○
SK-2	○	○	○	○	△	△	△
4B No.2	—	—	□	□	□	□	□

Size	40	45	50	58	65	80	90	100
SK-1A	○	○	○	○	○	○	○	○
SK-2	△	—	—	—	—	—	—	—
4B No.2	□	□	□	□	□	□	□	□

- : Standard grease
- △ : Semi-standard grease
- : Recommended grease for long life and high load

* Oil lubrication is required for component-sets size 50 or larger with a reduction ratio of 50:1.

Grease characteristics

Table 016-7

Grease	SK-1A	SK-2	4B No.2
Durability	○	○	◎
Fretting resistance	○	○	◎
Low-temperature performance	△	△	◎
Grease leakage	◎	◎	△

- Excellent : ◎
- Good : ○
- Use Caution : △

When to replace grease

The wear characteristics of the gear are strongly influenced by the condition of the grease lubrication. The condition of the grease is affected by the ambient temperature. The graph 017-1 shows the maximum number of input rotations for various temperatures. This graph applies to applications where the average load torque does not exceed the rated torque.

Calculation formula when the average load torque exceeds the rated torque

Formula 017-1

$$L_{OT} = L_{OTn} \times \left(\frac{Tr}{Tav} \right)^3$$

Other precautions

- Avoid mixing different kinds of grease. The gear should be in an individual case when installed.
- Please contact us when you use Harmonic Drive® gears at constant load or in one direction continuously, as it may cause lubrication problems.
- Grease leakage. A sealed structure is needed to maintain the high durability of the gear and prevent grease leakage.

See the corresponding pages of the design guide of each series for "Recommended minimum housing clearance," "Application guide" and "Application quantity."

Oil lubricant

Types of oil

The specified standard lubricant is "Industrial gear oil class-2 (extreme pressure) ISO VG68." We recommend the following brands as a commercial lubricant.

Standard	Mobil Oil	Exxon	Shell	COSMO Oil	Japan Energy	NIPPON Oil	Idemitsu Kosan	General Oil	Klüber
Industrial gear oil class-2 (extreme pressure) ISO VG68	Mobilgear 600XP68	Spartan EP68	Omala Oil 68	Cosmo gear SE68	ES gear G68	Bonock M68, Bonock AX68	Daphne super gear LW68	General Oil SP gear roll 68	Syntheso D-68EP

Table 018-1

When to replace oil

First time 100 hours after starting operation
Second time or after Every 1000 operation hours or every 6 months
Note that you should replace the oil earlier than specified if the operating condition is demanding.

See the corresponding pages of the design guide of each series for specific details.

Lubricant for special environments

When the ambient temperature is special (other than the "temperature range of the operating environment" on Page 016-2), you should select a lubricant appropriate for the operating temperature range.

High temperature lubricant

Table 019-2

Type of lubricant	Lubricant and manufacturer	Available temperature range
Grease	Mobil grease 28: Mobil Oil	-5°C to +160°C
Oil	Mobil SHC-626: Mobil Oil	-5°C to +140°C

Low temperature lubricant

Table 019-3

Type of lubricant	Lubricant and manufacturer	Available temperature range
Grease	Multemp SH-KII: Kyodo Oil	-30°C to +50°C
	Isoflex LDS-18 special A: KLÜBER	-25°C to +80°C
Oil	SH-200-100CS: Toray Silicon	-40°C to +140°C
	Syntheso D-32EP: KLÜBER	-25°C to +90°C

Formula Symbols

Table 017-1

L_{OT}	Grease change (if average load torque exceeds rated torque)	input revolutions	—
L_{OTn}	Grease change (if average load torque is equal to or less than rated torque)	input revolutions (From Graph)	See the Graph 017-1.
Tr	Rated torque	Nm	See the "Ratings Table" of each series.
Tav	Average load torque	Nm	Calculation formula: See Page 014.

Torsional Stiffness

Stiffness and backlash of the drive system greatly affects the performance of the servo system. Please perform a detailed review of these items before designing your equipment and selecting a model number.

■ Stiffness

Fixing the input side (wave generator) and applying torque to the output side (flexspline) generates torsion almost proportional to the torque on the output side. Figure 018-1 shows the torsional angle at the output side when the torque applied on the output side starts from zero, increases up to $+T_0$ and decreases down to $-T_0$. This is called the "Torque – torsion angle diagram," which normally draws a loop of $0 - A - B - A' - B' - A$. The slope described in the "Torque – torsion angle diagram" is represented as the spring constant for the stiffness of the HarmonicDrive® gear (unit: Nm/rad).

As shown in Figure 020-1, this "Torque – torsional angle diagram" is divided into 3 regions, and the spring constants in the area are represented by K_1 , K_2 and K_3 .

K_1 ... The spring constant when the torque changes from [zero] to [T_1]
 K_2 ... The spring constant when the torque changes from [T_1] to [T_2]
 K_3 ... The spring constant when the torque changes from [T_2] to [T_3]

■ See the corresponding pages of each series for values of the spring constants (K_1 , K_2 , K_3) and the torque-torsional angles (T_1 , T_2 , $- \theta_1$, θ_2).

■ Example for calculating the torsion angle

The torsion angle (θ) is calculated here using CSF-25-100-2A-GR as an example.

When the applied torque is T_{L1} or less, the torsion angle θ_{L1} is calculated as follows:

$$\begin{aligned} \theta_{L1} &= T_{L1}/K_1 \\ &= 2.9/3.1 \times 10^4 \\ &= 9.4 \times 10^{-5} \text{ rad (0.33 arc min)} \end{aligned}$$

When the applied torque is between T_1 and T_2 , the torsion angle θ_{L2} is calculated as follows:

$$\begin{aligned} \theta_{L2} &= \theta_1 + (T_{L2} - T_1)/K_2 \\ &= 4.4 \times 10^{-4} + (39 - 14)/5.0 \times 10^4 \\ &= 9.4 \times 10^{-4} \text{ rad (3.2 arc min)} \end{aligned}$$

When a bidirectional load is applied, the total torsion angle will be $2 \times \theta_{Lx}$ plus hysteresis loss.

* The torsion angle calculation is for the gear component set only and does not include any torsional windup of the output shaft.

Note: See p.120 for torsional stiffness for pancake gearing.

■ Hysteresis loss (Silk hat and cup style only)

As shown in Figure 020-1, when the applied torque is increased to the rated torque and is brought back to [zero], the torsional angle does not return exactly back to the zero point. This small difference ($B - B'$) is called hysteresis loss.

■ See the corresponding page of each series for the hysteresis loss value.

Torque - torsion angle diagram

Figure 20-1

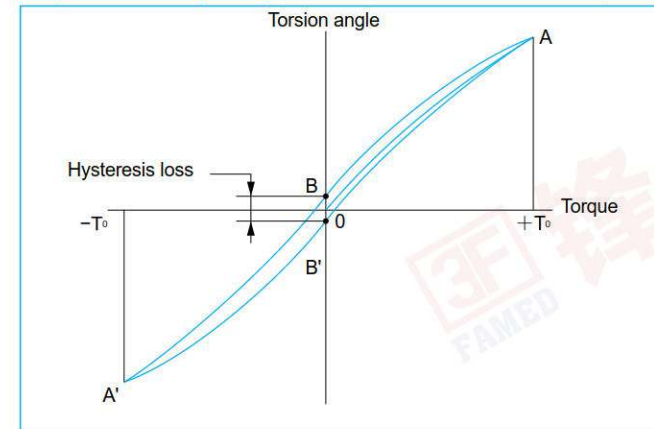

Spring constant diagram

Figure 20-2

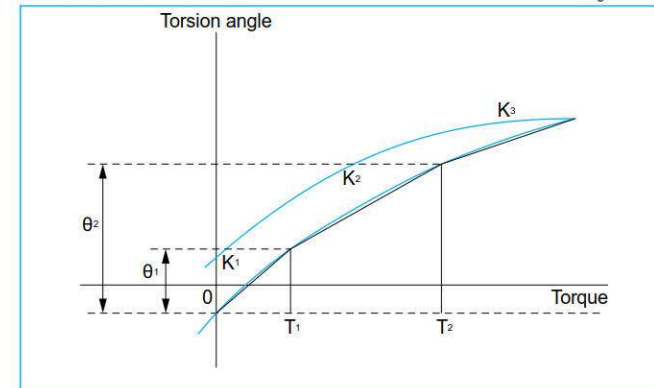

■ Backlash (Silk hat and cup style only)

Hysteresis loss is primarily caused by internal friction. It is a very small value and will vary roughly in proportion to the applied load. Because HarmonicDrive® gears have zero backlash, the only true backlash is due to the clearance in the Oldham coupling, a self-aligning mechanism used on the wave generator. Since the Oldham coupling is used on the input, the backlash measured at the output is extremely small (arc-seconds) since it is divided by the gear reduction ratio.

Torque Limits

■ Strength of flexspline

The Flexspline is subjected to repeated deflections, and its strength determines the torque capacity of the Harmonic Drive® gear. The values given for Rated Torque at Rated Speed and for the allowable Repeated Peak Torque are based on an infinite fatigue life for the Flexspline.

The torque that occurs during a collision must be below the momentary peak torque (impact torque). The maximum number of occurrences is given by the equation below.

■ Buckling torque

When a highly excessive torque (16 to 17 times rated torque) is applied to the output with the input stationary, the flexspline may experience plastic deformation. This is defined as buckling torque.

* See the corresponding pages of each series for buckling torque values.

■ Ratcheting torque

When excessive torque (8 to 9 times rated torque) is applied while the gear is in motion, the teeth between the Circular Spline and Flexspline may not engage properly. This phenomenon is called ratcheting and the torque at which this occurs is called ratcheting torque. Ratcheting may cause the Flexspline to become non-concentric with the Circular Spline. Operating in this condition may result in shortened life and a Flexspline fatigue failure.

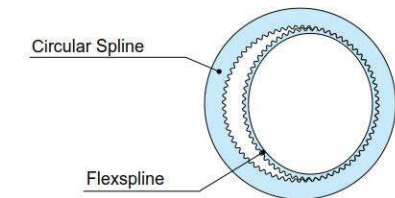

Figure 013-1

"Dedoidal" condition.

Positional Accuracy

Positional Accuracy values represent the difference between the theoretical angle and the actual angle of output for any given input. The values shown in the table are maximum values.

■ See the corresponding pages of each series for transmission accuracy values.

Example of measurement

Graph 021-1

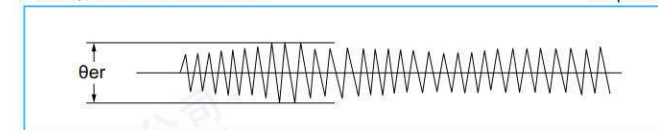

Table 021-1

θ_{er}	Transmission accuracy
θ_1	Input angle
θ_2	Actual output angle
R	Reduction ratio

Formula 021-1

$$\theta_{er} = \theta_2 - \frac{\theta_1}{R}$$

Vibration

The primary frequency of the transmission error of the Harmonic Drive® gear may cause a vibration of the load inertia. This can occur when the driving frequency of the servo system including the Harmonic Drive® gear is at, or close to the resonant frequency of the system. Refer to the design guide of each series.

The primary component of the transmission error occurs twice per input revolution of the input. Therefore, the frequency generated by the transmission error is 2x the input frequency (rev / sec).

If the resonant frequency of the entire system, including the Harmonic Drive® gear, is $F = 15$ Hz, then the input speed (N) which would generate that frequency could be calculated with the formula below.

Formula 021-2

$$N = \frac{15}{2} \cdot 60 = 450 \text{ rpm}$$

The resonant frequency is generated at an input speed of 450 rpm.

How to the calculate resonant frequency of the system

Formula 021-3

$$f = \frac{1}{2\pi} \sqrt{\frac{K}{J}}$$

Formula variables

Table 021-2

f	The resonant frequency of the system	Hz	
K	Spring constant	Nm/rad	See pages of each series
J	Load inertia	kgm ²	

Rating Table Definitions

See the corresponding pages of each series for values.

- Rated torque**
 Rated torque indicates allowable continuous load torque at rated input speed.
- Limit for Repeated Peak Torque (see Graph 12-1)**
 During acceleration and deceleration the Harmonic Drive® gear experiences a peak torque as a result of the moment of inertia of the output load. The table indicates the limit for repeated peak torque.
- Limit for Average Torque**
 In cases where load torque and input speed vary, it is necessary to calculate an average value of load torque. The table indicates the limit for average torque. The average torque calculated must not exceed this limit. (calculation formula: Page 14)
- Limit for Momentary Peak Torque (see Graph 12-1)**
 The gear may be subjected to momentary peak torques in the event of a collision or emergency stop. The magnitude and frequency of occurrence of such peak torques must be kept to a minimum and they should, under no circumstance, occur during normal operating cycle. The allowable number of occurrences of the momentary peak torque may be calculated by using formula 13-1.
- Maximum Average Input Speed Maximum Input Speed**
 Do not exceed the allowable rating. (calculation formula of the average input speed: Page 14).
- Moment of Inertia**
 The rating indicates the moment of inertia reflected to the gear input.

Life of the wave generator

- Life of the wave generator**
 The life of a gear is determined by the life of the wave generator bearing. The life may be calculated by using the input speed and the output load torque.

Table 012-1

Series name	Life	
	CSF, CSD, SHF, SHD, CSF-mini	CSG, SHG
L ₁₀	7,000 hours	10,000 hours
L ₅₀ (average life)	35,000 hours	50,000 hours

* Life is based on the input speed and output load torque from the rating table.

Calculation formula for Rated Lifetime

Formula 012-1

$$L_h = L_n \cdot \left(\frac{T_r}{T_{av}} \right)^3 \cdot \left(\frac{N_r}{N_{av}} \right)$$

Table 012-2

L _n	Life of L ₁₀ or L ₅₀
T _r	Rated torque
N _r	Rated input speed
T _{av}	Average load torque on the output side (calculation formula: Page 14)
N _{av}	Average input speed (calculation formula: Page 14)

On starting torque

Starting torque refers to that when FH harmonic reducer is mounted on the shell and applied torque to the input side (high-speed side), "start-up torque" produced by the instantaneous rotation of the output side (low-speed side). The values shown in the series tables are the maximum and the lower limit is about 1/2-1/3 of the maximum.

On increasing starting torque

Increasing starting torque refers to that when FH harmonic reducer is mounted on the shell and applied torque to the input side (high-speed side), "start-up torque" produced by the instantaneous rotation of the output side (low-speed side). The values shown in the series tables are the maximum, and the lower limit is about 1/2 of the maximum.

Load-free operating torque

Load-free operating torque refers to the necessary input side (high-speed axle side) torque for rotating the FH harmonic reducer under no-load conditions. For reduction ratios other than 100, please add the correction amount shown in each series to calculate.

Efficiency characteristics

Efficiency varies according to the following conditions.

- Reduction ratio
 - Input speed
 - Load torque
 - Temperature
 - Lubrication conditions (types and its amount of use)
 - Efficiency correction coefficient
- When the load torque is less than the rated torque, the efficiency decreases.

Please calculate the correction coefficient K_e according to the series of efficiency correction coefficient tables, and calculate the efficiency by referring to the following calculation example.

Design Guidelines

Design guideline

The relative perpendicularity and concentricity of the three basic Harmonic Drive® elements have an important influence on accuracy and service life.

Misalignments will adversely affect performance and reliability. Compliance with recommended assembly tolerances is essential in order for the advantages of Harmonic Drive® gearing to be fully realized. Please consider the following when designing:

- Input shaft, Circular Spline and housing must be concentric.
- When operating, an axial force is generated on the wave generator. Input bearings must be selected to accommodate this axial load. See page 27.
- Even though a Harmonic Drive® gear is compact, it transmits large torques. Therefore, assure that all required bolts are used to fastened the circular spline and flexspline and that they are tightened to the recommended torque.
- As the flexspline is subject to elastic deformation, the A minimal clearance between the flexspline and housing is required. Refer to "Minimum Housing Clearance" on the drawing dimension tables.
- The input shaft and output shaft are supported by anti-friction bearings. As the wave generator and flexspline elements are meant to transmit pure torque only, the bearing arrangement needs to isolate the harmonic gearing from external forces applied to either shaft. A common bearing arrangement is depicted in the diagram.
- A clamping plate is recommended (item 6). Its purpose is to spread fastening forces and to avoid any chance of making physical contact with the thin section of the flexspline diaphragm. The clamping plate shall not exceed the diaphragm's boss diameter and is to be designed in accordance with catalog recommendations.

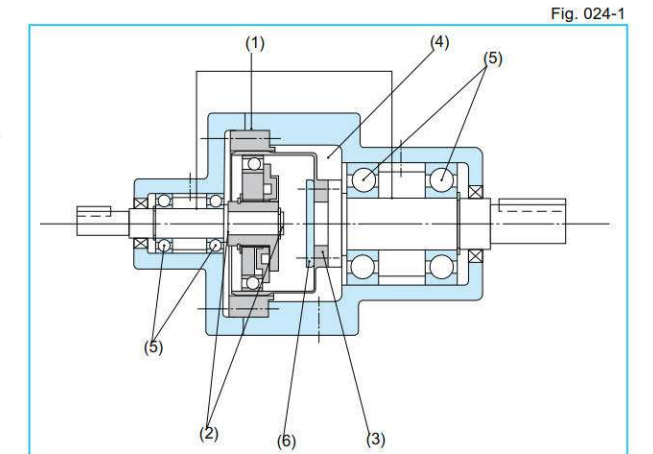

Bearing support for the input and output shafts

For the component sets, both input and output shafts must be supported by two adequately spaced bearings in order to withstand external radial and axial forces without excessive deflection. In order to avoid damage to the component set when limited external loads are anticipated, both input and output shafts must be axially fixed. Bearings must be selected whose radial play does not exceed ISO-standard C 2 class or "normal" class. The bearings should be axially and radially preloaded to eliminate backlash.

Examples of correct bearing arrangements are shown in fig 025-1.

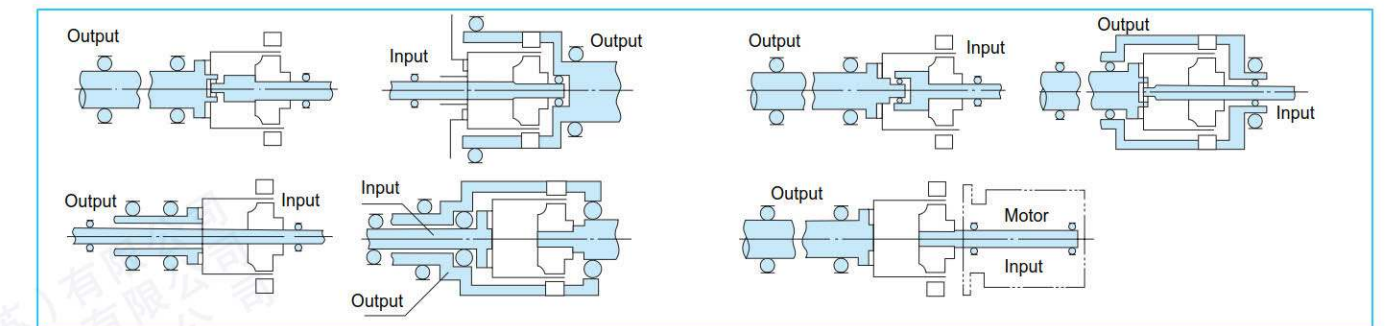

Wave generator

Structure of the wave generator

The wave generator includes an Oldham's coupling type with a self-aligning structure and an integrated solid wave generator without a self-aligning structure, and which is used depends on the series.

See the diagram of each series for details. The basic structure of the wave generator and the shape are shown below.

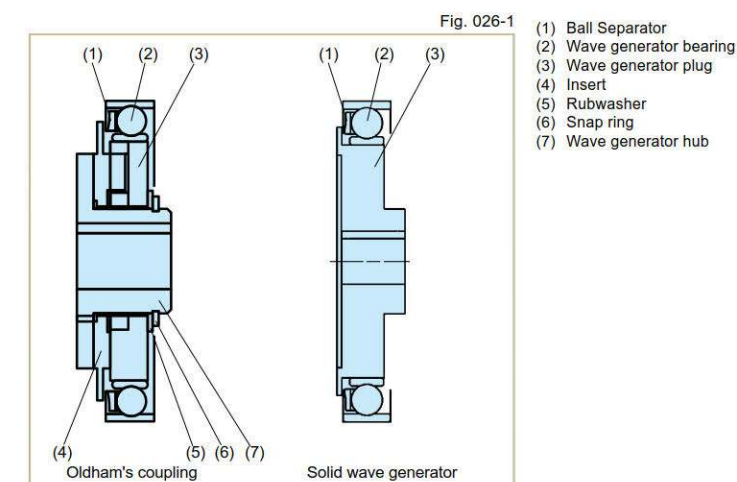

Structure of Oldham's coupling

Fig. 026-2

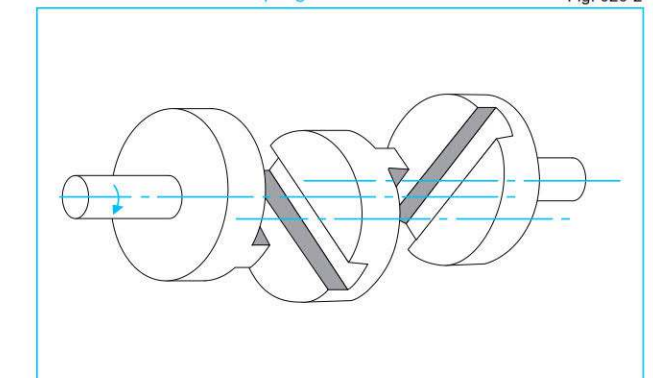

Maximum hole diameter of wave generator

The standard hole dimension of the wave generator is shown for each size. The dimension can be changed within a range up to the maximum hole dimension. We recommend the dimension of keyway based on JIS standard. It is necessary that the dimension of keyways should sustain the transmission torque.

* Tapered holes are also available.

In cases where a larger hole is required, use the wave generator without the Oldham coupling. The maximum diameter of the hole should be considered to prevent deformation of the Wave Generator plug by load torque. The dimension is shown in the table below and includes the dimension of depth of keyway.
(This is the value including the dimension of the depth of keyway.)

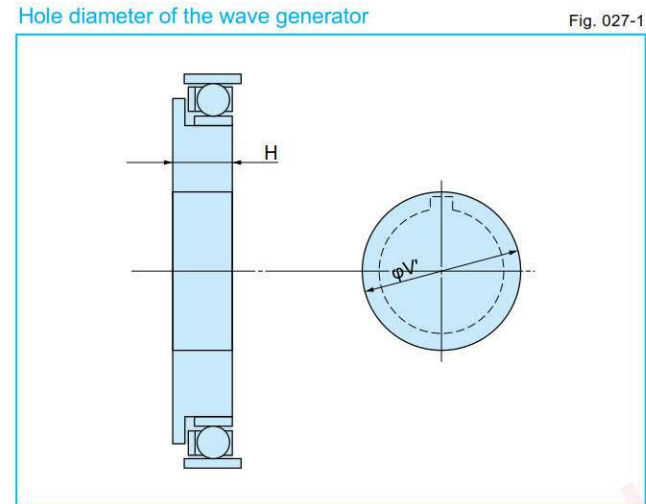

Hole diameter of the wave generator hub with Oldham coupling

Table 027-1
Unit: mm

Size	8	11	14	17	20	25	32	40	45	50	58	65	80	90	100
Standard dim. (H7)	3	5	6	8	9	11	14	14	19	19	22	24	28	28	28
Minimum hole dim.	—	—	3	4	5	6	6	10	10	10	13	16	16	19	22
Maximum hole dim.	—	—	8	10	13	15	15	20	20	20	25	30	35	37	40

Maximum hole diameter without Oldham Coupling

Table 027-2
Unit: mm

Size	8	11	14	17	20	25	32	40	45	50	58	65	80	90	100
Max. hole dia. φV'	10	14	17	20	23	28	36	42	47	52	60	67	72	84	95
Min. plug thick. H _{0.1} ⁰	5.7	6.7	7.2	7.6	11.3	11.3	13.7	15.9	17.8	19	21.4	23.5	28.5	31.3	34.9

Axial Force of Wave Generator

When the gear is used to accelerate a load, the deflection of the Flexspline leads to an axial force acting on the Wave Generator. This axial force, which acts in the direction of the closed end of the Flexspline, must be supported by the bearings of the input shaft (motor shaft). When the gear is used to decelerate a load, an axial force acts to push the Wave Generator out of the Flexspline cup. Maximum axial force of the Wave Generator can be calculated by the equation shown below. The axial force may vary depending on its operating condition. The value of axial force tends to be a larger number when using high torque, extreme low speed and constant operation. The force is calculated (approximately) by the equation. In all cases, the Wave Generator must be axially (in both directions), as well as torsionally, fixed to the input shaft.

(Note)

Please contact us for further information on attaching the Wave Generator to the input (motor) shaft.

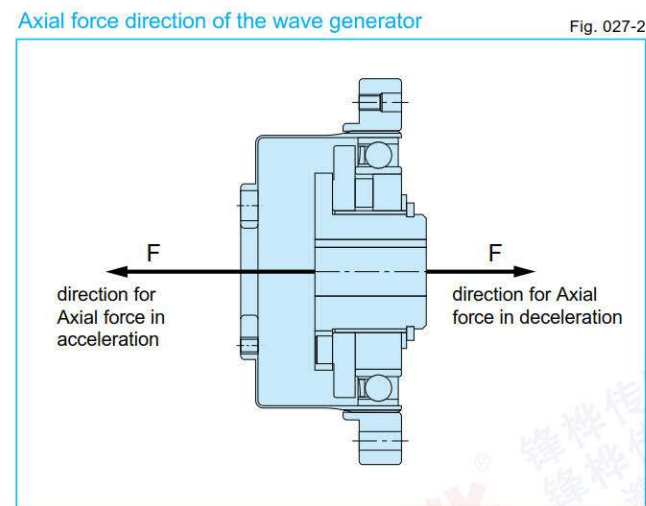

Formula for Axial Force

Table 027-3

Reduction ratio	Calculation formula
30	$F = 2 \times \frac{T}{D} \times 0.07 \times \tan 32^\circ$
50	$F = 2 \times \frac{T}{D} \times 0.07 \times \tan 30^\circ$
80 or more	$F = 2 \times \frac{T}{D} \times 0.07 \times \tan 20^\circ$

Symbols for Formula

Table 027-4

F	Axial force	N	See Figure 027-2
D	Size	m	
T	Output torque	Nm	

Calculation example

Formula 027-1

Model name: CSF series
Size: 32
Reduction ratio: 50
Output torque: 382 Nm
(maximum allowable momentary torque)

$$F = 2 \times \frac{382}{(32 \times 0.00254)} \times 0.07 \times \tan 30^\circ$$

$$F = 380N$$

Assembly Precautions

Sealing

Sealing is needed to maintain the high durability of the gear and prevent grease leakage. Recommended for all mating surfaces, if the o-ring is not used. Flanges provided with o-ring grooves must be sealed when a proper seal cannot be achieved using the o-ring alone.

- Rotating Parts Oil seal with spring is needed.
- Mating flange O-ring or seal adhesive is needed.
- Screw hole area Screws should have a thread lock (LOCTITE® 242 is recommended) or seal adhesive.

(Note) If you use Harmonic Grease 4BNo.2, strict sealing is required.

Assembly precautions

The wave generator is installed after the flexspline and circular spline. If the wave generator is not inserted into the flexspline last, gear teeth scuffing damage or improper eccentric gear mesh may result. Installation resulting in an eccentric tooth mesh (Dedoidal) will cause noise and vibration, and can lead to early failure of the gear. For proper function, the teeth of the flexspline and Circular Spline mesh symmetrically.

Precautions on the wave generator

1. Avoid applying undue axial force to the wave generator during installation. Rotating the wave generator bearing while inserting it is recommended and will ease the process.
2. If the wave generator does not have an Oldham coupling, extra care must be given to ensure that concentricity and inclination are within the specified limits

Precautions on the circular spline

The circular spline must not be deformed in any way during the assembly. It is particularly important that the mounting surfaces are prepared correctly

1. Mounting surfaces need to have adequate flatness, smoothness, and no distortion.
2. Especially in the area of the screw holes, burrs or foreign matter should not be present.
3. Adequate relief in the housing corners is needed to prevent interference with the corner of the circular spline.
4. The circular spline should be rotatable within the housing. Be sure there is not interference and that it does not catch on anything.
5. When a bolt is inserted into a bolt hole during installation, make sure that the bolt fits securely and is not in an improper position or inclination.
6. Do not apply torque at recommended torque all at once. First, apply torque at about half of the recommended value to all bolts, then tighten at recommended torque. Order of tightening bolts must be diagonal.
7. Avoid pinning the circular spline if possible as it can reduce the rotational precision and smoothness of operation.

Sealing recommendations for gear units

Table 028-1

Area requiring sealing		Recommended sealing method
Output side	Holes which penetrate housing	Use O-ring (supplied with the product)
	Installation screw / bolt	Screw lock adhesive which has effective seal (LOCTITE® 242 is recommended)
Input side	Flange surfaces	Use O-ring (supplied with the product)
	Motor output shaft	Please select a motor which has an oil seal on the output shaft.

Precautions on the flexspline

1. Mounting surfaces need to have adequate flatness, smoothness, and no distortion.
 2. Especially in the area of the screw holes, burrs or foreign matter should not be present.
 3. Adequate clearance with the housing is needed to ensure no interference especially with the major axis of flexspline
 4. Bolts should rotate freely when installing through the mounting holes of the flexspline and should not have any irregularity due to the shaft bolt holes being misaligned or oblique.
 5. Do not tighten the bolts with the specified torque all at once. Tighten the bolts temporarily with about half the specified torque, and then tighten them to the specified torque. Tighten them in an even, crisscross pattern.
 6. The flexspline and circular spline are concentric after assembly. After installing the wave generator bearing, if it rotates in unbalanced way, check the mounting for dedoidal or non-concentric installation.
 7. Care should be taken not to damage the flexspline diaphragm or gear teeth during assembly.
- Avoid hitting the tips of the flexpline teeth and circular spline teeth. Avoid installing the CS from the open side of the flexspline after the wave generator has been installed.

Rust prevention

Although the Harmonic Drive® gears come with some corrosion protection, the gear can rust if exposed to the environment. The gear external surfaces typically have only a temporary corrosion inhibitor and some oil applied. If an anti-rust product is needed, please contact us to review the options.

"Dedoidal" state

It is normal for the flexspline to engage with the circular spline symmetrically as shown in Figure 029-1. However, if the ratcheting phenomenon, which is described on Page 013, is caused or if the three parts are forcibly inserted and assembled, engagement of the teeth may be out of alignment as shown in Figure 029-2. This is called "dedoidal". Note: Early failure of the gear will occur.

How to check "dedoidal"

By performing the following methods, check whether the gear engagement is "dedoidal".

(1) Judging by the irregular torque generated when the wave generator turns

- 1) Slowly turn the input shaft with your hand in a no-load condition. If you can turn it with average force, it is normal. If it turns irregularly, it may be "dedoidal".
- 2) Turn the wave generator in a no-load condition if it is attached to a motor. If the average current value of the motor is about 2 to 3 times the normal value, it may be "dedoidal".

(2) Judging by measuring vibration on the body of the flexspline

The scale deflection of the dial gauge draws a sine wave as shown by the solid line in Graph 029-3 when it is normally assembled. When "dedoidal" occurs, the gauge draws a deflected wave shown by the dotted line as the flexspline is out of alignment.

Normal engagement status Fig. 029-1

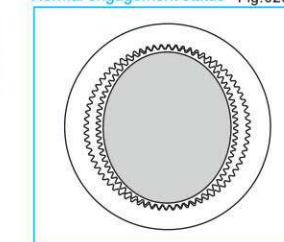

Deflection of the dial gauge Graph 029-3

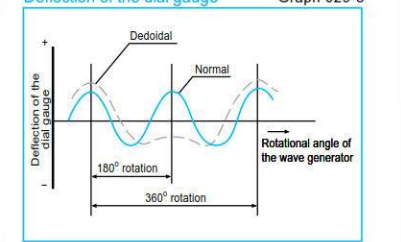

"Dedoidal" status Fig. 029-2

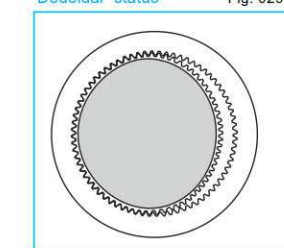

Measuring the deflection on the body of the flexspline Graph 029-4

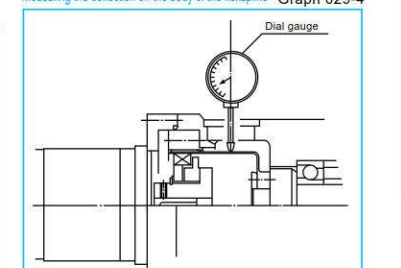

Checking Output Bearing

A precision cross roller bearing is built in the unit type and the gear head type to directly support the external load (output flange) (precision 4-point contact ball bearing for the CSF-mini series).

Please calculate maximum moment load, life of cross roller bearing, and static safety factor to fully maximize the performance of a housed unit (gearhead).

- See the corresponding pages on each series for main bearing specifications.

Checking procedure

(1) Checking the maximum moment load (Mmax)

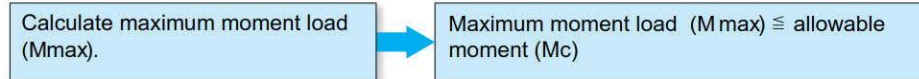

(2) Checking the life

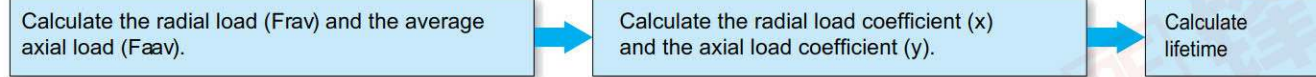

(3) Checking the static safety coefficient



How to calculate the maximum moment load

Maximum moment load (Mmax) is obtained as follows. Make sure that Mmax ≤ Mc.

Formula 030-1

$$M_{max} = F_{rmax} (L_r + R) + F_{amax} \cdot L_a$$

Symbols for Formula 030-1

Table 030-1

F _{rmax}	Max. radial load	N(kgf)	See Fig. 030-1.
F _{amax}	Max. axial load	N(kgf)	See Fig. 030-1.
L _r , L _a	—	m	See Fig. 030-1.
R	Offset amount	m	See Fig. 030-1 and "Specification of the output bearing" of each series.

External load influence diagram

Fig. 030-1

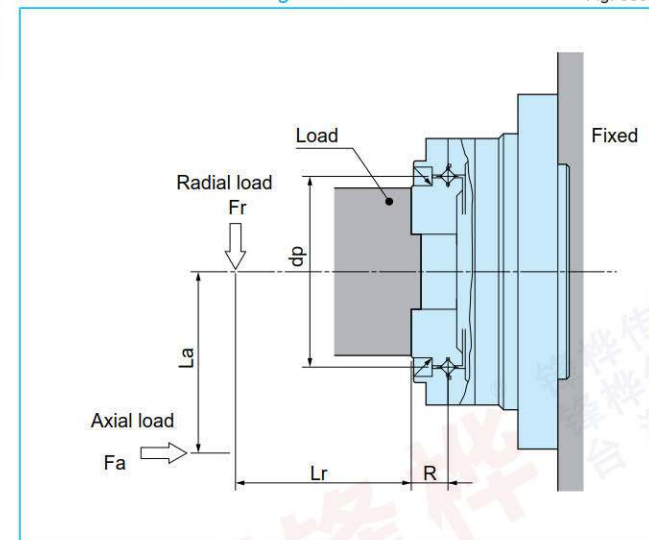

How to calculate the average load

(Average radial load, average axial load, average output speed)

When the radial load and axial load vary, the life of cross roller bearing can be determined by converting to an average load.

How to calculate the average radial load (Frav)

Formula 031-1

(Cross roller bearing)

$$F_{rav} = \sqrt[10/3]{\frac{n_1 t_1 (|F_{r1}|)^{10/3} + n_2 t_2 (|F_{r2}|)^{10/3} + \dots + n_n t_n (|F_{rn}|)^{10/3}}{n_1 t_1 + n_2 t_2 + \dots + n_n t_n}}$$

(4-point contact ball bearing)

$$F_{rav} = \sqrt[3]{\frac{n_1 t_1 (|F_{r1}|)^3 + n_2 t_2 (|F_{r2}|)^3 + \dots + n_n t_n (|F_{rn}|)^3}{n_1 t_1 + n_2 t_2 + \dots + n_n t_n}}$$

Note that the maximum radial load in t₁ is Fr₁ and the maximum radial load in t₃ is Fr₃.

How to calculate the average axial load (Faav)

Formula 031-2

(Cross roller bearing)

$$F_{aav} = \sqrt[10/3]{\frac{n_1 t_1 (|F_{a1}|)^{10/3} + n_2 t_2 (|F_{a2}|)^{10/3} + \dots + n_n t_n (|F_{an}|)^{10/3}}{n_1 t_1 + n_2 t_2 + \dots + n_n t_n}}$$

(4-point contact ball bearing)

$$F_{aav} = \sqrt[3]{\frac{n_1 t_1 (|F_{a1}|)^3 + n_2 t_2 (|F_{a2}|)^3 + \dots + n_n t_n (|F_{an}|)^3}{n_1 t_1 + n_2 t_2 + \dots + n_n t_n}}$$

Note that the maximum axial load in t₁ is Fa₁ and the maximum axial load in t₃ is Fa₃.

How to calculate the average output speed (Nav)

Formula 031-3

$$N_{av} = \frac{n_1 t_1 + n_2 t_2 + \dots + n_n t_n}{t_1 + t_2 + \dots + t_n}$$

How to calculate the radial load coefficient (X) and axial load coefficient (Y)

Formula 031-4

How to calculate the load coefficient	X	Y
$\frac{F_{aav}}{F_{rav} + 2(F_{rav}(L_r + R) + F_{aav} \cdot L_a) / dp} \leq 1.5$	1	0.45
$\frac{F_{aav}}{F_{rav} + 2(F_{rav}(L_r + R) + F_{aav} \cdot L_a) / dp} > 1.5$	0.67	0.67

Symbols for Formula 031-4

Table 031-1

F _{rav}	Average radial load	N(kgf)	See "How to calculate the average load." See Formula 031-1.
F _{aav}	Average axial load	N(kgf)	See "How to calculate the average load." See Formula 031-2.
L _r , L _a	—	m	See fig. 030-1
R	Offset amount	m	See Fig. 030-1 and "Main roller bearing specifications" of each series
dp	Pitch circle diameter of a roller	m	See Fig. 030-1 and "Specification of the output bearing" of each series.

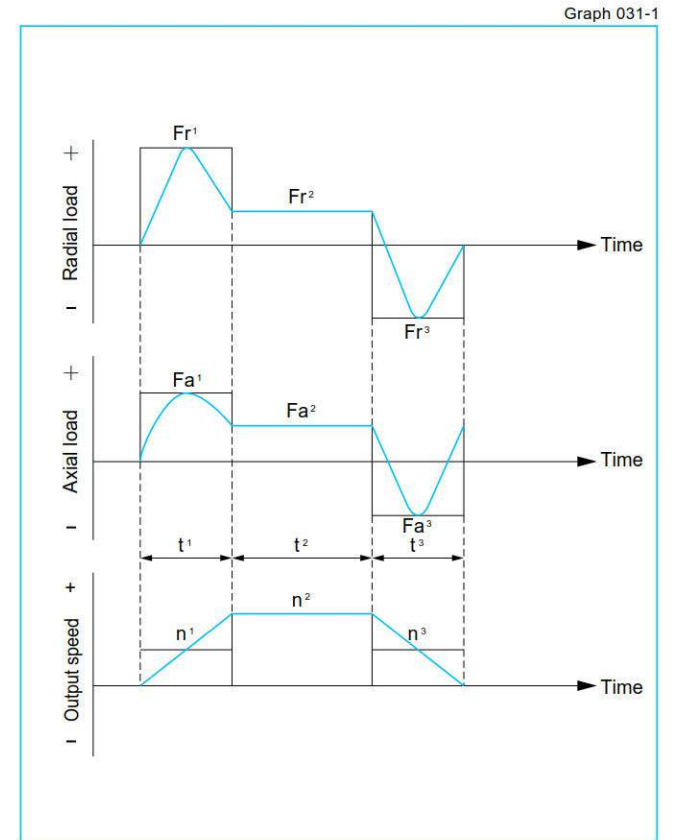

Life of the output bearing

Calculate life of the output bearing by Formula 032-1.
You can calculate the dynamic equivalent radial load (Pc) by Formula 032-2.

Formula 032-1

(Cross roller bearing)

$$L_{10} = \frac{10^6}{60 \times N_{av}} \times \left(\frac{C}{f_w \cdot P_c} \right)^{10/3}$$
 (4-point contact ball bearing)

$$L_{10} = \frac{10^6}{60 \times N_{av}} \times \left(\frac{C}{f_w \cdot P_c} \right)^3$$

Symbols for Formula 032-1

L ₁₀	Life	hour	—
N _{av}	Average output rated load speed	rpm	See "How to calculate the average load."
C	Basic dynamic rated load	N(kgf)	See "Specification of the output bearing" of each series.
P _c	Dynamic equivalent	N(kgf)	See Formula 032-2.
f _w	Load coefficient	—	See Table 032-3.

Load coefficient

Load status	f _w
Steady operation without impact and vibration	1 to 1.2
Normal operation	1.2 to 1.5
Operation with impact and vibration	1.5 to 3

How to calculate life during oscillating motion

Calculate the life of the cross roller bearing during oscillating motion by Formula 033-1.

Formula 033-1

(Cross roller bearing)

$$Loc = \frac{10^6}{60 \times n_1} \times \frac{90}{\theta} \times \left(\frac{C}{f_w \cdot P_c} \right)^{10/3}$$
 (4-point contact ball bearing)

$$Loc = \frac{10^6}{60 \times n_1} \times \frac{90}{\theta} \times \left(\frac{C}{f_w \cdot P_c} \right)^3$$

Symbols for Formula 033-1

Loc	Rated life for oscillating motion	hour	—
n ₁	Round trip oscillation each minute	cpm	—
C	Basic dynamic rated load	N(kgf)	—
P _c	Dynamic equivalent radial load	N(kgf)	See Formula 032-2.
f _w	Load coefficient	—	See Table 032-3.
θ	Oscillating angle / 2	Degree	See Fig. 033-1.

Formula 032-2

$$P_c = X \cdot \left(F_{rav} + \frac{2(F_{rav}(L+R) + F_{av} \cdot La)}{dp} \right) + Y \cdot F_{aav}$$

Symbols for Formula 032-2

F _{rav}	Average radial load	N(kgf)	See "How to calculate the average load." See Formula 031-1.
F _{aav} <td>Average axial load</td> <td>N(kgf)</td> <td>See "How to calculate the average load." See Formula 031-2.</td>	Average axial load	N(kgf)	See "How to calculate the average load." See Formula 031-2.
dp	Pitch circle diameter	m	See Fig. 030-1 and "Specification of the output bearing" of each series.
X	Radial load coefficient	—	See Formula 031-4.
Y	Axial load coefficient	—	See Formula 031-4.
L _r , L _a	—	m	See Figure 030-1.
R	Offset	m	See Fig. 030-1 and "Specification of the output bearing" of each series.
M _{ave}	Average moment load	Nm	—

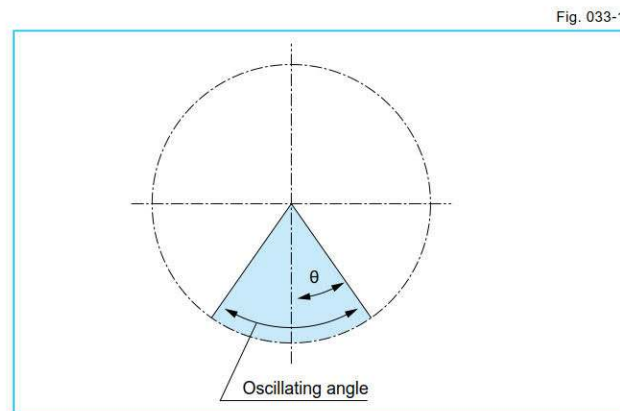

(Note) A small angle of oscillation (less than 5 degrees) may cause fretting corrosion to occur since lubrication may not circulate properly. Contact us if this happens.

How to calculate the static safety coefficient

Basic static rated load is an allowable limit for static load, but its limit is determined by usage. In this case, static safety coefficient of the cross roller bearing can be calculated by Formula 034-2.

Formula 034-1

$$f_s = \frac{C_o}{P_o}$$

Symbols for Formula 034-1

C _o	Basic static rated load	N(kgf)	See "Specification of the output bearing" of each series.
P _o	Static equivalent radial load	N(kgf)	See Formula 034-2.

Static Safety Coefficient

Operating condition of the roller bearing	f _s
When high rotation precision is required	≧ 3
When shock and vibration are expected	≧ 2
Under normal operating condition	≧ 1.5

Formula 034-2

$$P_o = F_{rmax} + \frac{2M_{max}}{dp} + 0.44F_{amax}$$

Symbols for Formula 034-2

F _{rmax}	Max. radial load	N(kgf)	See "How to calculate the maximum moment load" on Page 030.
F _{amax}	Max. axial load	N(kgf)	
M _{max}	Max. moment load	Nm(kgfm)	
dp	Pitch circle diameter of a roller	m	See Fig. 030-1 and "Specification of the output bearing" of each series.

Features



CSG/CSF Gear Unit

CSF/CSG are housed component gear sets combined with a precision cross roller output bearing & flange. A highly rigid cross roller bearing is built in to directly support (output bearing) the external load. They are a very compact, robust and easy to use gearhead solution. CSF and CSG are also available in lightweight versions.

Features

- Zero backlash
- Compact design
- High-torque capacity
- High stiffness
- High-positional and rotational accuracies

Structure of CSG/CSF series gear unit

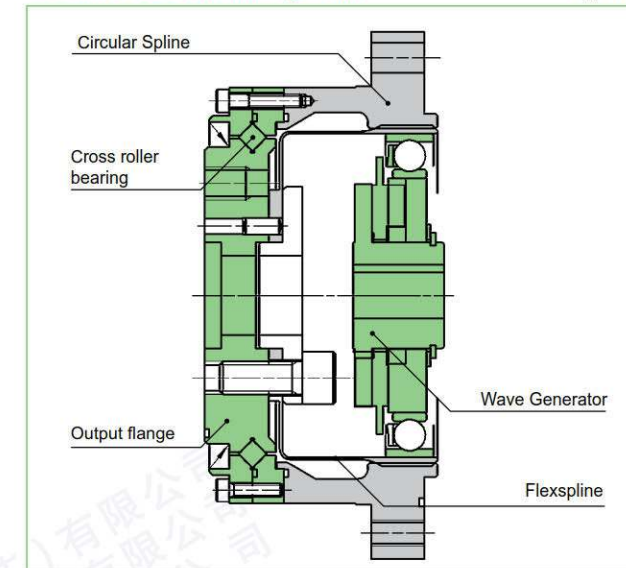

CSF v. CSG

- CSG high torque
- 30% Higher torque than CSF series.
 - The life has been improved by 43% (10,000 hours) compared to CSF.
- CSF: standard torque
- Reduction ratio of 30:1 included for high-speed
- CSF/CSG-LW series: Lightweight (sizes 14 to 45)
- 30% average lower weight than Standard Series.
 - Same performance as CSF/CSG series.

Main markets

Industrial robot

Various mechanical equipment

Vertical multi-joint robot

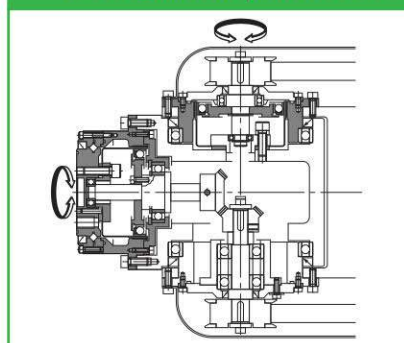

垂直多关节机器人手腕的弯曲、扭转驱动

※按照本组装机使用时，必须使用防止润滑油泄漏的密封机构。

Horizontal multi-joint robot

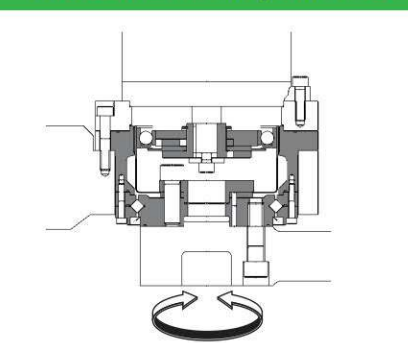

水平多关节机器人的机械臂驱动

※按照本组装机使用时，必须使用防止润滑油泄漏的密封机构。

Example of direct-connected servo motor

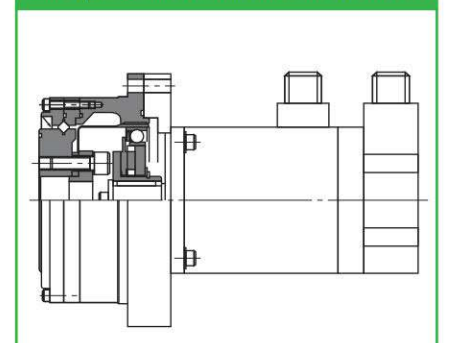

Ordering Code

CSG - 25 - 100 - 2UH - SP

Series	Size	Ratio ^{*1}						Model	Special specification
CSG	14	50	80	100	—	—	2A= Component type 2UH= Unit type 2UJ = Unit type with input shaft ^{*2}	LW= Lightweight SP= Special specification code Blank= Standard product	
	17	50	80	100	120	—			
	20	50	80	100	120	160			
	25	50	80	100	120	160			
	32	50	80	100	120	160			
	40	50	80	100	120	160			
	45	50	80	100	120	160			
	50	—	80	100	120	160			
	58	—	80	100	120	160			
	65	—	80	100	120	160			

*1 The reduction ratio value is based on the following configuration:
Input: wave generator, fixed: circular spline, output: flexspline

*2 Contact us for details.

Rating table

CSG Series

Size	Ratio	Rated Torque at 2000rpm		Limit for Repeated Peak Torque		Limit for Average Torque		Limit for Momentary Peak Torque		Maximum Input Speed (rpm)		Limit for Average Input Speed (rpm)		Moment of Inertia								
		Nm	kgfm	Nm	kgfm	Nm	kgfm	Nm	kgfm	Oil lubricant	Grease lubricant	Oil lubricant	Grease lubricant	I ×10 ⁻⁴ kgm ²	J ×10 ⁻⁴ kgfms ²							
		14	50	7.0	0.7	23	2.3	9	0.9	46	4.7	14000	8500	6500	3500	0.033	0.034					
14	80	10	1.0	30	3.1	14	1.4	58 ^{*3}	5.9 ^{*3}	14000	8500	6500	3500	0.033	0.034							
	100	10	1.0	36	3.7	14	1.4	58 ^{*3}	5.9 ^{*3}													
	17	50	21	2.1	44	4.5	34	3.4	91							9	10000	7300	6500	3500	0.079	0.081
17	80	29	2.9	56	5.7	35	3.6	109 ^{*3}	11 ^{*3}													
	100	31	3.2	70	7.2	51	5.2	109 ^{*3}	11 ^{*3}													
	120	31	3.2	70	7.2	51	5.2	109 ^{*3}	11 ^{*3}	10000	6500	3500	0.193	0.197								
20	50	33	3.3	73	7.4	44	4.5	127	13													
	80	44	4.5	96	9.8	61	6.2	165	17													
	100	52	5.3	107	10.9	64	6.5	191	20													
20	120	52	5.3	113	11.5	64	6.5	191	20	10000	6500	6500	3500	0.193	0.197							
	160	52	5.3	120	12.2	64	6.5	191	20													
	25	50	51	5.2	127	13	72	7.3	242							25	7500	5600	5600	3500	0.413	0.421
25	80	82	8.4	178	18	113	12	332	34													
	100	87	8.9	204	21	140	14	369	38													
	25	120	87	8.9	217	22	140	14	*4	*4	7500	5600	5600	3500	0.413	0.421						
160		87	8.9	229	23	140	14	*4	*4													
32		50	99	10	281	29	140	14	497	51							7000	4800	4600	3500	1.69	1.72
32	80	153	16	395	40	217	22	738	75													
	100	178	18	433	44	281	29	841	86													
	32	120	178	18	459	47	281	29	892	91	7000	4800	4600	3500	1.69	1.72						
160		178	18	484	49	281	29	892	91													
40		50	178	18	523	53	255	26	892	91							5600	4000	3600	3000	4.50	4.59
40	80	268	27	675	69	369	38	1270	130													
	100	345	35	738	75	484	49	1400	143													
	40	120	382	39	802	82	586	60	1510 ^{*4}	154 ^{*4}	5600	4000	3600	3000	4.50	4.59						
160		382	39	841	86	586	60	1510 ^{*4}	154 ^{*4}													
45		50	229	23	650	66	345	35	1235	126							5000	3800	3300	3000	8.68	8.86
45	80	407	41	918	94	507	52	1651	168													
	100	459	47	982	100	650	66	2041	208													
	45	120	523	53	1070	109	806	82	2288	233	5000	3800	3300	3000	8.68	8.86						
160		523	53	1147	117	819	84	2483	253													
50		80	484	49	1223	125	675	69	2418	247							4500	3500	3000	2500	12.5	12.8
50	100	611	62	1274	130	866	88	2678	273													
	120	688	70	1404	143	1057	108	2678	273													
	50	160	688	70	1534	156	1096	112	3185	325	4500	3500	3000	2500	12.5	12.8						
58		80	714	73	1924	196	1001	102	3185	325							4000	3000	2700	2200	27.3	27.9
58		100	905	92	2067	211	1378	141	4134	422												
	120	969	99	2236	228	1547	158	4329	441	4000	3000	2700	2200	27.3	27.9							
	58	160	969	99	2392	244	1573	160	4459							455						
65		80	969	99	2743	280	1352	138	4836							493	3500	2800	2400	1900	46.8	47.8
65		100	1236	126	2990	305	1976	202	6175	630												
	120	1236	126	3263	333	2041	208	6175	630													
	160	1236	126	3419	349	2041	208	6175	630													

(Note) 1. Moment of inertia: $I = \frac{1}{4} GD^2$

2. See "Engineering data" on Page 12 for details of the terms.

3. The value of allowable max momentary torque is limited by the transmission torque of the unit. (See table 138-1, 2 on p.138.)

4. When using LW series, see the transmission torque of the unit (Table 138-3, 4 on p.138) for the allowable maximum momentary torque.

Ordering Code

CSF - 25 - 100 - 2UH - SP

Series	Size	Ratio ^{*1}						Model	Special specification
CSF	14	30	50	80	100	—	—	2A= Component type 2UH= Unit type 2UJ = Unit type with input shaft ^{*2}	LW= Lightweight (sizes 14 to 45) SP= Special specification code Blank= Standard product
	17	30	50	80	100	120	—		
	20	30	50	80	100	120	160		
	25	30	50	80	100	120	160		
	32	30	50	80	100	120	160		
	40	—	50	80	100	120	160		
	45	—	50	80	100	120	160		
	50	—	50	80	100	120	160		
	58	—	50	80	100	120	160		
	65	—	50	80	100	120	160		

*1 The reduction ratio value is based on the following configuration:
Input: wave generator, fixed: circular spline, output: flexspline

*2 Contact us for details.

Rating table

CSF Series

Size	Ratio	Rated Torque at 2000rpm		Limit for Repeated Peak Torque		Limit for Average Torque		Limit for Momentary Peak Torque		Maximum Input Speed (rpm)		Limit for Average Input Speed (rpm)		Moment of Inertia								
		Nm	kgfm	Nm	kgfm	Nm	kgfm	Nm	kgfm	Oil lubricant	Grease lubricant	Oil lubricant	Grease lubricant	I ×10 ⁻⁴ kgm ²	J ×10 ⁻⁴ kgfms ²							
		14	30	4.0	0.41	9.0	0.92	6.8	0.69	17	1.7	14000	8500	6500	3500	0.033	0.034					
50	5.4		0.55	18	1.8	6.9	0.70	35	3.6													
80	7.8		0.80	23	2.4	11	1.1	47	4.8													
100	7.8		0.80	28	2.9	11	1.1	54	5.5													
17	30	8.8	0.90	16	1.6	12	1.2	30	3.1	10000	7300	6500	3500	0.079	0.081							
	50	16	1.6	34	3.5	26	2.6	70	7.1													
	80	22	2.2	43	4.4	27	2.7	87	8.9													
	100	24	2.4	54	5.5	39	4.0	108	11													
17	120	24	2.4	54	5.5	39	4.0	86	8.8	10000	6500	6500	3500	0.193	0.197							
	20	50	15	1.5	27	2.8	20	2.0	50							5.1						
	80	25	2.5	56	5.7	34	3.5	98	10													
	100	34	3.5	74	7.5	47	4.8	127	13													
20	120	40	4.1	82	8.4	49	5.0	147	15	10000	6500	6500	3500	0.193	0.197							
	160	40	4.1	87	8.9	49	5.0	147	15													
	25	30	27	2.8	50	5.1	38	3.9	95							9.7	7500	5600	5600	3500	0.413	0.421
	80	39	4.0	98	10	55	5.6	186	19													
100	63	6.4	137	14	87	8.9	255	26														
120	67	6.8	157	16	108	11	284	29														
25	160	67	6.8	167	17	108	11	304	31	7500	5600	5600	3500	0.413	0.421							
	32	30	54	5.5	100	10	75	7.7	200							20						
	50	76	7.8	216	22	108	11	382	39													
	80	118	12	304	31	167	17	568	58													
32	100	137	14	333	34	216	22	647	66	7000	4800	4600	3500	1.69	1.72							
	120	137	14	353	36	216	22	686	70													
	160	137	14	372	38	216	22	686	70													
	40	50	137	14	402	41	196	20	686							70	5600	4000	3600	3000	4.50	4.59
80	206	21	519	53	284	29	980	100														
100	265	27	568	58	372	38	1080	110														
120	294	30	617	63	451	46	1180	120														
40	160	294	30	647	66	451	46	1180	120	5600	4000	3600	3000	4.50	4.59							
	45	50	176	18	500	51	265	27	950							97						
	80	313	32	706	72	390	40	1270	130													
	100	353	36	755	77	500	51	1570	160													
45	120	402	41	823	84	620	63	1760	180													

Outline Dimensions

You can download the CAD files from our website: harmonicdrive.net



Fig. 128-1

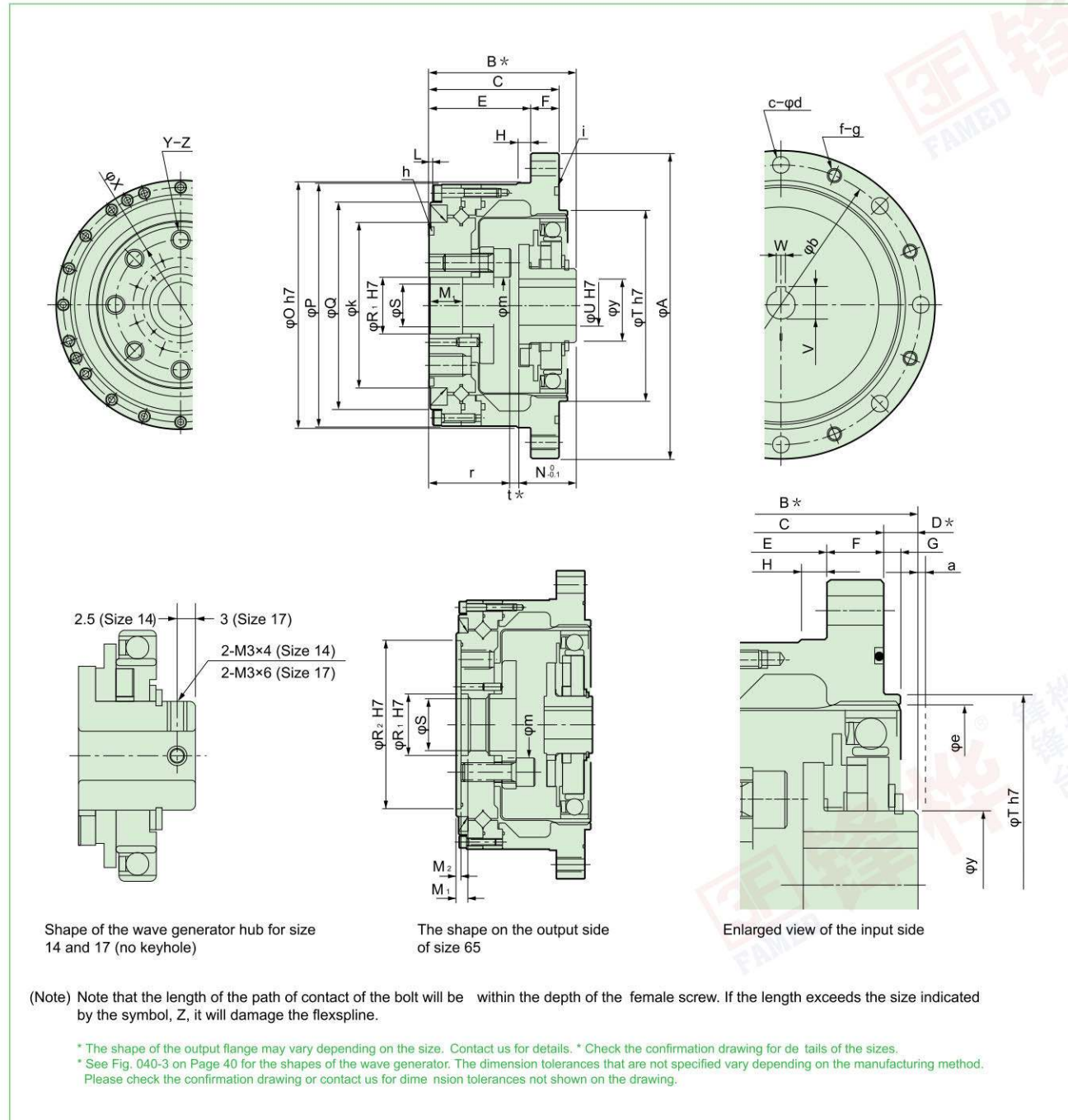

Dimensions

Table 129-1
Unit: mm

Symbol	Size	14	17	20	25	32	40	45	50	58	65
ϕA		73	79	93	107	138	160	180	190	226	260
B^*		41 ⁰ _{-0.9}	45 ⁰ _{-0.9}	45.5 ⁰ _{-1.0}	52 ⁰ _{-1.0}	62 ⁰ _{-1.1}	72.5 ⁰ _{-1.1}	79.5 ⁰ _{-1.2}	90 ⁰ _{-1.3}	104.5 ⁰ _{-1.3}	115 ⁰ _{-1.3}
C		34	37	38	46	57	66.5	74	85	97	108.5
D*	CSG Series	7 ⁰ _{-0.4}	8 ⁰ _{-0.4}	7.5 ⁰ _{-0.4}	6 ⁰ _{-0.5}	5 ⁰ _{-0.6}	6 ⁰ _{-0.6}	5.5 ⁰ _{-0.6}	5 ⁰ _{-0.6}	7.5 ⁰ _{-0.6}	6.5 ⁰ _{-0.6}
	CSG-LW Series										
	CSF Series	7 ⁰ _{-0.8}	8 ⁰ _{-0.9}	7.5 ⁰ _{-1.0}	6 ⁰ _{-1.0}	5 ⁰ _{-1.1}	6 ⁰ _{-1.1}	5.5 ⁰ _{-1.2}	5 ⁰ _{-1.3}	7.5 ⁰ _{-1.3}	6.5 ⁰ _{-1.3}
	CSF-LW Series										
E		27	29	28	36	45	50.5	58	69	77	84.5
F		7	8	10	10	12	16	16	16	20	24
G		2	2	3	3	3	4	4	4	5	5
H	CSG Series	3.5	4	5	5	5	6	6	6	6	6
	CSG-LW Series	4	4	5	5	4.5	4.5	6	6	6	6
	CSF Series	3.5	4	5	5	5	6	6	6	6	6
	CSF-LW Series	4	4	5	5	4.5	4.5	6	6	6	6
L	CSG Series	0.5	0.5	0.5	0.5	1	1.5	1	1	1.5	1.5
	CSG-LW Series	1.1	1.1	1.1	1.1	1.2	1.6	1.6	1	1.5	1.5
	CSF Series	0.5	1.1	1.1	1.1	1.2	1.6	1.6	1	1.5	1.5
	CSF-LW Series	1.1	1.1	1.1	1.1	1.2	1.6	1.6	1	1.5	1.5
M1		9.4	9.5	9	2	15	5	6	8	10	10
M2		-	-	-	-	-	-	-	-	-	4
N _{0.1}	CSG Series	18.5	20.7	21.5	21.6	23.6	29.7	30.5	34.8	38.3	44.6
	CSG-LW Series										
	CSF Series	17.6	19.5	20.1	20.2	22	27.5	27.9	32	34.9	40.9
	CSF-LW Series										
ϕO h7		56	63	72	86	113	127	148	158	186	212
ϕP	CSG Series	56	62	70	85	112	123	147	157	185	210
	CSG-LW Series	54.6	61.6	69.6	85	110	124.5	143	155	183.4	208.4
	CSF Series	55	62	70	85	112	123	147	157	185	210
	CSF-LW Series	54.6	61.6	69.6	85	110	124.5	143	155	183.4	208.4
ϕQ	CSG Series	42.5	49.5	58	73	96	109	127	137	161	186
	CSG-LW Series	40.5	47.5	55.5	71	91.1	103	123	130	155	180
	CSF Series	42.5	49.5	58	73	96	109	127	137	161	186
	CSF-LW Series	40.5	47.5	55.5	71	91.1	103	123	130	155	180
$\phi R1$ H7		11	10	14	20	26	32	32	40	46	52
$\phi R2$ H7		-	-	-	-	-	-	-	-	-	142
ϕS		8	7	10	15	20	24	25	32	38	44
ϕT h7		38	48	56	67(68)	90	110	124	135	156	177
ϕU H7		6	8	12	14	14	14	19	19	22	24
V		-	-	13.8 ^{+0.1} ₀	16.3 ^{+0.1} ₀	16.3 ^{+0.1} ₀	16.3 ^{+0.1} ₀	21.8 ^{+0.1} ₀	21.8 ^{+0.1} ₀	24.8 ^{+0.1} ₀	27.3 ^{+0.2} ₀
W Js9		-	-	4	5	5	5	6	6	6	8
ϕX		23	27	32	42	55	68	82	84	100	110
Y		6	6	8	8	8	8	8	8	8	8
Z		M4×8	M5×10	M6×9	M8×12	M10×15	M10×15	M12×18	M14×21	M16×24	M16×24
a		1	1	1.5	1.5	1.5	2	2	2	2.5	2.5
ϕb		65	71	82	96	125	144	164	174	206	236
c	CSG Series	8	8	8	10	12	10	12	14	12	8
	CSG-LW Series	6	8	8	10	12	10	16	18	16	12
	CSF Series	6	6	6	8	12	8	12	12	12	8
	CSF-LW Series	6	8	8	10	12	10	16	18	16	12
ϕd		4.5	4.5	5.5	5.5	6.6	9	9	9	11	14
ϕe		38	45	53	66	86	106	119	133	154	172
f	CSG Series	8	8	8	10	12	10	12	14	12	8
	CSG-LW Series	6	8	8	10	12	10	16	18	16	12
	CSF Series	6	6	6	8	12	8	12	12	12	8
	CSF-LW Series	6	8	8	10	12	10	16	18	16	12
g		M4	M4	M5	M5	M6	M8	M8	M8	M10	M12
h		29.0×0.50	34.5×0.80	40.64×1.14	53.28×0.99	S71	AS568-042	S100	S105	S125	S135
i		S50	S56	S67	S80	S105	S125	S145	S155	S180	S205
ϕk		31	38	45	58	78	90	107	112	135	155
ϕm		10	10.5	15.5	20	27	34	36	39	46	56
r		21.4	23.5	23	29	37	39.5	45.5	53	62.8	66.5
t*	CSG Series	1.1	0.8	1	1.4	1.4	3.3	3.5	2.2	3.4	3.9
	CSG-LW Series										
	CSF Series	2	2	2.4	2.8	3	5.5	6.1	5	6.8	7.6
	CSF-LW Series										
ϕy		14	18	21	26	26	32	32	32	40	48
Mass (kg)	CSG Series	0.52	0.68	0.98	1.5	3.2	5.0	7.0	8.9	14.6	20.9
	CSG-LW Series	0.32	0.46	0.64	1.1	2.2	3.5	5.1	7	11.3	16.2
	CSF Series	0.52	0.68	0.98	1.5	3.2	5.0	7.0	8.9	14.6	20.9
	CSF-LW Series	0.32	0.46	0.64	1.1	2.2	3.5	5.1	7	11.3	16.2

(note1) the dimension in parenthesis is for reduction ratio 30.

● The B, D, and t values indicate relative position of individual gearing components (wave generator, flexspline, circular spline). Please strictly adhere to these values when designing your housing and mating parts.

● Wave generator is removed when the product is delivered.
 ● CSF & CSG-LW available in sizes 14 to 45.

Positioning accuracy

See "Engineering data" for a description of terms.

Table 150-1
Unit: X10⁻⁴rad (arc·min)

Ratio	Specification	14	17	20	25	32	40 to 65
30	Standard product	5.8	4.4	4.4	4.4	4.4	—
		(2)	(1.5)	(1.5)	(1.5)	(1.5)	—
	Special product	—	—	2.9	2.9	2.9	—
50 or more	Standard product	4.4	4.4	2.9	2.9	2.9	2.9
		(1.5)	(1.5)	(1)	(1)	(1)	(1)
	Special product	2.9	2.9	1.5	1.5	1.5	1.5
		(1)	(1)	(0.5)	(0.5)	(0.5)	(0.5)

Hysteresis loss

See "Engineering data" for a description of terms.

Table 150-2

Ratio	Size	14	17	20	25	32	40 or more
30	×10 ⁻⁴ rad	8.7	8.7	8.7	8.7	8.7	—
	arc min	3.0	3.0	3.0	3.0	3.0	—
50	×10 ⁻⁴ rad	5.8	5.8	5.8	5.8	5.8	5.8
	arc min	2.0	2.0	2.0	2.0	2.0	2.0
80 or more	×10 ⁻⁴ rad	2.9	2.9	2.9	2.9	2.9	2.9
	arc min	1.0	1.0	1.0	1.0	1.0	1.0

Max. backlash quantity

See "Engineering data" for a description of terms.

Table 150-3

Ratio	Size	14	17	20	25	32	40	45	50	58	65
30	×10 ⁻⁴ rad	29.1	16.0	13.6	13.6	11.2	—	—	—	—	—
	arc sec	60	33	28	28	23	—	—	—	—	—
50	×10 ⁻⁴ rad	17.5	9.7	8.2	8.2	6.8	6.8	5.8	5.8	4.8	4.8
	arc sec	36	20	17	17	14	14	12	12	10	10
80	×10 ⁻⁴ rad	11.2	6.3	5.3	5.3	4.4	4.4	3.9	3.9	2.9	2.9
	arc sec	23	13	11	11	9	9	8	8	6	6
100	×10 ⁻⁴ rad	8.7	4.8	4.4	4.4	3.4	3.4	2.9	2.9	2.4	2.4
	arc sec	18	10	9	9	7	7	6	6	5	5
120	×10 ⁻⁴ rad	—	3.9	3.9	3.9	2.9	2.9	2.4	2.4	1.9	1.9
	arc sec	—	8	8	8	6	6	5	5	4	4
160	×10 ⁻⁴ rad	—	—	2.9	2.9	2.4	2.4	1.9	1.9	1.5	1.5
	arc sec	—	—	6	6	5	5	4	4	3	3

Torsional Stiffness

See "Engineering data" for a description of terms.

Table 150-4

Symbol	Size	14	17	20	25	32	40	45	50	58	65		
T ₁	Nm	2.0	3.9	7.0	14	29	54	76	108	168	235		
	kgfm	0.20	0.40	0.70	1.4	3.0	5.5	7.8	11	17	24		
T ₂	Nm	6.9	12	25	48	108	196	275	382	598	843		
	kgfm	0.7	1.2	2.5	4.9	11	20	28	39	61	86		
Reduction ratio 30	K ₁	×10 ⁴ Nm/rad	0.19	0.34	0.57	1.0	2.4	—	—	—	—	—	
		kgfm/arc min	0.056	0.10	0.17	0.30	0.70	—	—	—	—	—	
	K ₂	×10 ⁴ Nm/rad	0.24	0.44	0.71	1.3	3.0	—	—	—	—	—	
		kgfm/arc min	0.07	0.13	0.21	0.40	0.89	—	—	—	—	—	
	K ₃	×10 ⁴ Nm/rad	0.34	0.67	1.1	2.1	4.9	—	—	—	—	—	
		kgfm/arc min	0.10	0.20	0.32	0.62	1.5	—	—	—	—	—	
	θ	×10 ⁻⁴ rad	10.5	11.5	12.3	14	12.1	—	—	—	—	—	
		arc min	3.6	4.0	4.1	4.7	4.3	—	—	—	—	—	
	θ	×10 ⁻⁴ rad	31	30	38	40	38	—	—	—	—	—	
		arc min	10.7	10.2	12.7	13.4	13.3	—	—	—	—	—	
	Reduction ratio 50	K ₁	×10 ⁴ Nm/rad	0.34	0.81	1.3	2.5	5.4	10	15	20	31	44
			kgfm/arc min	0.1	0.24	0.38	0.74	1.6	3.0	4.3	5.9	9.3	13
K ₂		×10 ⁴ Nm/rad	0.47	1.1	1.8	3.4	7.8	14	20	28	44	61	
		kgfm/arc min	0.14	0.32	0.52	1.0	2.3	4.2	6.0	8.2	13	18	
K ₃		×10 ⁴ Nm/rad	0.57	1.3	2.3	4.4	9.8	18	26	34	54	78	
		kgfm/arc min	0.17	0.4	0.67	1.3	2.9	5.3	7.6	10	16	23	
θ		×10 ⁻⁴ rad	5.8	4.9	5.2	5.5	5.5	5.2	5.2	5.5	5.2	5.2	
		arc min	2.0	1.7	1.8	1.9	1.9	1.8	1.8	1.9	1.8	1.8	
θ		×10 ⁻⁴ rad	16	12	15.4	15.7	15.7	15.4	15.1	15.4	15.1	15.1	
		arc min	5.6	4.2	5.3	5.4	5.4	5.3	5.2	5.3	5.2	5.2	

* The values in this table are reference values. The minimum value is approximately 80% of the displayed value.

Table 151-1

Symbol	Size	14	17	20	25	32	40	45	50	58	65	
T ₁	Nm	2.0	3.9	7.0	14	29	54	76	108	168	235	
	kgfm	0.20	0.40	0.70	1.4	3.0	5.5	7.8	11	17	24	
T ₂	Nm	6.9	12	25	48	108	196	275	382	598	843	
	kgfm	0.7	1.2	2.5	4.9	11	20	28	39	61	86	
Reduction ratio 80 or more	K ₁	×10 ⁴ Nm/rad	0.47	1	1.6	3.1	6.7	13	18	25	40	54
		kgfm/arc min	0.14	0.3	0.47	0.92	2.0	3.8	5.4	7.4	12	16
	K ₂	×10 ⁴ Nm/rad	0.61	1.4	2.5	5.0	11	20	29	40	61	88
		kgfm/arc min	0.18	0.4	0.75	1.5	3.2	6.0	8.5	12	18	26
	K ₃	×10 ⁴ Nm/rad	0.71	1.6	2.9	5.7	12	23	33	44	71	98
		kgfm/arc min	0.21	0.46	0.85	1.7	3.7	6.8	9.7	13	21	29
	θ	×10 ⁻⁴ rad	4.1	3.9	4.4	4.4	4.4	4.1	4.1	4.4	4.1	4.4
		arc min	1.4	1.3	1.5	1.5	1.5	1.4	1.4	1.5	1.4	1.5
	θ	×10 ⁻⁴ rad	12	9.7	11.3	11.1	11.6	11.1	11.1	11.1	11.1	11.3
		arc min	4.2	3.3	3.9	3.8	4.0	3.8	3.8	3.8	3.8	3.9

* The values in this table are reference values. The minimum value is approximately 80% of the displayed value.

Starting torque

See "Engineering data" for a description of terms. As the values in the table below vary depending on the use conditions, use them as reference values.

Table 151-2
Unit: Ncm

Ratio	Size	14	17	20	25	32	40	45	50	58	65
50		4.5	6.7	8.6	17	34	61	85	—	—	—
80		3.1	4.4	5.4	10	21	39	54	73	108	154
100		2.8	3.7	4.7	8.8	20	34	47	64	97	132
120		—	3.4	4.2	8.0	17	31	43	57	88	121
160		—	—	3.6	6.9	15	26	36	50	75	102

CSF Series

Table 151-3
Unit: Ncm

Ratio	Size	14	17	20	25	32	40	45	50	58	65
30		6.4	9.3	15	25	54	—	—	—	—	—
50		4.1	6.1	7.8	15	31	55	77	110	160	220
80		2.8	4	4.9	9.2	19	35	49	66	98	140
100		2.5	3.4	4.3	8	18	31	43	58	88	120
120		—	3.1	3.8	7.3	15	28	39	52	80	110
160		—	—	3.3	6.3	14	24	33	45	68	93

Backdriving torque

See "Engineering data" for a description of terms. As the values in the table below vary depending on the use conditions, use them as reference values.

Table 151-4
Unit: N·m

Ratio	Size	14	17	20	25	32	40	45	50	58	65
50		1.8	3.3	5.2	9.9	20	36	52	—	—	—
80		1.8	3.3	5.3	10	21	36	53	69	106	154
100		2	3.6	5.6	11	22	40	56	75	121	165
120		—	3.9	6.1	12	24	43	61	80	121	176
160		—	—	7	14	29	51	70	94	143	198

CSF Series

Table 151-5
Unit: N·m

Ratio	Size	14	17	20	25	32	40	45	50	58	65
30		2.4	3.8	6.2	11	23	—	—	—	—	—
50		1.6	3	4.7	9	18	33	47	62	95	130
80		1.6	3	4.8	9.1	19	33	48	63	96	140
100		1.8	3.3	5.1	9.8	20	36	51	68	110	150
120		—	3.5	5.5	11	22	39	55	73	110	160
160		—	—	6.4	13	26	46	64	85	130	180

Ratcheting torque

See "Engineering data" for a description of terms.

CSG Series

Ratio \ Size	14	17	20	25	32	40	45	50	58	65
50	110	190	280	580	1200	2300	3500	—	—	—
80	140	260	450	880	1800	3600	5000	7000	10000	14000
100	100	200	330	650	1300	2700	4000	5300	8300	12000
120	—	150	310	610	1200	2400	3600	4900	7500	10000
160	—	—	280	580	1200	2300	3300	4600	7200	10000

Table 132-1
Unit: Nm

CSF Series

Ratio \ Size	14	17	20	25	32	40	45	50	58	65
30	59	100	170	340	720	—	—	—	—	—
50	88	150	220	450	980	1800	2700	3700	5800	7800
80	110	200	350	680	1400	2800	3900	5400	8200	11000
100	84	160	260	500	1000	2100	3100	4100	6400	9400
120	—	120	240	470	980	1900	2800	3800	5800	8300
160	—	—	220	450	980	1800	2600	3600	5600	8000

Table 132-2
Unit: Nm

Buckling torque

See "Engineering data" for a description of terms.

CSG Series

Size	14	17	20	25	32	40	45	50	58	65
Total reduction ratio	260	500	800	1700	3500	6700	8900	12200	19000	26600

Table 132-3
Unit: Nm

CSF Series

Size	14	17	20	25	32	40	45	50	58	65
Total reduction ratio	190	330	560	1000	2200	4300	5800	8000	12000	17000

Table 132-4
Unit: Nm

No-load running torque

No load running torque indicates the torque which is needed to rotate input of the gear, "Wave Generator", with no load on the output side (low speed side).

Measurement condition

Table 132-5

Ratio			
Lubricant	Grease lubrication	Name	Harmonic Grease SK-1A
		Quantity	Recommended quantity
Torque value is measured after 2 hours at 2000rpm input.			

* Contact us for oil lubrication.

Compensation value for no-load running torque

Table 132-6
Unit: Ncm

Ratio \ Size	30	50	80	120	160
14	2.5	1.1	0.2	—	—
17	3.8	1.6	0.3	-0.2	—
20	5.4	2.3	0.5	-0.3	-0.8
25	8.8	3.8	0.7	-0.5	-1.2
32	16	7.1	1.3	-0.9	-2.2
40	—	12	2.1	-1.5	-3.5
45	—	16	2.9	-2.1	-4.9
50	—	21	3.7	-2.6	-6.2
58	—	30	5.3	-3.8	-8.9
65	—	41	7.2	-5.1	-12

Compensation Value in Each Ratio

No-load running torque of the gear varies with ratio. The graphs indicate a value for ratio 100. For other gear ratios, add the compensation values from table on the right.

No-load running torque for a reduction ratio of 100:1

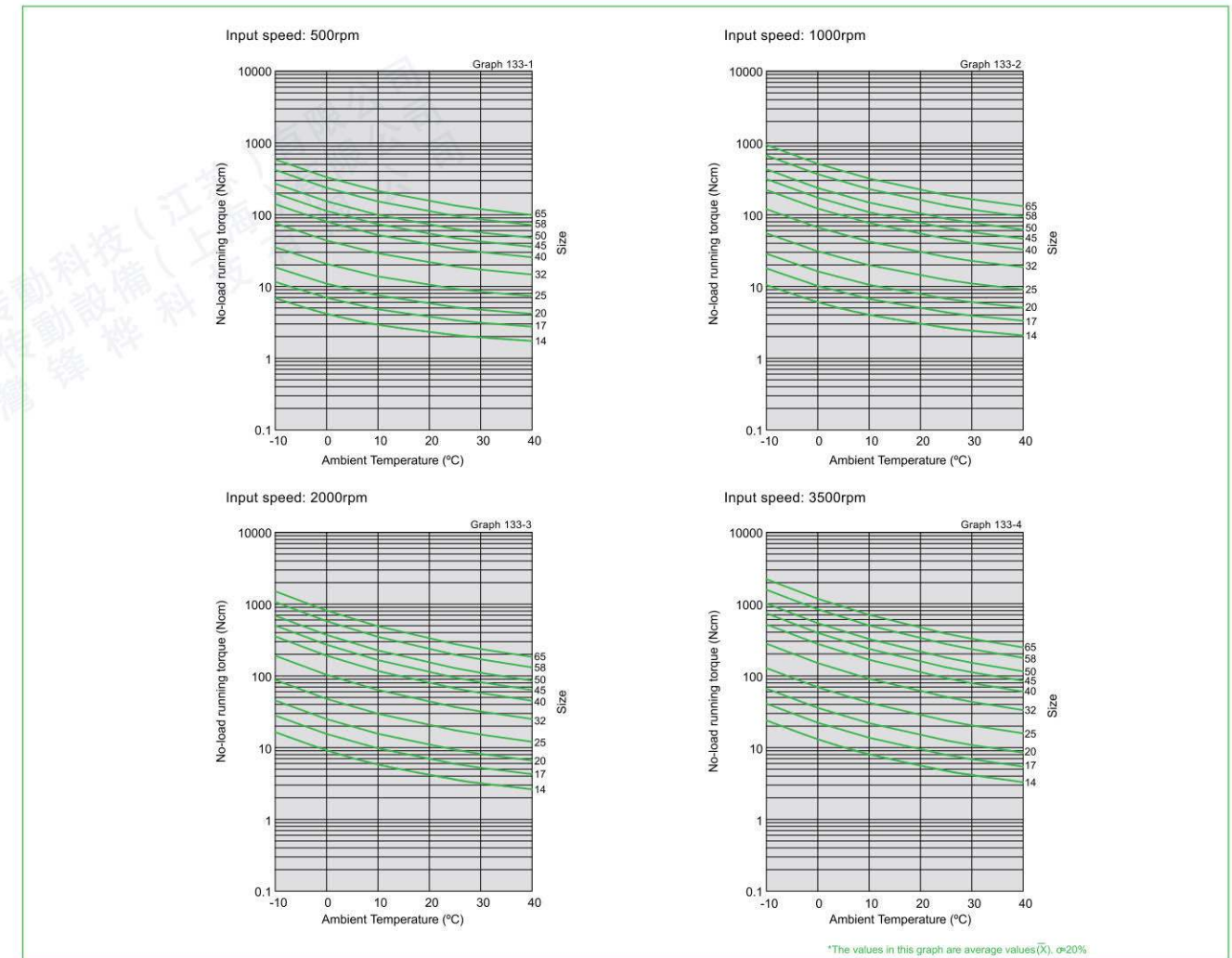

*The values in this graph are average values(X), σ=20%

Efficiency

The efficiency varies depending on the following conditions.

- Reduction ratio
- Input rotational speed
- Load torque
- Temperature
- Lubrication (Type and quantity)

Efficiency compensation coefficient

If the load torque is lower than the rated torque, the efficiency will be lower. Calculate the compensation coefficient K_e from Graph 134-1 to calculate the efficiency using the following example.

Calculation Example

Efficiency η (%) under the following condition is calculated from the example of CSF-20-80-2A-GR.
 Input rotational speed: 1000 rpm
 Load torque: 19.6 Nm
 Lubrication: Grease lubrication (Harmonic Grease SK-1A)
 Lubricant temperature: 20°C
 Since the rated torque of size 20 with a reduction ratio of 80 is 34 Nm (Ratings: Page 127), the torque ratio α is 0.58.
 ($\alpha = 19.6/34 = 0.58$)

- The efficiency compensation coefficient is $K_e = 0.93$ from Graph 134-1.
- Efficiency η at load torque 19.6 Nm: $\eta = K_e \cdot \eta_R = 0.93 \times 78 = 73\%$

Measurement condition

Table 134-1

Installation	Based on recommended tolerance.		
Load torque	The rated torque shown in the rating table (see page 126 and 127)		
Lubricant	Grease lubrication	Name	Harmonic Grease SK-1A
		Quantity	Recommended quantity

Efficiency compensation coefficient

Graph 134-1

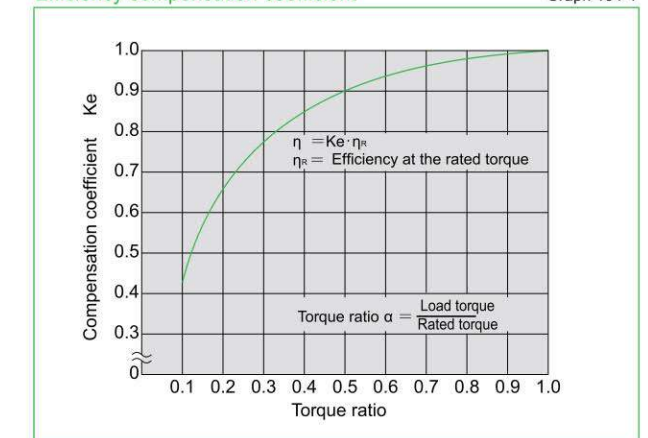

* Efficiency compensation coefficient $K_e = 1$ holds when the load torque is greater than the rated torque.

■ Efficiency at rated torque (Size 14)

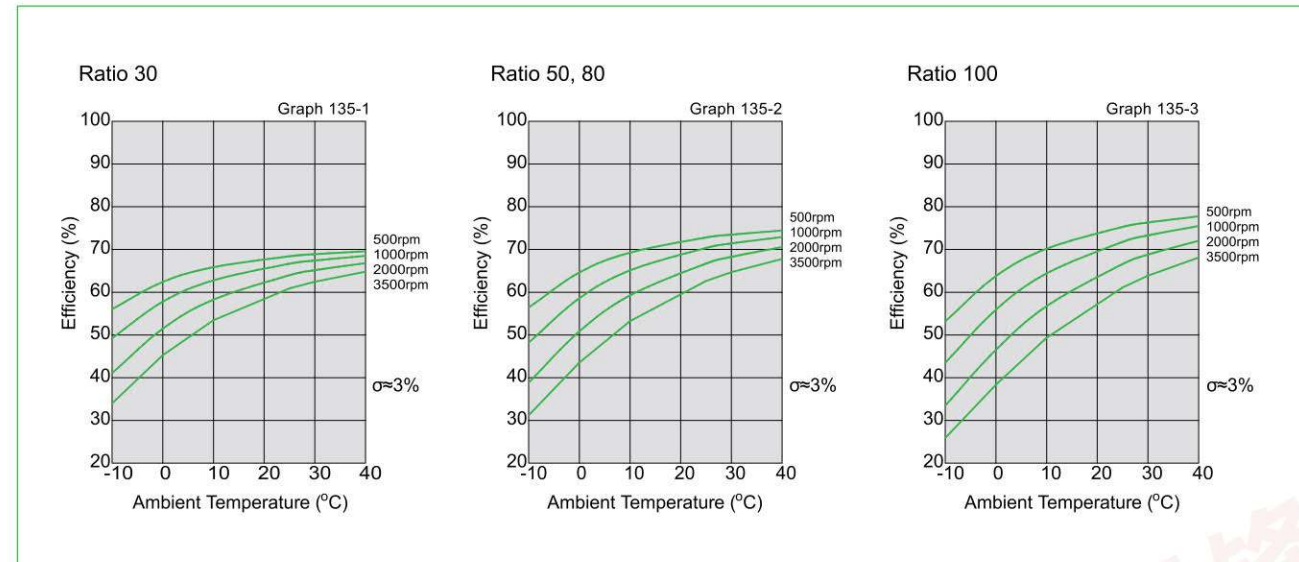

■ Efficiency at rated torque (Sizes 17 to 65)

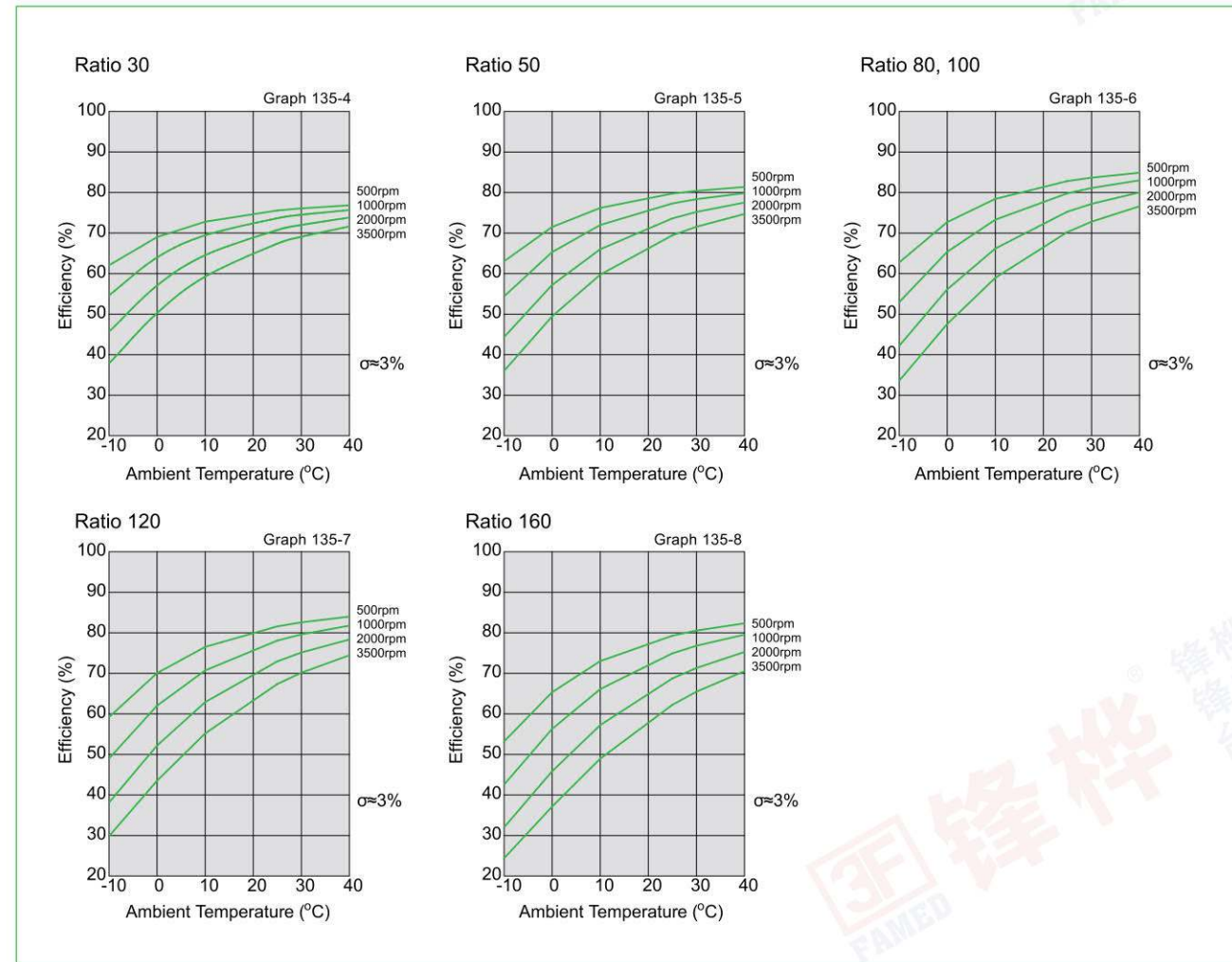

Checking output bearing

A precision cross roller bearing is built in the unit type to directly support the external load (output flange). Check the maximum moment load, life of the bearing and static safety coefficient to fully bring out the performance of the unit type. See Pages 30 to 34 of "Engineering data" for each calculation formula.

■ Checking procedure

(1) Checking the maximum moment load (Mmax)



(2) Checking the life

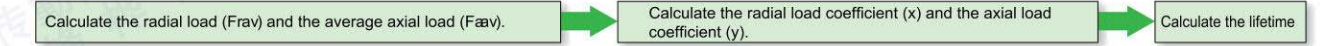

(3) Checking the static safety coefficient

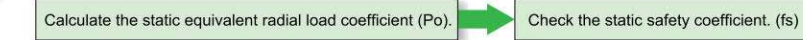

■ Output bearing specifications

The specifications of the cross roller are shown in Table 136-1.

Specifications CSG Series/CSF Series

Table 136-1

Size	Pitch circle dia. of a roller	Offset	Basic rated load				Allowable moment load		Moment stiffness	
			Basic dynamic rated load		Basic static rated load		Mc			
			C	Co	Mc	Mc	$\times 10^{-4}$ Nm/rad	kgfm/arc min		
14	0.035	0.0095	47	480	60.7	620	41	4.2	4.38	1.3
17	0.0425	0.0095	52.9	540	75.5	770	64	6.5	7.75	2.3
20	0.050	0.0095	57.8	590	90.0	920	91	9.3	12.8	3.8
25	0.062	0.0115	96.0	980	151	1540	156	16	24.2	7.2
32	0.080	0.013	150	1530	250	2550	313	32	53.9	16
40	0.096	0.0145	213	2170	365	3720	450	46	91.0	27
45	0.111	0.0155	230	2350	426	4340	686	70	141	42
50	0.119	0.018	348	3550	602	6140	759	77	171	51
58	0.141	0.0205	518	5290	904	9230	1180	120	283	84
65	0.160	0.0225	556	5670	1030	10500	1860	190	404	120

* Basic dynamic rated load is a constant radial load where the basic dynamic rated life of CRB is 1×10^6 rotations.

* Basic static rated load is a static load where the value of moment rigidity is the average value.

* The value of the moment stiffness is the average value.

Recommended Tolerances for Assembly

Recommended tolerances for assembly

Fig. 137-1

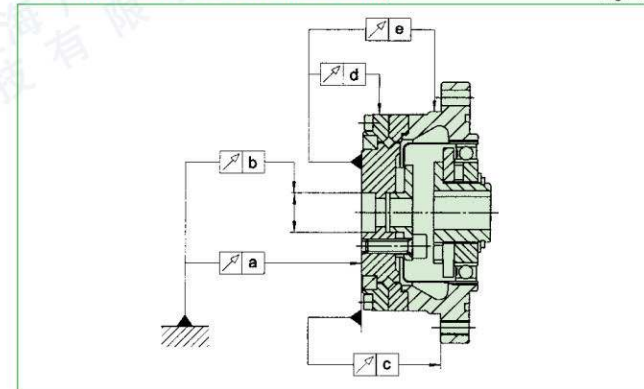

Table 137-1

Unit: mm

Symbol	Size	14	17	20	25	32	40	45	50	58	65
a		0.010	0.010	0.010	0.015	0.015	0.015	0.018	0.018	0.018	0.018
b		0.010	0.012	0.012	0.013	0.013	0.015	0.015	0.015	0.017	0.017
c		0.024	0.026	0.038	0.045	0.056	0.060	0.068	0.069	0.076	0.085
d		0.010	0.010	0.010	0.010	0.010	0.015	0.015	0.015	0.015	0.015
e		0.038	0.038	0.047	0.049	0.054	0.060	0.065	0.067	0.070	0.075

Design Guide

Installation accuracy

For peak performance of your gear, maintain the recommended tolerances shown in Figure 137-1 and Table 137-1.

Recommended tolerances for installation

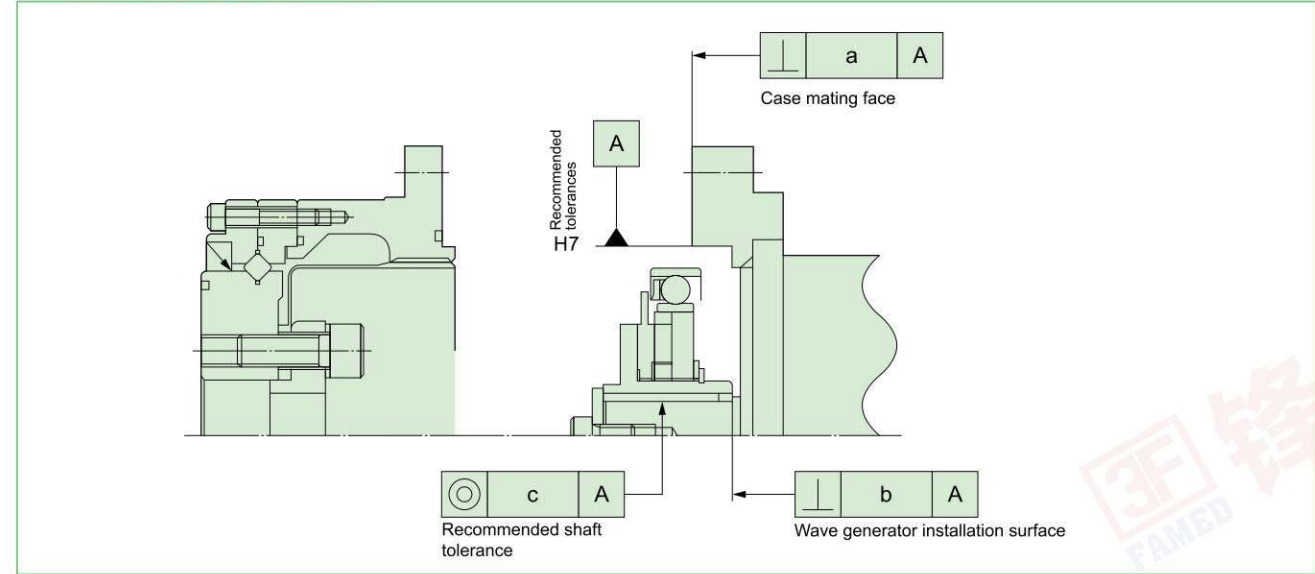

Fig. 137-2

Recommended Tolerances for Assembly

Table 137-2
Unit: mm

Symbol	Size	14	17	20	25	32	40	45	50	58	65
a		0.011	0.015	0.017	0.024	0.026	0.026	0.027	0.028	0.031	0.034
b		0.017	0.020	0.020	0.024	0.024	0.032	0.032	0.032	0.032	0.032
		(0.008)	(0.010)	(0.010)	(0.012)	(0.012)	(0.012)	(0.013)	(0.015)	(0.015)	(0.015)
c		0.030	0.034	0.044	0.047	0.050	0.063	0.065	0.066	0.068	0.070
		(0.016)	(0.018)	(0.019)	(0.022)	(0.022)	(0.024)	(0.027)	(0.030)	(0.033)	(0.035)

* The value in the parentheses indicates that input (wave generator) is a solid wave generator.

Installation and transmission torque

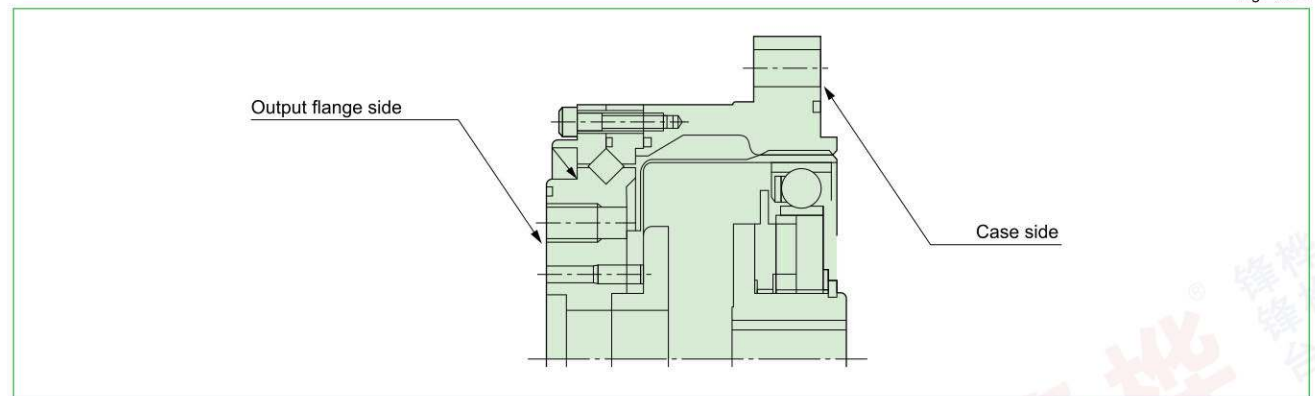

Fig. 138-1

CSG series: Installation of output flange side and transmission torque

Table 138-1

Item	Size	14	17	20	25	32	40	45	50	58	65
Number of bolts		6	6	8	8	8	8	8	8	8	8
Bolt size		M4	M5	M6	M8	M10	M10	M12	M14	M16	M16
Pitch circle	mm	23	27	32	42	55	68	82	84	100	110
Clamp torque	Nm	5.4	10.8	18.4	45	89	89	154	246	383	383
Torque transmission capacity (bolt only)	Nm	58	109	245	580	1220	1510	2624	3690	5981	6579

CSG series: Installation of case side and transmission torque

Table 138-2

Item	Size	14	17	20	25	32	40	45	50	58	65
Number of bolts		8	8	8	10	12	10	12	14	12	8
Bolt size		M4	M4	M5	M5	M6	M8	M8	M8	M10	M12
Pitch circle	mm	65	71	82	96	125	144	164	174	206	236
Clamp torque	Nm	4.5	4.5	9.0	9.0	15.3	37	37	37	74	128
Torque transmission capacity (bolt only)	Nm	182	196	365	538	1200	2100	2844	3251	5717	6293

(Table 138-1, 138-2/Notes)

1. The material of the thread must withstand the clamp torque.
2. Recommended bolt: JIS B 1176 socket head cap screw / Strength range: JIS B 1051 over 12.9.
3. Torque coefficient: K=0.2
4. Clamp coefficient: A=1.4
5. Tightening friction coefficient $\mu=0.15$

CSF series: Bolt connection to output flange and resulting transmission torque

Table 139-1

Item	Size	14	17	20	25	32	40	45	50	58	65
Number of bolts		6	6	8	8	8	8	8	8	8	8
Bolt size		M4	M5	M6	M8	M10	M10	M12	M14	M16	M16
Pitch circle	mm	23	27	32	42	55	68	82	84	100	110
Clamp torque	Nm	4.5	9	15.3	37	74	74	128	205	319	319
Torque transmission capacity (bolt only)	Nm	49	91	204	486	1108	1258	2200	3070	4980	5480

CSF series: Bolt connection to output flange and resulting transmission torque

Table 139-2

Item	Size	14	17	20	25	32	40	45	50	58	65
Number of bolts		6	6	6	8	12	8	12	12	12	8
Bolt size		M4	M4	M5	M5	M6	M8	M8	M8	M10	M12
Pitch circle	mm	65	71	82	96	125	144	164	174	206	236
Clamp torque	Nm	4.5	4.5	9.0	9.0	15.3	37	37	37	74	128
Torque transmission capacity (bolt only)	Nm	137	147	274	431	1200	1680	2860	3040	5670	6310

(Table 139-1, 139-2/Notes)

1. The material of the thread must withstand the clamp torque.
2. Recommended bolt: JIS B 1176 socket head cap screw / Strength range: JIS B 1051 over 12.9.
3. Torque coefficient: K=0.2
4. Clamp coefficient: A=1.4
5. Tightening friction coefficient $\mu=0.15$

Precautions on installing the load to the output flange (Sizes 14 to 25)

As the distance (see the size symbol "L" in Figure 128-1 on Page 128) between the oil seal on the output flange periphery and the edge of the output flange (rotor) is short for the gear units sizes 14, 17, 20 and 25, the load may interfere with the oil seal. Produce a design so that the load cannot be applied to the oil seal.

Installation of a motor

Motor mounting flange

A motor mounting flange is required for installing a motor. The recommended size and precision of the basic part of the motor mounting flange is shown in Table 140-1.

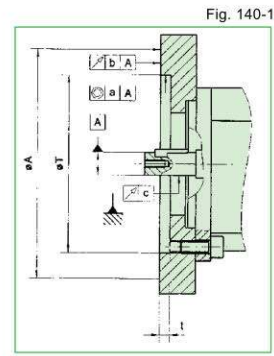

Table 140-1
Unit: mm

Symbol	Size	14	17	20	25	32	40	45	50	58	65
a		0.03	0.04	0.04	0.04	0.04	0.05	0.05	0.05	0.05	0.05
b		0.03	0.04	0.04	0.04	0.04	0.05	0.05	0.05	0.05	0.05
c		0.015	0.015	0.018	0.018	0.018	0.018	0.021	0.021	0.021	0.021
φA		73	79	93	107	138	160	180	190	226	260
t		3	3	4.5	4.5	4.5	6	6	6	7.5	7.5
φT		38H7	48H7	56H7	67H7	90H7	110H7	124H7	135H7	156H7	177H7

Installation procedure

As shown in Figures 141-1 and 141-2, there are two basic procedures to install a motor. Select the installation procedure by the diameter of the pilot hole on the motor mounting surface. Table 141-1 shows the selection standard by the diameter of the pilot hole on the motor mounting surface.

Table 141-1
Unit: mm

Size	14	17	20	25	32	40	45	50	58	65	Reference drawing for installation
The dia. of the pilot hole on the motor mounting surface	< 35.5 ≧ 35.5	< 43.5 ≧ 43.5	< 50.0 ≧ 50.0	< 62.5 ≧ 62.5	< 81.5 ≧ 81.5	< 100.0 ≧ 100.0	< 113.5 ≧ 113.5	< 124.5 ≧ 124.5	< 147 ≧ 147	< 167 ≧ 167	Installation procedure-1 (Fig. 141-1) Installation procedure-2 (Fig. 141-2)

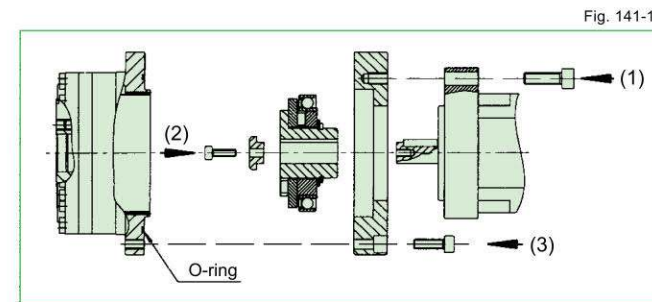

Installation procedure-1

- Install the mounting flange on the motor mounting surface.
- Install a wave generator on the motor output shaft.
- Install the main unit.

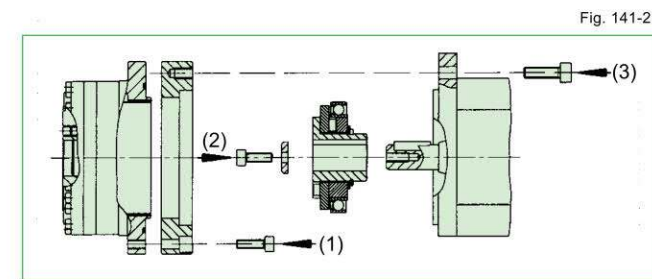

Installation procedure-2

- Install the mounting flange on the main unit.
- Install a wave generator on the motor output shaft.
- Install the mounting flange (main unit) on the motor mounting surface.

Precautions on assembly

It is extremely important to assemble the gear accurately, in proper sequence. Perform assembly based on the following precautions.

Precautions regarding the wave generator

- Avoid applying undue axial force to the wave generator during installation. Rotating the wave generator bearing while inserting it is recommended and will ease the process.
- If the wave generator does not have an Oldham coupling, extra care must be given to ensure that concentricity and inclination are within the specified limits (see "Installation accuracy" of each series on Page 137).

Other precautions

- Is the flatness of the mounting surface poor or distorted?
- Is any embossment of the screw hole area, burr or trapped foreign matter found?
- Have chamfering and relief working of the corner been performed to prevent interference with the area of installation of the unit?

Rust-prevention

Although Harmonic Drive® gears come with some corrosion protection, the gear can rust if exposed to the environment. The gear external surfaces typically have only a temporary corrosion inhibitor and some oil applied. If an anti-rust product is needed, please contact us to review the options.

Lubrication

Grease lubrication is standard for the CSF/CSG gear units. Harmonic Grease SK-2 is for sizes 14 and 17, and Harmonic Grease SK-1A is for sizes 20 to 65 (Harmonic Grease 4B No.2 for the cross roller bearing). Harmonic Grease 4B No.2 is also available for long-life and for use in a wide temperature range. (see "Engineering data" for the specifications of the grease).

See table below for recommended housing dimensions. These dimensions must be maintained to prevent damage to the gear and to maintain a proper grease cavity.

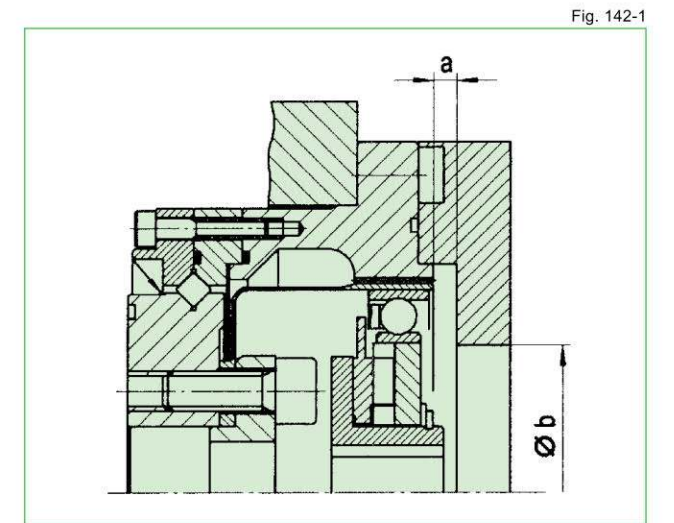

Fig. 142-1

Recommended housing dimensions

Table 142-1
Unit: mm

Symbol	Size	14	17	20	25	32	40	45	50	58	65
a*		1	1	1.5	1.5	1.5	2	2	2	2.5	2.5
a**		3	3	4.5	4.5	4.5	6	6	6	7.5	7.5
φb		16	26	30	37	37	45	45	45	56	62

* Horizontal and vertical: when the wave generator is below
** Vertical: when the wave generator is above

Other precautions

Fill the gap between the wave generator and the input cover (motor flange) with grease to use the wave generator facing upward or downward (see Figure 048-3 on Page 48).

Sealing

Sealing is needed to maintain the high durability of the gear and prevent grease leakage

- Rotating Parts** Oil seal (with a spring). Surface should be smooth (no scratches)
- Mating flange** O-ring and seal adhesive. Take care regarding distortion on the plane and how the O-ring is engaged.
- Screw hole area** Screws should have a thread lock (LOCTITE 242 is recommended) or seal adhesive.

(Note) If you use Harmonic Grease 4B No.2, strict sealing is required.

Sealing area and the recommended sealing method for the unit type

Table 142-2

Area requiring sealing		Recommended sealing method
Output side	Pass-through hole in the center of the output flange and the output flange mating face	Use O-ring (supplied with product)
	Spanner screw area	Screw lock agent with sealing effect (LOCTITE® 242 is recommended)
Input side	Flange mating face	Use O-ring (supplied with product)
	Motor output shaft	Please select a motor which has an oil seal on the output shaft.

Rust prevention

Although Harmonic Drive® gears come with some corrosion protection, the gear can rust if exposed to the environment. The gear external surfaces typically have only a temporary corrosion inhibitor and some oil applied. If an anti-rust product is needed, please contact us to review the options.

Application

Multi-joint Robot

Fig. 143-1

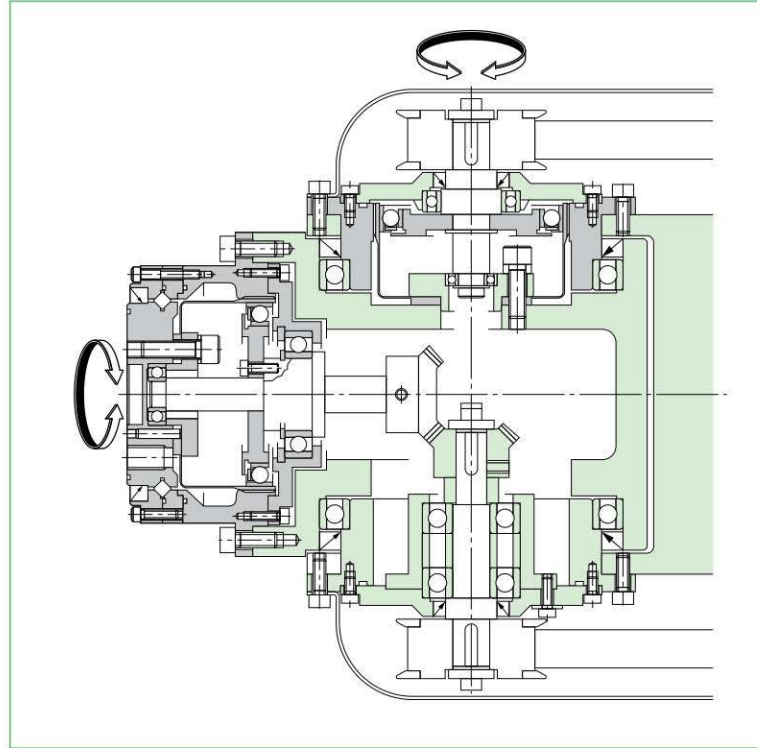

Horizontal Multi Arm Robot

Fig. 144-1

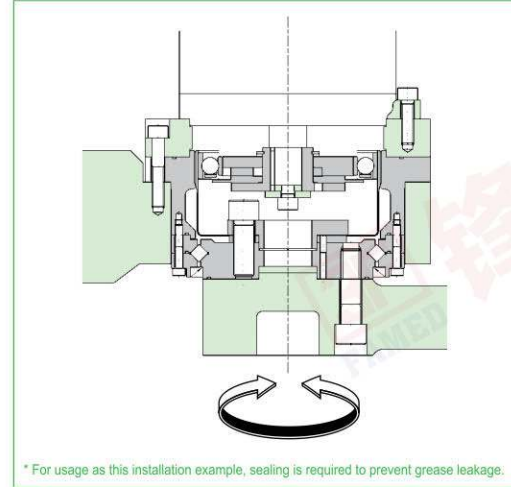

Direct Connection to a Servomotor

Fig. 144-2

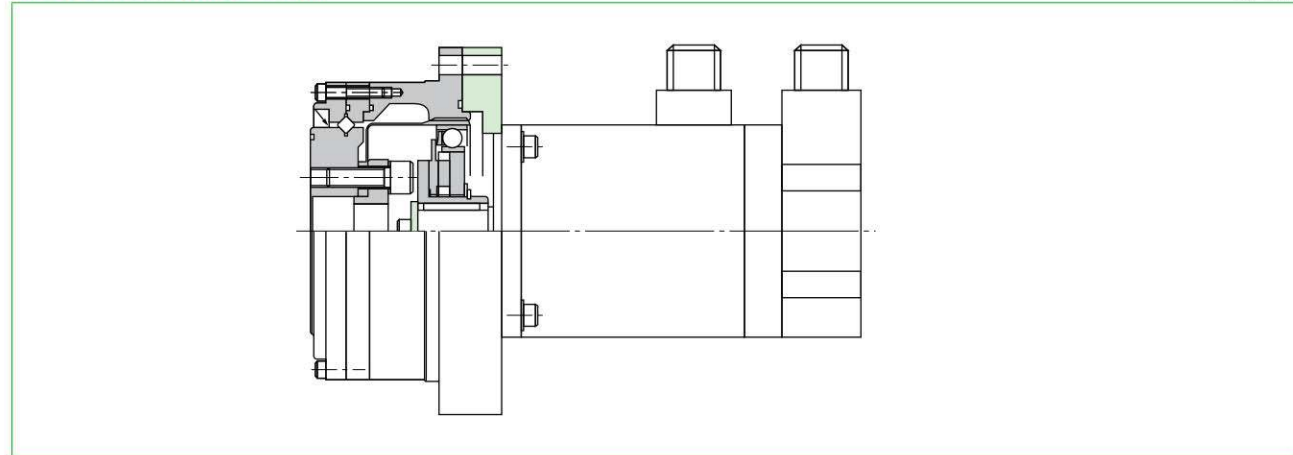

Optional Input Shaft

CSF/CSG-2UJ with optional input shaft

Fig. 144-3

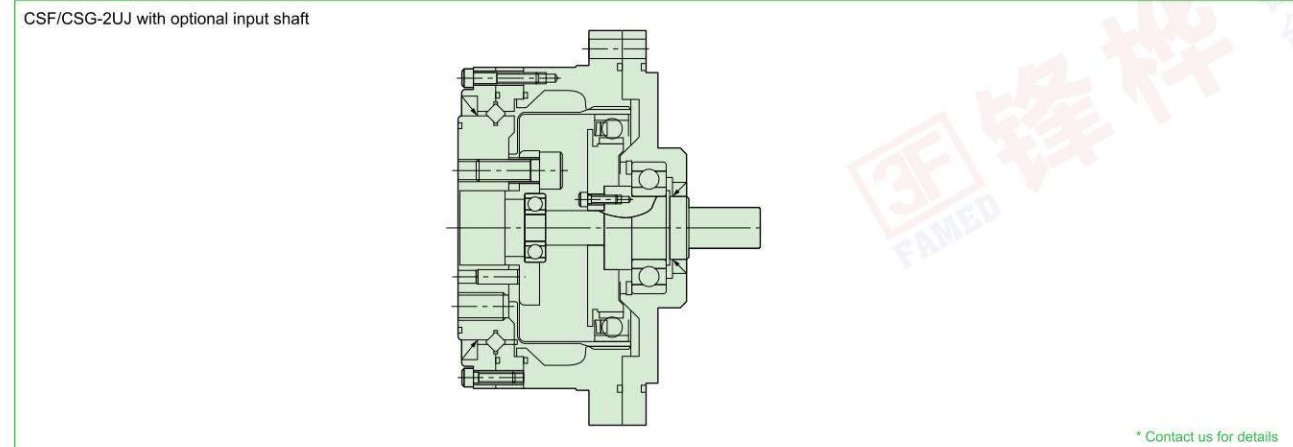

Features



SHG/SHF series gear units

The SHG/SHF series gear unit is an easy-to-use gearhead solution. An accurate, highly rigid cross roller bearing is built in to directly support the external load.

Features

- Zero backlash
- Large bore with hollow through hole
- Input shaft option available
- Flat shape, compact and simple design
- High-torque capacity
- High stiffness
- High-positional and rotational accuracies
- Coaxial input and output

Configurations

The SHG/SHF gearheads are available in 4 variations allowing the customer to choose the best configuration for their application.

- Large-diameter hollow shaft: (2UH)
- Input shaft (2UJ)
- Easier to use: Simplicity unit (2SO)
Hollow shaft simplicity unit (2SH)

Series

SHG: high torque

- Torque capacity has been improved by 30% compared to the SHF series.
- The life has been improved by 43% (10,000 hours) compared to the SHF series.

SHF: standard torque

- Reduction ratio of 30:1 added for high speed.

Structure of the SHG/SHF series gear unit

Fig. 228-1

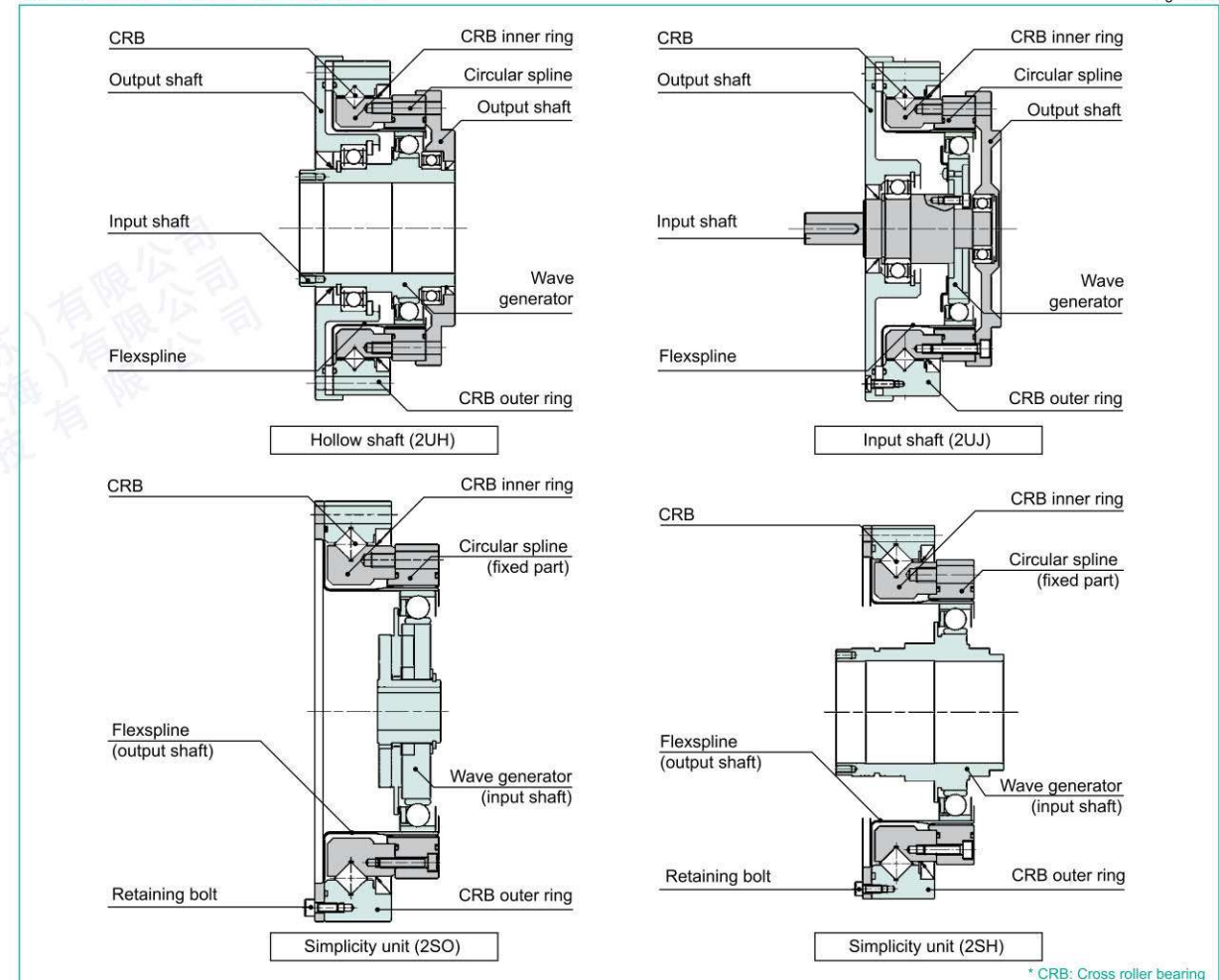

Ordering Code

SHG - 25 - 100 - 2UH - SP

Series	Size	Ratio *1						Model	Special specification
SHG	14	50	80	100	—	—	2A-GR = Component set (2A-R for sizes 14, 17) 2UH = Hollow shaft 2UJ = Input shaft 2SO = Simplicity unit (Std. structure) 2SH = Simplicity unit (Hollow shaft)	LW = Lightweight SP = Special specification code Blank = Standard product	
	17	50	80	100	120	—			
	20	50	80	100	120	160			
	25	50	80	100	120	160			
	32	50	80	100	120	160			
	40	50	80	100	120	160			
	45	50	80	100	120	160			
	50	—	80	100	120	160			
	58	—	80	100	120	160			
65	—	80	100	120	160				

*1: The reduction ratio value is based on the following configuration: Input: wave generator, fixed: circular spline, output: flexspline

Technical Data

Rating table

SHG series

Size	Ratio	Rated torque at 2000rpm		Limit for repeated peak torque		Limit for average torque		Limit for momentary peak torque		Maximum input speed (rpm)		Limit for average input speed (rpm)	
		Nm	kgfm	Nm	kgfm	Nm	kgfm	Nm	kgfm	Oil lubricant	Grease lubricant	Oil lubricant	Grease lubricant
		14	50	7.0	0.7	23	2.3	9	0.9	46	4.7	14000	8500
17	80	10	1.0	30	3.1	14	1.4	61	6.2	10000	7300	6500	3500
	100	10	1.0	36	3.7	14	1.4	70	7.2				
	120	31	3.2	70	7.2	51	5.2	143	15				
20	50	21	2.1	44	4.5	34	3.4	91	9	10000	6500	6500	3500
	80	29	2.9	56	5.7	35	3.6	113	12				
	100	31	3.2	70	7.2	51	5.2	143	15				
	120	31	3.2	70	7.2	51	5.2	112	11				
25	50	33	3.3	73	7.4	44	4.5	127	13	7500	5600	5600	3500
	80	44	4.5	96	9.8	61	6.2	165	17				
	100	52	5.3	107	10.9	64	6.5	191	20				
	120	52	5.3	113	11.5	64	6.5	191	20				
32	50	51	5.2	127	13	72	7.3	242	25	7000	4800	4600	3500
	80	82	8.4	178	18	113	12	332	34				
	100	87	8.9	204	21	140	14	369	38				
	120	87	8.9	217	22	140	14	395	40				
40	50	99	10	281	29	140	14	497	51	5600	4000	3600	3000
	80	153	16	395	40	217	22	738	75				
	100	178	18	433	44	281	29	841	86				
	120	178	18	459	47	281	29	892	91				
45	50	178	18	523	53	255	26	892	91	5000	3800	3300	3000
	80	268	27	675	69	369	38	1270	130				
	100	345	35	738	75	484	49	1400	143				
	120	382	39	802	82	586	60	1530	156				
50	50	229	23	650	66	345	35	1235	126	4500	3500	3000	2500
	80	407	41	918	94	507	52	1651	168				
	100	459	47	982	100	650	66	2041	208				
	120	523	53	1070	109	806	82	2288	233				
58	50	523	53	1147	117	819	84	2483	253	4000	3000	2700	2200
	80	484	49	1223	125	675	69	2418	247				
	100	611	62	1274	130	866	88	2678	273				
	120	688	70	1404	143	1057	108	2678	273				
65	50	688	70	1534	156	1096	112	3185	325	3500	2800	2400	1900
	80	714	73	1924	196	1001	102	3185	325				
	100	905	92	2067	211	1378	141	4134	422				
	120	969	99	2236	228	1547	158	4329	441				

(Note) 1. Moment of inertia : $I = \frac{1}{4}GD^2$
2. See Rating Table Definitions on Page 12 for details of the terms.

Ordering Code

SHF - 25 - 100 - 2UH - SP

Series	Size	Ratio *1						Model	Special specification	
SHF	11*2	—	50	—	100	—	—	2A-GR = Component set (2A-R for sizes 14, 17) 2UH = Hollow shaft 2UJ = Input shaft 2SO = Simplicity unit (Std. structure) 2SH = Simplicity unit (Hollow shaft)	LW = Lightweight SP = Special specification code Blank = Standard product	
	14	30	50	80	100	—	—			
	17	30	50	80	100	120	—			—
	20	30	50	80	100	120	160			—
	25	30	50	80	100	120	160			—
	32	30	50	80	100	120	160			—
	40	—	50	80	100	120	160			—
	45	—	50	80	100	120	160			—
	50	—	50	80	100	120	160			—
	58	—	50	80	100	120	160			—

*1: The reduction ratio value is based on the following configuration: Input: wave generator, fixed: circular spline, output: flexspline
*2: Size 11 is only available in SHF-2UH

Rating table

SHF series

Size	Ratio	Rated torque at 2000rpm		Limit for repeated peak torque		Limit for average torque		Limit for momentary peak torque		Maximum input speed (rpm)		Limit for average input speed (rpm)	
		Nm	kgfm	Nm	kgfm	Nm	kgfm	Nm	kgfm	Oil lubricant	Grease lubricant	Oil lubricant	Grease lubricant
		11	50	3.5	0.36	8.3	0.85	5.5	0.56	17	1.73	14000	8500
14	100	5	0.51	11	1.12	8.9	0.91	25	2.55	14000	8500	6500	3500
	30	4.0	0.41	9.0	0.92	6.8	0.69	17	1.7				
	50	5.4	0.55	18	1.8	6.9	0.70	35	3.6				
17	80	7.8	0.80	23	2.4	11	1.1	47	4.8	10000	7300	6500	3500
	100	7.8	0.80	28	2.9	11	1.1	54	5.5				
	30	8.8	0.90	16	1.6	12	1.2	30	3.1				
	50	16	1.6	34	3.5	26	2.6	70	7.1				
20	80	22	2.2	43	4.4	27	2.7	87	8.9	10000	6500	6500	3500
	100	24	2.4	54	5.5	39	4.0	110	11				
	120	24	2.4	54	5.5	39	4.0	86	8.8				
	30	15	1.5	27	2.8	20	2.0	50	5.1				
25	50	25	2.5	56	5.7	34	3.5	98	10	7500	5600	5600	3500
	80	34	3.5	74	7.5	47	4.8	127	13				
	100	40	4.1	82	8.4	49	5.0	147	15				
	120	40	4.1	87	8.9	49	5.0	147	15				
32	50	27	2.8	50	5.1	38	3.9	95	9.7	7000	4800	4600	3500
	80	39	4.0	98	10	55	5.6	186	19				
	100	63	6.4	137	14	87	8.9	255	26				
	120	67	6.8	157	16	108	11	284	29				
40	50	67	6.8	167	17	108	11	304	31	5600	4000	3600	3000
	80	67	6.8	176	18	108	11	314	32				
	100	54	5.5	100	10	75	7.7	200	20				
	120	54	5.5	100	10	75	7.7	200	20				
45	50	76	7.8	216	22	108	11	382	39	5000	3800	3300	3000
	80	118	12	304	31	167	17	568	58				
	100	137	14	333	34	216	22	647	66				
	120	137	14	353	36	216	22	686	70				
50	50	137	14	402	41	196	20	686	70	4500	3500	3000	2500
	80	206	21	519	53	284	29	980	100				
	100	265	27	568	58	372	38	1080	110				
	120	294	30	617	63	451	46	1180	120				
58	50	294	30	647	66	451	46	1180	120	4000	3000	2700	2200
	80	176	18	500	51	265	27	950	97				
	100	313	32	706	72	390	40	1270	130				
	120	353	36	755	77	500	51	1570	160				
65	50	402	41	823	84	620	63	1760	180	3500	2800	2400	1900
	80	402	41	882	90	630	64	1910	195				
	100	122	12	715	73	175	18	1430	146				
	120	372	38	941	96	519	53	1860	190				

(Note) 1. Oil lubrication is standard for gear units size 50 or larger with a reduction ratio of 50. Use grease lubrication within half the rated torque.
2. Moment of inertia : $I = \frac{1}{4}GD^2$
3. See Rating Table Definitions on Page 12 for details of the terms.
4. Size 11 is only available in 2UH.

Positional accuracy

See "Engineering data" for a description of terms.

Table 232-1

Ratio	Specification	Size	11	14	17	20	25	32	40 or more
30	Standard product	× 10°rad	—	5.8	4.4	4.4	4.4	4.4	—
		arc min	—	2	1.5	1.5	1.5	1.5	—
	Special product	× 10°rad	—	—	—	2.9	2.9	2.9	—
		arc min	—	—	—	1	1	1	—
50 or more	Standard product	× 10°rad	5.8(4.4)	4.4	4.4	2.9	2.9	2.9	2.9
		arc min	2(1.5)	1.5	1.5	1	1	1	1
	Special product	× 10°rad	—	2.9	2.9	1.5	1.5	1.5	1.5
		arc min	—	1	1	0.5	0.5	0.5	0.5

Note 1: * The parenthesized value of size 11 indicates the value for reduction ratio 100.

Hysteresis loss

See "Engineering data" for a description of terms.

Table 232-2

Ratio	Unit	Size	11	14	17	20	25	32	40 or more
30	× 10°rad	arc min	—	8.7	8.7	8.7	8.7	8.7	—
		arc min	—	3.0	3.0	3.0	3.0	3.0	—
50	× 10°rad	arc min	5.8	5.8	5.8	5.8	5.8	5.8	5.8
		arc min	2.0	2.0	2.0	2.0	2.0	2.0	2.0
80 or more	× 10°rad	arc min	5.8	2.9	2.9	2.9	2.9	2.9	2.9
		arc min	2.0	1.0	1.0	1.0	1.0	1.0	1.0

Backlash

See "Engineering data" for a description of terms.

Table 232-3

Ratio	Size	11	14	17	20	25	32	40	45	50	58	65
30	× 10°rad	—	29.1	16.0	13.6	13.6	11.2	—	—	—	—	—
	arc sec	—	60	33	28	28	23	—	—	—	—	—
50	× 10°rad	Note 1	17.5	9.7	8.2	8.2	6.8	6.8	5.8	5.8	4.8	—
	arc sec	Note 1	36	20	17	17	14	14	12	12	10	—
80	× 10°rad	—	11.2	6.3	5.3	5.3	4.4	4.4	3.9	3.9	2.9	2.9
	arc sec	—	23	13	11	11	9	9	8	8	6	6
100	× 10°rad	Note 1	8.7	4.8	4.4	4.4	3.4	3.4	2.9	2.9	2.4	2.4
	arc sec	Note 1	18	10	9	9	7	7	6	6	5	5
120	× 10°rad	—	—	3.9	3.9	3.9	2.9	2.9	2.4	2.4	1.9	1.9
	arc sec	—	—	8	8	8	6	6	5	5	4	4
160	× 10°rad	—	—	—	2.9	2.9	2.4	2.4	1.9	1.9	1.5	1.5
	arc sec	—	—	—	6	6	5	5	4	4	3	3

Note 1: For size 11, the wave generator is a solid wave generator. See "Engineering data" for details.

Torsional stiffness

See "Engineering data" for a description of terms.

Table 232-4

Symbol	Size	11	14	17	20	25	32	40	45	50	58	65
T ₁	Nm	0.8	2.0	3.9	7.0	14	29	54	76	108	168	235
	kgfm	0.082	0.2	0.4	0.7	1.4	3.0	5.5	7.8	11	17	24
T ₂	Nm	2.0	6.9	12	25	48	108	196	275	382	598	843
	kgfm	0.2	0.7	1.2	2.5	4.9	11	20	28	39	61	86
Reduction ratio 30	K ₁	× 10°Nm/rad	—	0.19	0.34	0.57	1.0	2.4	—	—	—	—
		kgfm/arc min	—	0.056	0.10	0.17	0.30	0.70	—	—	—	—
	K ₂	× 10°Nm/rad	—	0.24	0.44	0.71	1.3	3.0	—	—	—	—
		kgfm/arc min	—	0.07	0.13	0.21	0.40	0.89	—	—	—	—
	K ₃	× 10°Nm/rad	—	0.34	0.67	1.1	2.1	4.9	—	—	—	—
		kgfm/arc min	—	0.10	0.20	0.32	0.62	1.5	—	—	—	—
	θ ₁	× 10°rad	—	10.5	11.5	12.3	14	12.1	—	—	—	—
		arc min	—	3.6	4.0	4.1	4.7	4.3	—	—	—	—
	θ ₂	× 10°rad	—	31	30	38	40	38	—	—	—	—
		arc min	—	10.7	10.2	12.7	13.4	13.3	—	—	—	—
Reduction ratio 50	K ₁	× 10°Nm/rad	0.22	0.34	0.81	1.3	2.5	5.4	10	15	20	31
		kgfm/arc min	0.066	0.1	0.24	0.38	0.74	1.6	3.0	4.3	5.9	9.3
	K ₂	× 10°Nm/rad	0.3	0.47	1.1	1.8	3.4	7.8	14	20	28	44
		kgfm/arc min	0.09	0.14	0.32	0.52	1.0	2.3	4.2	6.0	8.2	13
	K ₃	× 10°Nm/rad	0.32	0.57	1.3	2.3	4.4	9.8	18	26	34	54
		kgfm/arc min	0.096	0.17	0.4	0.67	1.3	2.9	5.3	7.6	10	16
	θ ₁	× 10°rad	3.6	5.8	4.9	5.2	5.5	5.5	5.2	5.5	5.2	—
		arc min	1.2	2.0	1.7	1.8	1.9	1.9	1.8	1.8	1.9	—
	θ ₂	× 10°rad	8.0	16	12	15.4	15.7	15.4	15.4	15.1	15.4	15.1
		arc min	2.6	5.6	4.2	5.3	5.4	5.4	5.3	5.2	5.3	—

* The values in this table are reference values. The minimum value is approximately 80% of the displayed value.

Table 233-1

Symbol	Size	11	14	17	20	25	32	40	45	50	58	65	
T ₁	Nm	0.8	2.0	3.9	7.0	14	29	54	76	108	168	235	
	kgfm	0.82	0.2	0.4	0.7	1.4	3.0	5.5	7.8	11	17	24	
T ₂	Nm	2	6.9	12	25	48	108	196	275	382	598	843	
	kgfm	0.2	0.7	1.2	2.5	4.9	11	20	28	39	61	86	
Reduction ratio 80 or more	K ₁	× 10°Nm/rad	0.27	0.47	1	1.6	3.1	6.7	13	18	25	40	54
		kgfm/arc min	0.08	0.14	0.3	0.47	0.92	2.0	3.8	5.4	7.4	12	16
	K ₂	× 10°Nm/rad	0.34	0.61	1.4	2.5	5.0	11	20	29	40	61	88
		kgfm/arc min	0.1	0.18	0.4	0.75	1.5	3.2	6.0	8.5	12	18	26
	K ₃	× 10°Nm/rad	0.44	0.71	1.6	2.9	5.7	12	23	33	44	71	98
		kgfm/arc min	0.13	0.21	0.46	0.85	1.7	3.7	6.8	9.7	13	21	29
	θ ₁	× 10°rad	3	4.1	3.9	4.4	4.4	4.4	4.1	4.1	4.4	4.1	4.4
		arc min	1	1.4	1.3	1.5	1.5	1.5	1.4	1.4	1.5	1.4	1.5
	θ ₂	× 10°rad	6	12	9.7	11.3	11.1	11.6	11.1	11.1	11.1	11.1	11.3
		arc min	2.2	4.2	3.3	3.9	3.8	4.0	3.8	3.8	3.8	3.8	3.9

* The values in this table are reference values. The minimum value is approximately 80% of the displayed value.

Ratcheting torque

See "Engineering data" for a description of terms.

Table 233-2

■ SHG series Unit:Nm

Ratio	Size	14	17	20	25	32	40	45	50	58	65
50		110	190	280	580	1200	2300	3500	—	—	—
80		140	260	450	880	1800	3600	5000	7000	10000	14000
100		100	200	330	650	1300	2700	4000	5300	8300	12000
120		—	150	310	610	1200	2400	3600	4900	7500	10000
160		—	—	280	580	1200	2300	3300	4600	7200	10000

Table 233-3

■ SHF series Unit:Nm

Ratio	Size	11	14	17	20	25	32	40	45	50	58
30		—	59	100	170	340	720	—	—	—	—
50		34	88	150	220	450	980	1800	2700	3700	5800
80		—	110	200	350	680	1400	2800	3900	5400	8200
100		43	84	160	260	500	1000	2100	3100	4100	6400
120		—	—	120	240	470	980	1900	2800	3800	5800
160		—	—	—	220	450	980	1800	2600	3600	5600

Buckling torque

See "Engineering data" for a description of terms.

Table 233-4

■ SHG series Unit:Nm

Size	14	17	20	25	32	40	45	50	58	65
Total reduction ratio	210	420	700	1300	2800	5200	7600	10400	16200	22800

Table 233-5

■ SHF series Unit:Nm

Size	11	14	17	20	25	32	40	45	50	58
Total reduction ratio	90	140	270	440	890	1750	3750	5400	7500	11800

Checking output bearing

A precision cross roller bearing is built in the unit type to directly support the external load (output flange).

Please calculate maximum moment load, life of cross roller bearing, and static safety factor to fully maximize the performance of housed unit (gearhead).

See Pages 030 to 034 of "Engineering data" for each calculation formula.

Checking procedure

(1) Checking the maximum moment load (Mmax)



(2) Checking the life

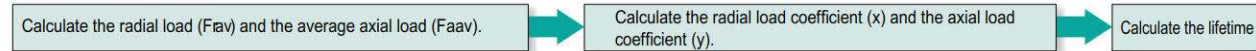

(3) Checking the static safety coefficient



Output bearing specifications

The specifications of the cross roller are shown in Table 234-1.

Specifications

Table 234-1

Size	Pitch circle dp m	Offset R m	Basic rated load				Allowable moment load Mc		Moment stiffness Km	
			Basic dynamic rated load C		Basic static rated load Co		Nm	kgfm	×10 ³ Nm/rad	kgfm/arc min
			×10 ³ N	kgf	×10 ³ N	kgf				
11	0.043	0.018	52.9	540	75.5	770	74	7.6	6.5	1.8
14	0.050	0.0217	58	590	86	880	※ 74	7.6	8.5	2.5
17	0.060	0.0239	104	1060	163	1670	※ 124	12.6	15.4	4.6
20	0.070	0.0255	146	1490	220	2250	※ 187	19.1	25.2	7.5
25	0.085	0.0296	218	2230	358	3660	258	26.3	39.2	11.6
32	0.111	0.0364	382	3900	654	6680	580	59.1	100	29.6
40	0.133	0.044	433	4410	816	8330	849	86.6	179	53.2
45	0.154	0.0475	776	7920	1350	13800	1127	115	257	76.3
50	0.170	0.0525	816	8330	1490	15300	1487	152	351	104
58	0.195	0.0622	874	8920	1710	17500	2180	222	531	158
65	0.218	0.072	1300	13300	2230	22700	2740	280	741	220

* The basic dynamic rated load means a certain static radial load so that the basic dynamic rated life of the roller bearing is a million rotations. The basic static rated load means a static load that gives a certain level of contact stress (4 kN/mm²) in the center of the contact area between the rolling element receiving the maximum load and the orbit.

* The value of the moment stiffness is the average value.

Recommended tolerances for assembly

Recommended tolerances for assembly shown below.

Flexspline fixed

Input: Wave generator
Output: Circular spline
Fixed: Flexspline

Hollow Shaft (2UH)

Fig. 235-1

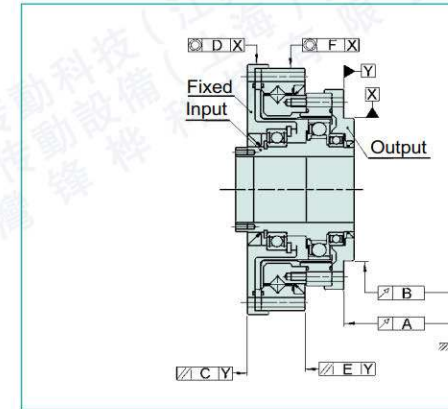

Input shaft (2UJ)

Fig. 235-2

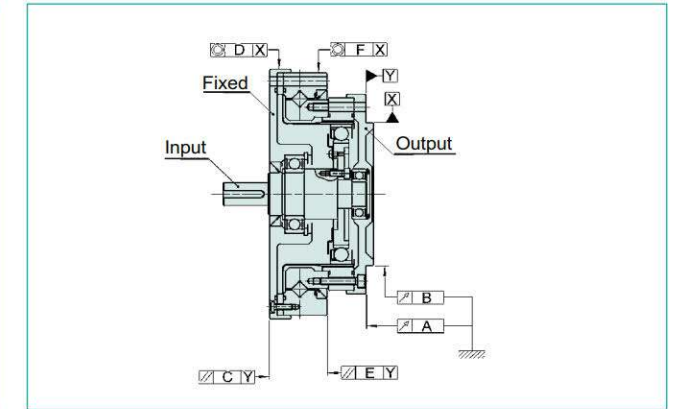

Table 235-1

Unit: mm

Symbol	Size	11	14	17	20	25	32	40	45	50	58	65
A		0.033	0.033	0.038	0.040	0.046	0.054	0.057	0.057	0.063	0.063	0.067
B		0.035	0.035	0.035	0.039	0.041	0.047	0.050	0.053	0.060	0.063	0.063
C		0.053	0.064	0.071	0.079	0.085	0.104	0.111	0.118	0.121	0.121	0.131
D		0.053	0.053	0.050	0.059	0.061	0.072	0.075	0.078	0.085	0.088	0.089
E		0.039	0.040	0.045	0.051	0.057	0.065	0.071	0.072	0.076	0.076	0.082
F		0.038	0.038	0.038	0.047	0.049	0.054	0.060	0.065	0.067	0.070	0.072

Circular spline fixed

Input: Wave generator
Output: Flexspline
Fixed: Circular spline

Hollow shaft (2UH)

Fig. 235-3

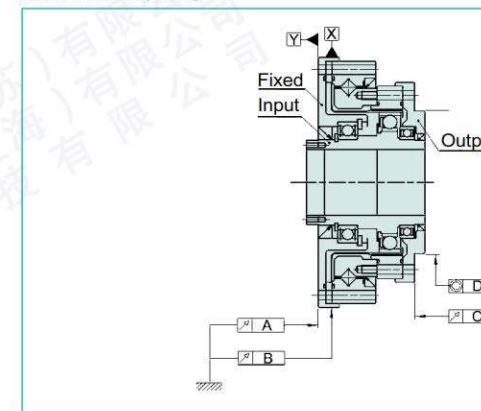

Input shaft (2UJ)

Fig. 235-4

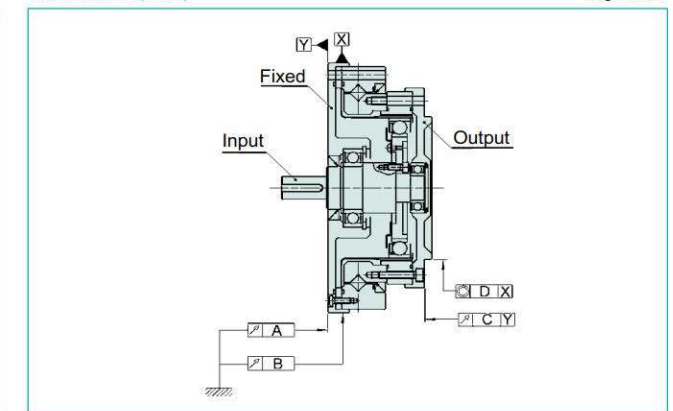

Table 171-2

Unit: mm

Symbol	Size	11	14	17	20	25	32	40	45	50	58	65
A		0.027	0.037	0.039	0.046	0.047	0.059	0.060	0.070	0.070	0.070	0.076
B		0.031	0.031	0.031	0.038	0.038	0.045	0.048	0.050	0.050	0.050	0.054
C		0.053	0.064	0.071	0.079	0.085	0.104	0.111	0.118	0.121	0.121	0.131
D		0.053	0.053	0.053	0.059	0.061	0.072	0.075	0.078	0.085	0.088	0.089

Rotational direction and reduction ratio of a unit type

The rotational direction and the reduction ratio vary depending on the flange to be fixed for the unit type.

■ Flexspline fixed

Input: Wave generator
Output: Circular spline
Fixed: Flexspline

Output rotational direction: Same rotational direction as the input

$$\text{Reduction ratio (i): } i = \frac{1}{R+1}$$

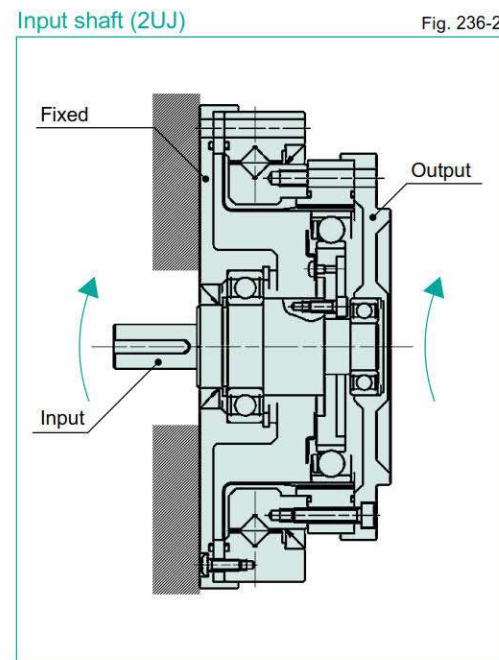
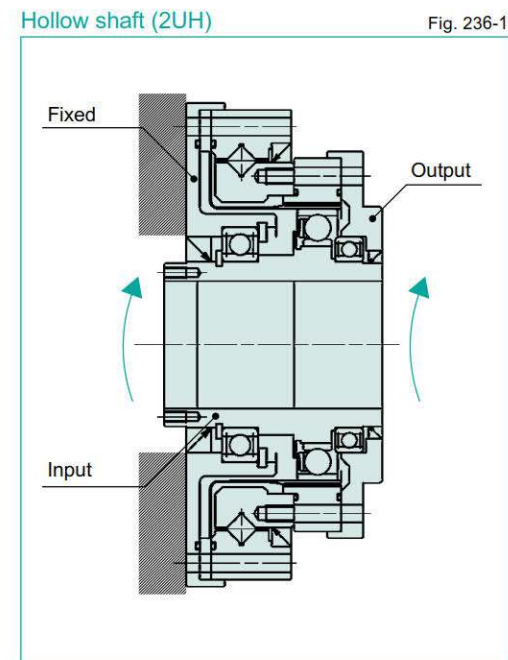

■ Circular spline fixed

Input: Wave generator
Output: Flexspline
Fixed: Circular spline

Output rotational direction: Opposite rotational direction to the input

$$\text{Reduction ratio (i): } i = \frac{-1}{R}$$

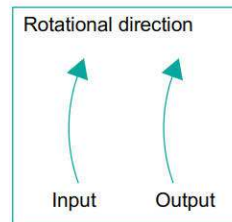
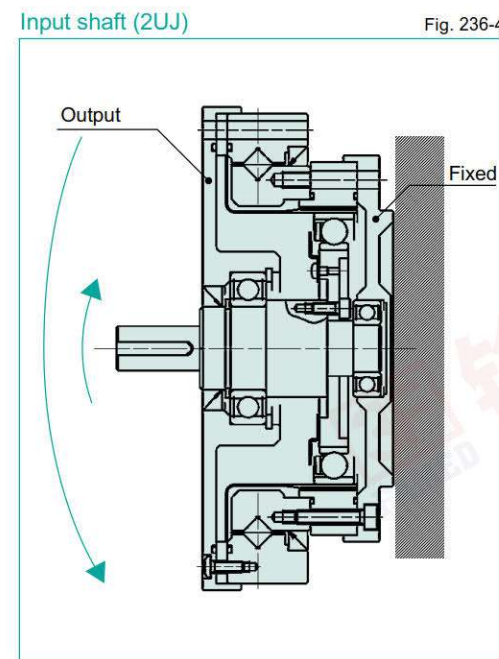
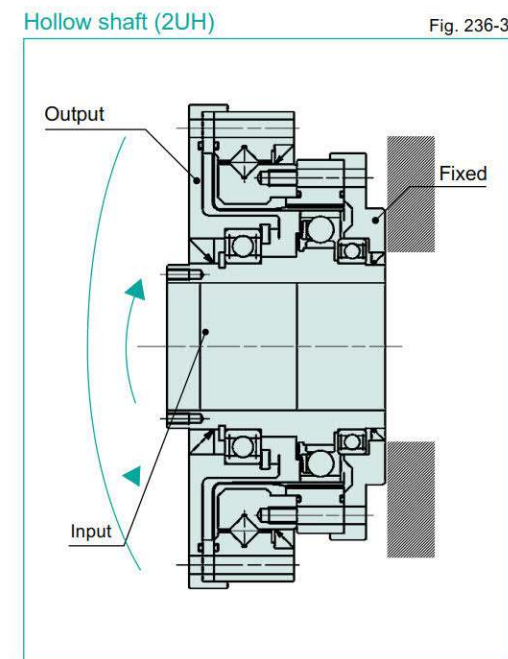

Design Guide

Lubrication

The standard lubricant for Harmonic Drive® gear units is Harmonic Grease SK-1A and SK-2 (Harmonic Grease 4B No.2 for the cross roller bearing). Harmonic Grease 4B No.2 is also available for long-life. The specifications of the grease are described on Page 016.

■ Sealing mechanism

- Rotating and sliding area Oil seal (with a spring). Take care regarding flaws on the shaft.
- Flange mating face and mating O-ring and seal adhesive. distortion on the plane and how the O-ring is engaged.
- Screw hole area Use a screw lock agent (LOCKTITE 242 is recommended) or seal tape.

(Note) If you use Harmonic Grease 4BNo.2, strict sealing is required.

Rust prevention

Although Harmonic Drive® gears come with some corrosion protection, the gear can rust if exposed to the environment. The gear external surfaces typically have only a temporary corrosion inhibitor and some oil applied. If an anti-rust product is needed, please contact us to review the options.

Installation accuracy

For peak performance of the gear, it is essential that the following tolerances be observed when assembly is complete.

Pay careful attention to the following points and maintain the recommended assembly tolerances.

In addition, perform the appropriate installation according to each series, because the torque capacity of SHG series is larger than SHF series.

- Warp and deformation on the mounting surface
- Blocking of foreign matter
- Problems caused by burrs, raised surfaces and location around the tap area of the mounting holes
- Insufficient chamfering on the housing mount
- Insufficient radii on the housing mount

Installation and transmission torque

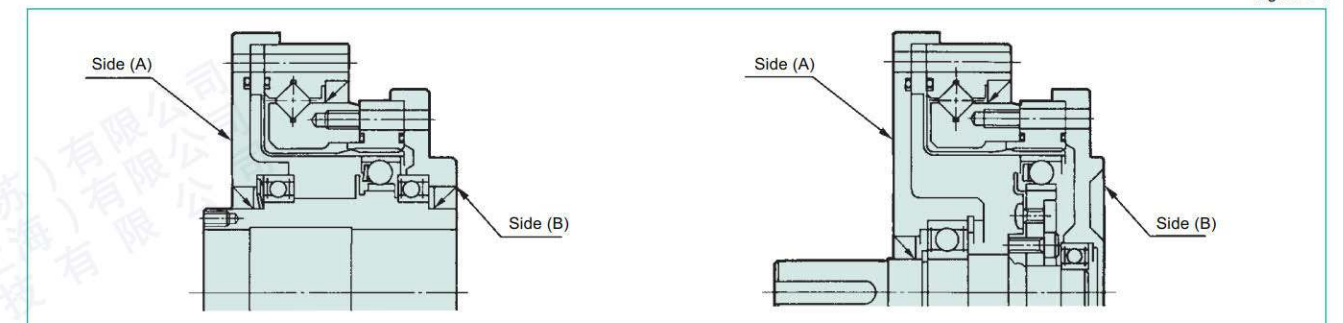

SHG series: (A) Side-installation and Torque Transmission Capacity

Table 238-1

Item	Size	14	17	20	25	32	40	45	50	58	65
Number of bolts		8	12	12	12	12	12	18	12	16	16
Bolt size		M3	M3	M3	M4	M5	M6	M6	M8	M8	M10
Pitch circle	mm	64	74	84	102	132	158	180	200	226	258
Clamp torque	Nm	2.4	2.4	2.4	5.4	10.8	18.4	18.4	44	44	74
Transmission torque	Nm	128	222	252	516	1069	1813	3098	4163	6272	9546

SHF series: (A) Side-installation and Torque Transmission Capacity

Table 238-2

Item	Size	11	14	17	20	25	32	40	45	50	58
Number of bolts		4	8	12	12	12	12	12	18	12	16
Bolt size		M3	M3	M3	M3	M4	M5	M6	M6	M8	M8
Pitch circle	mm	56.4	64	74	84	102	132	158	180	200	226
Clamp torque	Nm	2.0	2.0	2.0	2.0	4.5	9.0	15.3	15.3	37	37
Transmission torque	Nm	47	108	186	206	431	892	1509	2578	3489	5236

(Table 238-1, 238-2/Notes)

1. The material of the thread must withstand the clamp torque.
2. Recommended bolt: JIS B 1176 socket head cap screw / Strength Range: JIS B 1051 12.9 or more
3. Torque coefficient: K=0.2
4. Clamp coefficient: A=1.4
5. Friction coefficient on the surface contacted: $\mu=0.15$
6. Use washers for SHG/SHF-LW.

SHG series: (B) Side-installation and Torque Transmission Capacity

Table 239-1

Item	Size	14	17	20	25	32	40	45	50	58	65
Number of bolts		8	16	16	16	16	16	12	16	12	16
Bolt size		M3	M3	M3	M4	M5	M6	M8	M8	M10	M10
Pitch circle	mm	44	54	62	77	100	122	140	154	178	195
Clamp torque	Nm	2.4	2.4	2.4	5.4	10.8	18.36	44	44	89	89
Transmission torque	Nm	88	216	248	520	1080	1867	2914	4274	5927	8658

SHF series: (B) Side-installation and Torque Transmission Capacity

Table 239-2

Item	Size	11	14	17	20	25	32	40	45	50	58
Number of bolts		6	8	16	16	16	16	16	12	16	12
Bolt size		M3	M3	M3	M3	M4	M5	M6	M8	M8	M10
Pitch circle	mm	37	44	54	62	77	100	122	140	154	178
Clamp torque	Nm	2	2.0	2.0	2.0	4.5	9.0	15.3	37	37	74
Transmission torque	Nm	46	72	176	206	431	902	1558	2440	3587	4910

(Table 239-1, 239-2/Notes)

1. The material of the thread must withstand the clamp torque.
2. Recommended bolt: JIS B 1176 hexagonal bolt / Strength: JIS B 1051 12.9 or more
3. Torque coefficient: K=0.2
4. Clamp coefficient A=1.4
5. Friction coefficient on the surface contacted: $\mu=0.15$

Installation Recommendations

■ Installation on the periphery of the oil seal

Install an oil seal on the mounting face so that they have a space of at least 1 mm between them to avoid interference with each other.

Fig. 240-1

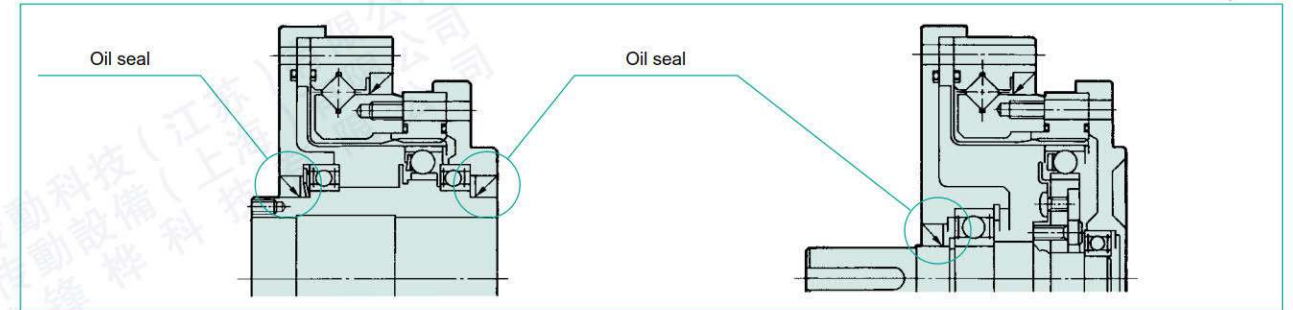

■ Manufacturing for Mating Part and Housing

When the housing interferes with corner "A", an undercut in the housing is recommended as shown below.

Fig. 240-2

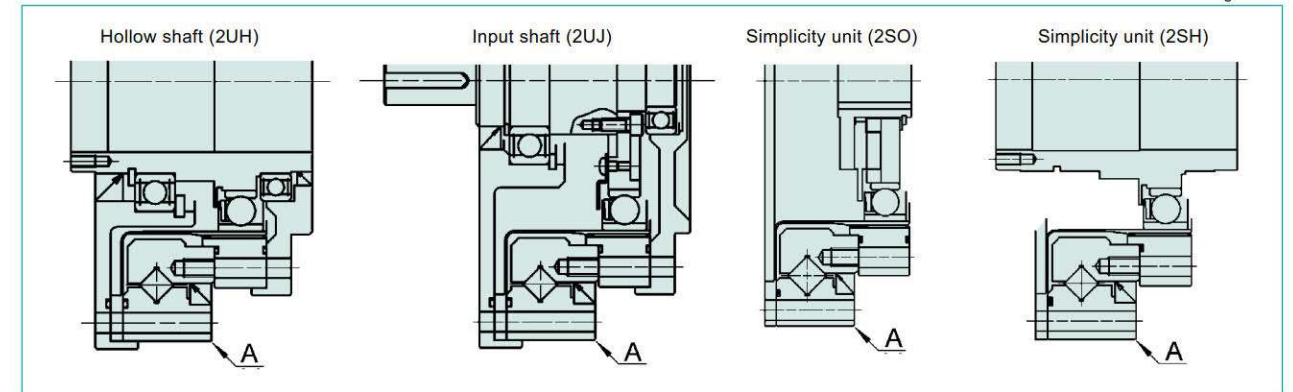

Recommended Housing Undercut

Fig. 240-3
Unit: mm

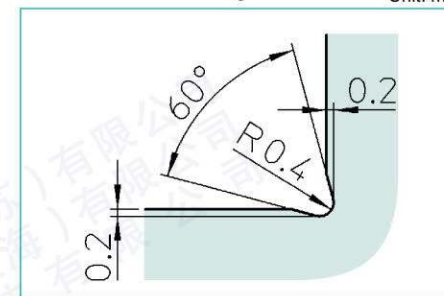

Main markets

Industrial robot

Various mechanical equipment

Vertical multi-joint robot



Multi-joint robot



Wafer adsorption handling device



Outline Dimensions (2UH)

Outline dimensions (2UH)

You can download the CAD files from our website: harmonicdrive.net

Fig. 241-1

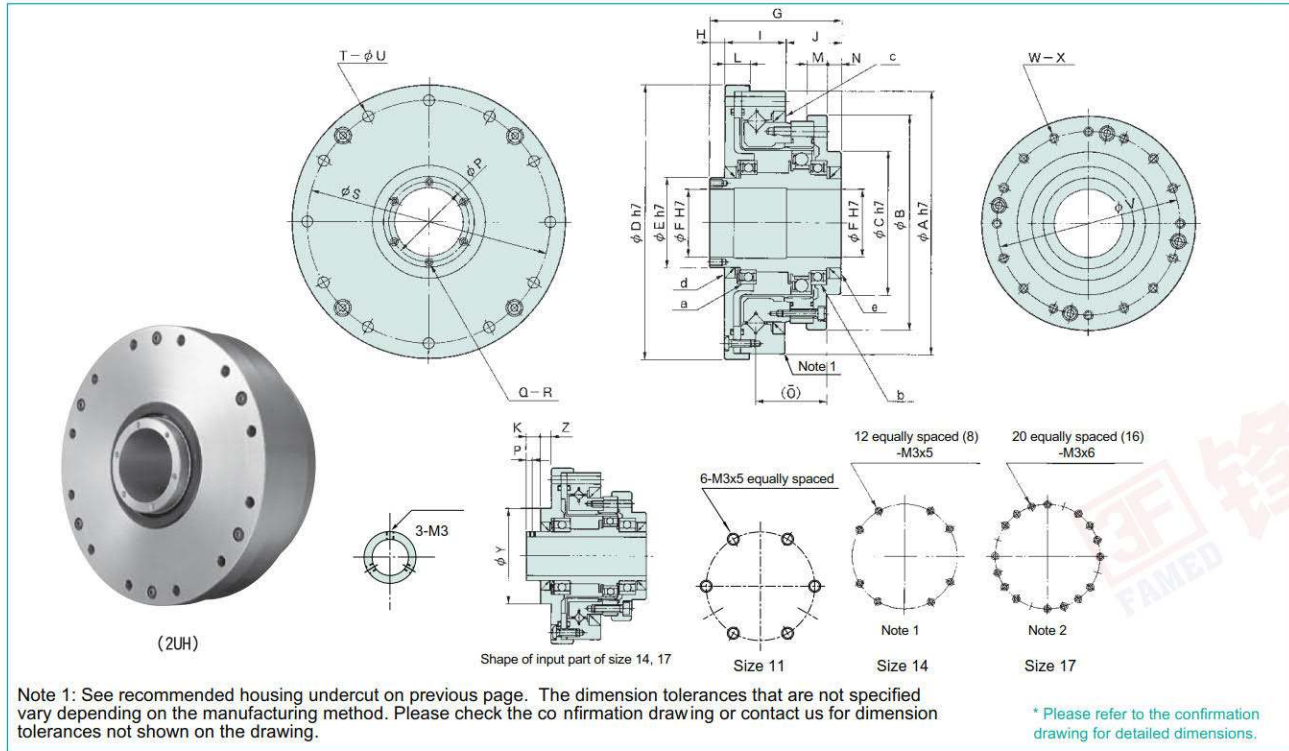

Dimensions (2UH)

Table 241-1 Unit: mm

Symbol	Size	11	14	17	20	25	32	40	45	50	58	65
φ A h7	SHG/SHF Series	62	70	80	90	110	142	170	190	214	240	276
	SHG/SHF-LW Series	45.3	54	64	75	90	115	140	160	175	201	221
φ B	SHG/SHF Series	—	52	62	73	88	115	140	160	168	195	213
	SHG/SHF-LW Series	—	11.5	12	13.5	15.5	20.5	25	27	30	35	42.5
φ C h7		30.5	36	45	50	60	85	100	120	130	150	160
φ D h7		64	74	84	95	115	147	175	195	220	246	284
φ E h7		18	20	25	30	38	45	59	64	74	84	96
φ F H7		14	14	19	21	29	36	46	52	60	70	80
G		48	52.5	56.5	51.5	55.5	65.5	79	85	93	106	128
H		14	12	12	5	6	7	8	8	9	10	14
I		19	20.5	23	25	26	32	38	42	45	52	56.5
J		15	20	21.5	21.5	23.5	26.5	33	35	39	44	57.5
K		6.5	6.5	6.5	—	—	—	—	—	—	—	—
L		8	9	10	10.5	10.5	12	14	15	16	17	18
M	SHG/SHF Series	6.5	8	8.5	9	8.5	9.5	13	12	12	15	19.5
	SHG/SHF-LW Series	—	11.5	12	13.5	15.5	20.5	25	27	30	35	42.5
N		6.5	7.5	8.5	7	6	5	7	7	7	7	12
O		17.5	21.7	23.9	25.5	29.6	36.4	44	47.5	52.5	62.2	72
φ P (P)		—	(2.5)	(2.5)	25.5	33.5	40.5	52	58	67	77	88
Q		—	3	3	6	6	6	6	6	6	8	6
R		—	M3	M3	M3×6	M3×6	M3×6	M4×8	M4×8	M4×8	M4×8	M5×10
φ S		56.4	64	74	84	102	132	158	180	200	226	258
T		4	8	12	12	12	12	18	12	16	16	16
φ U		3.5	3.5	3.5	3.5	4.5	5.5	6.6	6.6	9	9	11
φ V		37	44	54	62	77	100	122	140	154	178	195
W		6	12 E. A. 8	20 E. A. 16	16	16	16	12	16	16	12	16
X	SHG/SHF Series	M3X5	M3×5	M3×6	M3×6	M4×7	M5×8	M6×10	M8×10	M8×11	M10×15	M10×15
	SHG/SHF-LW Series	—	M3×5	M3×6	M3×6	M4×7	M5×8	M6×10	M8×10	M8×11	M10×15	M10×15
φ Y		36	36	45	—	—	—	—	—	—	—	—
Z		7.5	5.5	5.5	—	—	—	—	—	—	—	—
a	SHG/SHF Series	6804 ZZ	6804 ZZ	6805 ZZ	6806 ZZ	6808 ZZ	6809 ZZ	6912 ZZ	6913 ZZ	6915 ZZ	6917 ZZ	6920 ZZ
	SHG/SHF-LW Series	6704 ZZ	6804 ZZ	6805 ZZ	6806 ZZ	6808 ZZ	6809 ZZ	6812 ZZ	6813 ZZ	6815 ZZ	6817 ZZ	6820 ZZ
b	SHG/SHF Series	—	6804 ZZ	6805 ZZ	6806 ZZ	6808 ZZ	6809 ZZ	6812 ZZ	6813 ZZ	6815 ZZ	6817 ZZ	6820 ZZ
	SHG/SHF-LW Series	—	6804 ZZ	6805 ZZ	6806 ZZ	6808 ZZ	6809 ZZ	6812 ZZ	6813 ZZ	6815 ZZ	6817 ZZ	6820 ZZ
c	SHG/SHF Series	D41.950.95	D49585	D59685	D69785	D84945	D1101226	D1321467	D1521707	D1681868	D1932129	D21623811
	SHG/SHF-LW Series	S18274	S20304.5	S25356	S30405	S38475	S45607	S60789	S658510	S759510	S8511012	S10012513
d	SHG/SHF Series	—	S20304.5	S25356	S30405	S38475	S45607	S60789	S658510	S759510	S8511012	S10012513
	SHG/SHF-LW Series	—	S20304.5	S25356	S30405	S38475	S45607	S60789	S658510	S759510	S8511012	S10012513
e	SHG/SHF Series	S18274	S20304.5	S25356	S30405	S38475	S45607	S60789	S658510	S759510	S8511012	S961128
	SHG/SHF-LW Series	—	S20304.5	S25356	S30405	S38475	S45607	S60789	S658510	S759510	S8511012	S961128

Mass (2UH)

Table 242-1 Unit: kg

Symbol	Size	11	14	17	20	25	32	40	45	50	58	65
2UH		0.53	0.71	1.00	1.38	2.1	4.5	7.7	10.0	14.5	20.0	28.5
2UH-LW (Lightweight)		—	0.55	0.8	1.1	1.6	3.6	6.2	8	11.8	16.4	23.3

Moment of Inertia (2UH)

Table 242-2

Symbol	Size	11	14	17	20	25	32	40	45	50	58	65
Moment of inertia	I × 10 ⁻⁴ kgm ²	0.080	0.091	0.193	0.404	1.070	2.85	9.28	13.8	25.2	49.5	94.1
	J × 10 ⁻⁶ kgfms ²	0.082	0.093	0.197	0.412	1.090	2.91	9.47	14.1	25.7	50.5	96.0

Starting torque (2UH)

See "Engineering data" for a description of terms. Please use as reference values; the values vary based on use conditions.

Table 242-3 Unit: Ncm

Ratio	Size	11	14	17	20	25	32	40	45	50	58	65
30		—	11	30	43	64	112	—	—	—	—	—
50		7.1	8.8	27	36	56	85	136	165	216	297	—
80		—	7.5	25	33	50	74	117	138	179	244	314
100		5.9	6.9	24	32	49	72	112	131	171	231	297
120		—	—	24	31	48	68	110	126	165	223	287
160		—	—	—	31	47	67	105	122	156	213	276

Backdriving torque (2UH)

See "Engineering data" for a description of terms. Please use as reference values; the values vary based on use conditions.

Table 242-4 Unit: Nm

Ratio	Size	11	14	17	20	25	32	40	45	50	58	65
30		—	5.4	17	23	35	57	—	—	—	—	—
50		4.6	5.3	16	22	34	51	82	99	129	178	—
80		—	7.2	24	31	48	70	112	133	172	234	301
100		7.6	8.2	29	38	59	86	134	158	205	278	356
120		—	—	34	45	69	97	158	182	237	322	413
160		—	—	—	59	90	128	201	233	299	408	530

Continuous Operating Time (2UH)

Continuous operating time

Table 246-2

Size	Operating time	Continuous operating time at no-load operation (min)	Continuous operating time at the rated load (min)
11		90	60
14		90	60
17		90	60
20		90	60
25		60	45
32		45	35
40		40	30
45		35	25
50		30	20
58		20	15
65		15	10

* Contact us as the continuous operating time may vary significantly depending on the operating condition.

The internal temperature rises due to the effect of the oil seal and the supporting bearing used for the input shaft (high-speed rotation side) for SHF-2UH. Observe the operating time shown in Table 246-2 for continuous operation.

The operating time shown in Table 246-2 is calculated based on the time required for the temperature inside the unit to rise to 80°C and for the oil seal temperature to rise to 100°C. Take care not to exceed the temperature given above in conducting continuous operation. The following review will be necessary if the temperature exceeds the value given above.

- Change of timing to replace lubricant
- Change of lubricant
- Measures against lubricant leakage accompanied by the pressure rise inside the unit
- Measures against deterioration due to heat on the oil seal area

Performance Data for the Input Bearing for Hollow Shaft (2UH)

The internal temperature rises due to the effect of the oil seal and the supporting bearing used for the input shaft (high-speed rotation side) for SHF-2UH. Observe the operating time shown in Table 246-2 for continuous operation. The operating time shown in Table 246-2 is calculated based on the time required for the temperature inside the unit to rise to 80°C and for the oil seal temperature to rise to 100°C. Take care not to exceed the temperature given above in conducting continuous operation. The following review will be necessary if the temperature exceeds the value given above. Contact us in such an event.

Input bearing specifications

Size	Bearing A			Bearing B			a	b	Maximum radial load
	Model	Basic dynamic rated load Cr (N)	Basic static rated load Cor (N)	Model	Basic dynamic rated load Cr (N)	Basic static rated load Cor (N)			
11	6804ZZ	4000	2470	6704ZZ	1400	720	25.7	15.5	—
14	6804ZZ	4000	2470	6804ZZ	4000	2470	27	16.5	230
17	6805ZZ	4300	2950	6805ZZ	4300	2950	29	17.5	250
20	6806ZZ	4500	3450	6806ZZ	4500	3450	27	15.5	275
25	6808ZZ	4900	4350	6808ZZ	4900	4350	29.5	16.5	250
32	6909ZZ	14100	10900	6809ZZ	5350	5250	33	23	770
40	6912ZZ	19400	16300	6812ZZ	11500	10900	39.5	27.5	1060
45	6913ZZ	17400	16100	6813ZZ	11900	12100	44	28.5	900
50	6915ZZ	24400	22600	6815ZZ	12500	13900	49	31.5	1370
58	6917ZZ	32000	29600	6817ZZ	18700	20000	56.2	36.5	1720
65	6920ZZ	42500	36500	6820ZZ	19600	21200	67	44.5	2300

Table 247-1 Fig 247-1

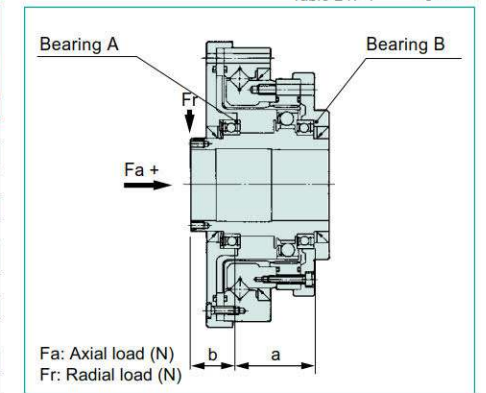

Outline Dimensions (2UJ)

Outline Dimensions (2UJ)

You can download the CAD files from our website: harmonicdrive.net

Fig. 248-1

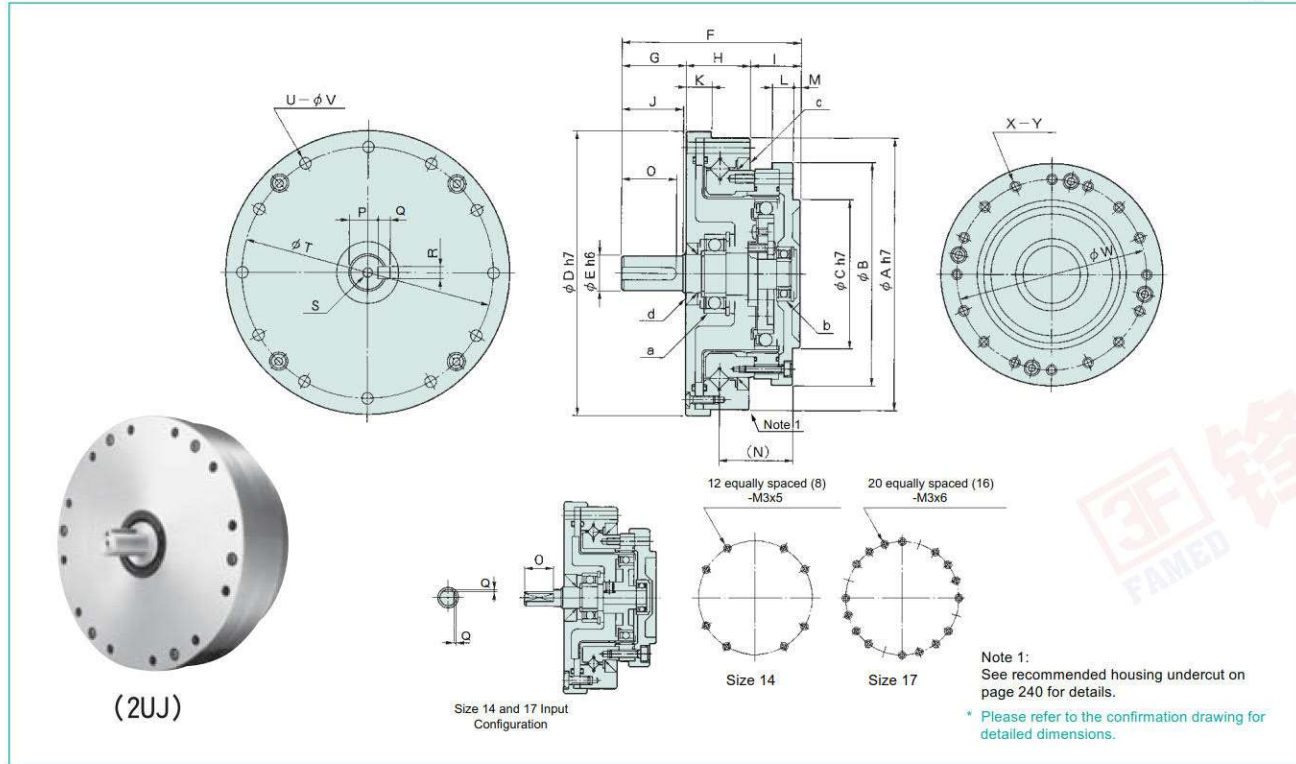

Dimensions (2UJ)

Table 248-1 Unit: mm

Symbol	Size	14	17	20	25	32	40	45	50	58	65
φA h7		70	80	90	110	142	170	190	214	240	276
φB		54	64	75	90	115	140	160	175	201	221
φC h7		36	45	50	60	85	100	120	130	150	160
φD h7		74	84	95	115	147	175	195	220	246	284
φE h6		6	8	10	14	14	16	19	22	22	25
F		50.5	56	63.5	72.5	84.5	100	108	121	133	156
G		15	17	21	26	26	31	31	37	37	42
H		20.5	23	25	26	32	38	42	45	52	56.5
I		15	16	17.5	20.5	26.5	31	35	39	44	57.5
J		14	16	20	25	25	30	30	35	35	40
K		9	10	10.5	10.5	12	14	15	16	17	18
L		8	8.5	9	8.5	9.5	13	12	12	15	19.5
M		2.5	3	3	3	5	5	7	7	7	12
N		21.7	23.9	25.5	29.6	36.4	44	47.5	52.5	62.2	72
O		11	12	16.5	22.5	22.5	27.5	28	33	33	39
P		—	—	8.2 \pm 0.1	11 \pm 0.1	11 \pm 0.1	13 \pm 0.1	15.5 \pm 0.1	18.5 \pm 0.1	18.5 \pm 0.1	21 \pm 0.1
Q		0.5	0.5	3 \pm 0.025	5 \pm 0.030	5 \pm 0.030	5 \pm 0.030	6 \pm 0.030	6 \pm 0.030	6 \pm 0.030	7 \pm 0.036
R		—	—	3 \pm 0.025	5 \pm 0.030	5 \pm 0.030	5 \pm 0.030	6 \pm 0.030	6 \pm 0.030	6 \pm 0.030	8 \pm 0.036
S		—	—	M3×6	M5×10	M5×10	M5×10	M6×12	M6×12	M6×12	M8×16
φT		64	74	84	102	132	158	180	200	226	258
U		8	12	12	12	12	12	18	12	16	16
φV		3.5	3.5	3.5	4.5	5.5	6.6	6.6	9	9	11
φW		44	54	62	77	100	122	140	154	178	195
X		12 E. A. 8	20 E. A. 16	16	16	16	16	12	16	12	16
Y		M3×5	M3×6	M3×6	M4×7	M5×8	M6×10	M8×10	M8×11	M10×15	M10×15
		φ3.5×11.5	φ3.5×12	φ3.5×13.5	φ4.5×15.5	φ5.5×20.5	φ6.6×25	φ9×28	φ9×30	φ11×35	φ11×42.5
a		698 ZZ	6900 ZZ	6902 ZZ	6002 ZZ	6004 ZZ	6006 ZZ	6206 ZZ	6207 ZZ	6208 ZZ	6209 ZZ
b		695 ZZ	697 ZZ	698 ZZ	6900 ZZ	6902 ZZ	6003 ZZ	6004 ZZ	6005 ZZ	6006 ZZ	6007 ZZ
c		D49585	D59685	D69785	D84945	D1101226	D1321467	D1521707	D1681868	D1932129	D21623811
d		G8184	D10205	D15255	D15255	D20355	D30457	D30457	D35557	D40607	D45607

Mass (2UJ)

Table 249-1 Unit: kg

Symbol	Size	14	17	20	25	32	40	45	50	58	65
Mass (kg)		0.66	0.94	1.38	2.1	4.4	7.3	9.8	13.9	19.4	26.5

Moment of Inertia (2UJ)

Table 249-2

Symbol	Size	14	17	20	25	32	40	45	50	58	65
Moment of inertia	I $\times 10^{-4}$ kgm ²	0.025	0.059	0.137	0.320	1.20	3.41	5.80	9.95	20.5	35.5
	J $\times 10^{-4}$ kgfms ²	0.026	0.060	0.140	0.327	1.22	3.48	5.92	10.2	20.9	36.2

Starting torque (2UJ)

See "Engineering data" for a description of terms. Please use the values vary based on use conditions. as reference values;

Table 249-3 Unit: Ncm

Ratio	Size	14	17	20	25	32	40	45	50	58	65
30		6.8	11	19	26	63	—	—	—	—	—
50		5.7	9.7	14	22	41	72	94	125	178	—
80		4.4	7.2	11	15	29	52	68	88	125	163
100		3.7	6.5	9.9	14	27	47	60	80	113	147
120		—	6.2	9.3	13	24	44	55	74	105	137
160		—	—	8.6	12	23	39	50	66	94	122

Backdriving torque (2UJ)

See "Engineering data" for a description of terms. Please use as reference values; the values vary based on use conditions.

Table 249-4 Unit: Nm

Ratio	Size	14	17	20	25	32	40	45	50	58	65
30		3.5	5.9	10	16	31	—	—	—	—	—
50		3.4	5.8	8.4	13	25	43	56	75	107	—
80		4.2	6.9	10	15	28	50	65	85	120	154
100		4.5	7.8	12	17	33	56	72	96	135	176
120		—	8.9	13	19	34	63	79	106	151	198
160		—	—	17	23	43	75	96	126	181	235

Performance Data for the Input bearing (2UJ)

The input shaft of the 2UJ is supported by two single-row deep-groove bearings. For peak performance of the SHF-2UJ it is essential that the following Specification for Input Bearing be observed -Figure 254-1 shows the points of application of forces. See Table 254-1 for the dimensions (a) and (b). Graphs 254-1 and 254-2 show the Maximum Allowable Radial and Axial Loads. The values in Graph 254-1 and 254-2 are based on an average input speed of 2,000 rpm and a mean bearing life of L10=7,000h.

Example: If the input shaft of a SHF-40-2UJ unit is subjected to an axial load (Fa) of 500 N. The maximum allowable radial force will be 400 N.

Input bearing specifications

Table 254-1

Size	Bearing A		Bearing B		a	b	Maximum radial load	
	Model	Basic dynamic rated load	Basic static rated load	Model				Basic dynamic rated load
14	698ZZ	2240	910	695ZZ	1080	430	20	110
17	6900ZZ	2700	1270	697ZZ	1610	710	23.5	135
20	6902ZZ	4350	2260	698ZZ	2240	910	26.5	210
25	6002ZZ	5600	2830	6900ZZ	2700	1270	28	270
32	6004ZZ	9400	5000	6902ZZ	4350	2260	36	490
40	6006ZZ	13200	8300	6003ZZ	6000	3250	43	660
45	6206ZZ	19500	11300	6004ZZ	9400	5000	47.5	1030
50	6207ZZ	25700	15300	6005ZZ	10100	5850	53	1330
58	6208ZZ	29100	17800	6006ZZ	13200	8300	62.5	1600
65	6209ZZ	32500	20500	6007ZZ	16000	10300	79	1650

Fig. 255-1

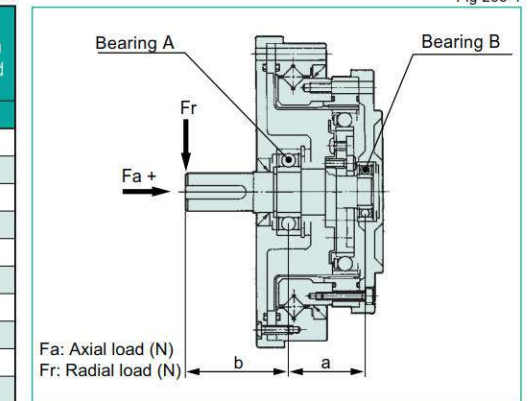

Outline Dimensions(2SO、 2SH)

Outline Dimensions (2SO)

You can download the CAD files from our website: harmonicdrive.net

Fig. 255-1

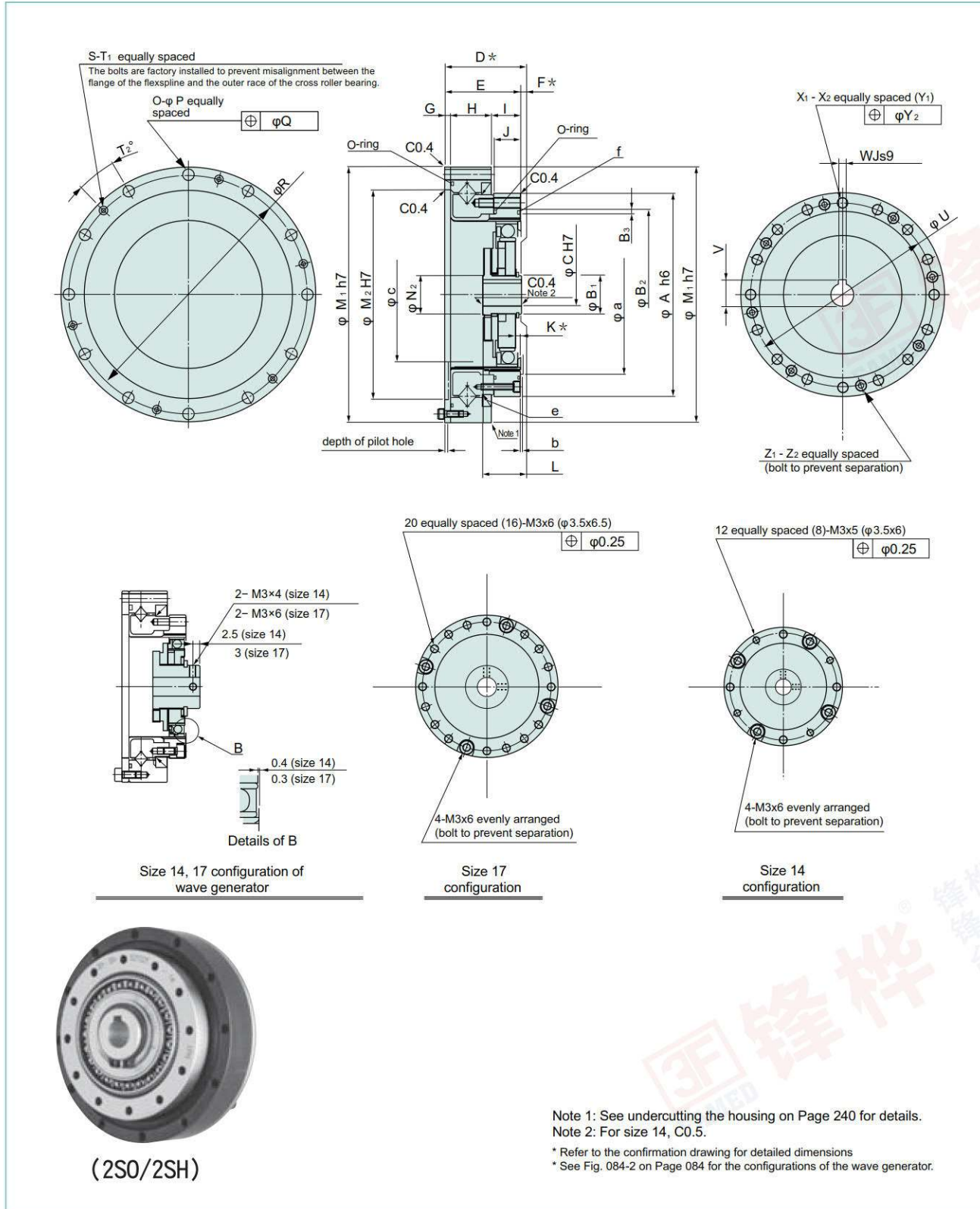

Dimensions (2SO)

Table 256-1
Unit : mm

Symbol	SIZE	14	17	20	25	32	40	45	50	58	65
φA h6		50	60	70	85	110	135	155	170	195	215
φB ₁		14	18	21	26	26	32	32	32	40	48
φB ₂		—	—	—	—	—	—	128	141	163	180.4
φB ₃		—	—	—	—	—	—	2.7	2.7	2.7	2.7
φC	Standard (H7)	6	8	9	11	14	14	19	19	22	24
	Max. dimen.	8	10	13	15	15	20	20	20	25	30
D*	SHF Series	28.5 ^{+0.08}	32.5 ^{+0.09}	33.5 ^{+0.10}	37 ^{+0.11}	44 ^{+0.11}	53 ^{+0.11}	58 ^{+0.12}	64 ^{+0.13}	75.5 ^{+0.13}	—
	SHG Series	28.5 ^{+0.04}	32.5 ^{+0.04}	33.5 ^{+0.04}	37 ^{+0.05}	44 ^{+0.06}	53 ^{+0.06}	58 ^{+0.06}	64 ^{+0.07}	75.5 ^{+0.07}	83 ^{+0.07}
E		23.5	26.5	29	34	42	51	56.5	63	73	81.5
F*		5	6	4.5	3	2	2	1.5	1	2.5	1.5
G		2.4	3	3	3.3	3.6	4	4.5	5	5.8	6.5
H		14.1	16	17.5	18.7	23.4	29	32	34	40.2	43
I		7	7.5	8.5	12	15	18	20	24	27	32
J		6	6.5	7.5	10	14	17	19	22	25	29
K*	SHF Series	0.4	0.3	0.1	2.1	2.5	3.3	3.7	4.2	4.8	—
	SHG Series	1.4	1.6	1.5	3.5	4.2	5.6	6.3	7	8.2	9.5
L	SHF Series	17.6 ^{+0.1}	19.5 ^{+0.1}	20.1 ^{+0.1}	20.2 ^{+0.1}	22 ^{+0.1}	27.5 ^{+0.1}	27.9 ^{+0.1}	32 ^{+0.1}	34.9 ^{+0.1}	—
	SHG Series	18.5 ^{+0.1}	20.7 ^{+0.1}	21.5 ^{+0.1}	21.6 ^{+0.1}	23.6 ^{+0.1}	29.7 ^{+0.1}	30.5 ^{+0.1}	34.8 ^{+0.1}	38.3 ^{+0.1}	44.6 ^{+0.1}
φM ₁ h7		70	80	90	110	142	170	190	214	240	276
φM ₂ H7		48	60	70	88	114	140	158	175	203	232
φN ₂		—	—	—	—	—	32	—	32	—	48
O		8	12	12	12	12	12	18	12	16	16
φP		3.5	3.5	3.5	4.5	5.5	6.6	6.6	9	9	11
φQ		0.25	0.25	0.25	0.25	0.25	0.3	0.3	0.5	0.5	0.5
φR		64	74	84	102	132	158	180	200	226	258
S		2	4	4	4	4	6	6	6	8	8
T ₁		M3×6	M3×6	M3×8	M3×8	M4×8	M4×10	M4×8	M5×12	M5×12	M6×16
T ₂ (angle)		22.5°	15°	15°	15°	15°	15°	10°	15°	11.25°	11.25°
φU		44	54	62	77	100	122	140	154	178	195
V		—	—	10.4	12.8	16.3	16.3	21.8	21.8	24.8	27.3
W Js9		—	—	3	4	5	5	6	6	6	8
X ₁		12 E. A. 8	12 E. A. 16	16	16	16	16	12	16	12	16
X ₂		M3×5	M3×6	M3×6	M4×7	M5×8	M6×10	M8×10	M8×11	M10×15	M10×15
Y ₁		φ3.5×6	φ3.5×6.5	φ3.5×7.5	φ4.5×10	φ5.5×14	φ6.6×17	φ9×19	φ9×22	φ11×25	φ11×29
Y ₂		0.25	0.25	0.25	0.25	0.25	0.3	0.5	0.5	0.5	0.5
Z ₁		4	4	4	4	4	4	4	8	6	8
Z ₂		M3×6	M3×6	M3×8	M3×10	M4×16	M5×20	M5×20	M5×25	M6×25	M6×30
Minimum housing clearance	φa	38	45	53	66	86	106	119	133	154	172
	b	1	1	1.5	1.5	1.5	2	2	2	2.5	2.5
	φc	31	38	45	56	73	90	101	113	131	150
	d	1.7	2.1	2	2	2	2	2.3	2.5	2.9	3.5
	e	D49585	D59685	D69785	D84945	D1101226	D1321467	D1521707	D1681868	D1932129	D21623811
f	—	—	—	—	—	—	d1 121.5 d2 2.0	S135	d1 157.0 d2 2.0	S175	

● The following dimensions can be modified to accommodate customer-specific requirements.

Wave Generator : C
 Flexspline : O and P
 Circular Spline : X1 and X2

- The D, F and K values indicate relative position of individual gearing components (wave generator, flexpline, circular spline). Please strictly adhere to these values when designing your housing and mating parts.
- Please note that the circular spline face of sizes 14 through 40 does not incorporate an O-ring groove. Please provide alternate sealing arrangements.
- Due to the deformation of the Flexspline during operation, it is necessary to provide a minimum housing clearance, dimensions φa, b, c.

Wave generator is removed when the product is delivered.

Mass (2SO)

Table 256-2
Unit : kg

Symbol	Size	14	17	20	25	32	40	45	50	58	65
Mass (kg)		0.41	0.57	0.81	1.31	2.94	5.1	6.5	9.6	13.5	19.5

Mass (2SH)

Table 259-1
Unit: kg

Symbol	Size	14	17	20	25	32	40	45	50	58	65
Mass		0.45	0.63	0.89	1.44	3.1	5.4	6.9	10.2	14.1	20.9

Lubrication

Standard lubrication for SHG/SHF series is grease.
See "Engineering data" on Page 016 for details of the lubricant.

Application guide

As the gear unit is shipped with the outer race of the cross roller bearing and the flexspline temporarily bolted together, grease is not applied other than the gear teeth. Refer to the following application guide for grease application instructions

Application guide

Table 259-1

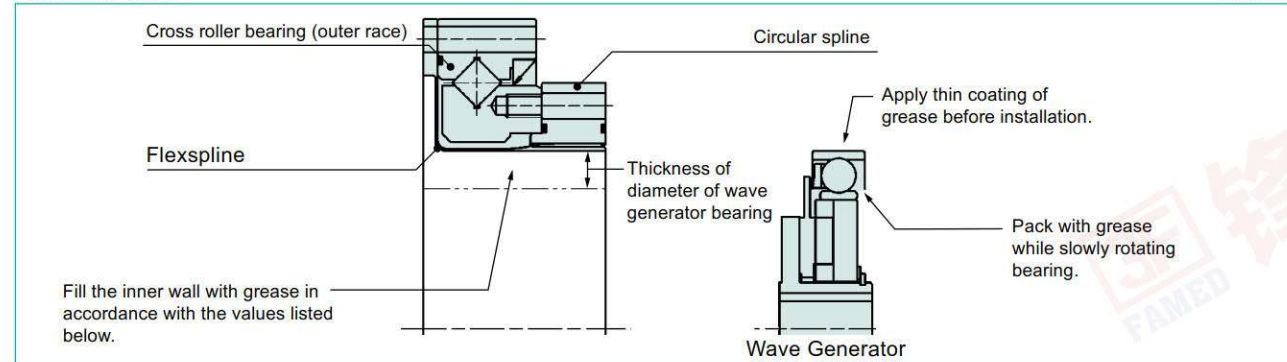

Application quantity

Table 259-2
Unit: g

Application	Size	14	17	20	25	32	40	45	50	58	65
Horizontal use		5.8	11	18	32	64	120	185	235	385	495
Vertical use	Output shaft facing up	7.5	13	19	37	74	130	200	255	400	530
	Output shaft facing down	8.9	15	22	42	84	150	230	290	480	630

Installation accuracy

Maintain the recommended tolerances shown in Figure 260-1 and Table 260-1 for peak performance.

Fig. 260-1

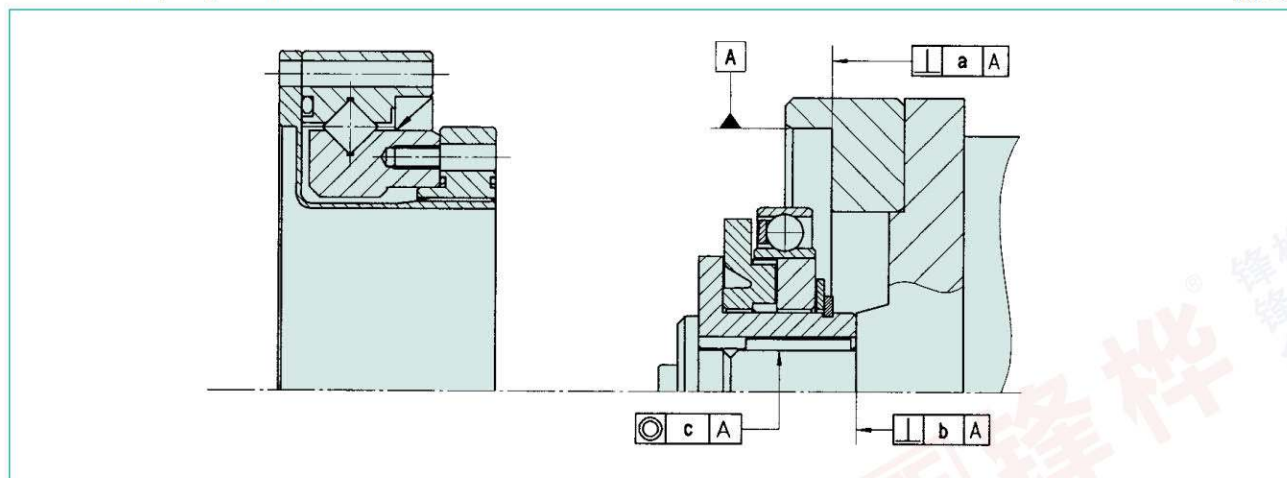

Unit: mm

Size	14	17	20	25	32	40	45	50	58
a	0.011	0.015	0.017	0.024	0.026	0.026	0.027	0.028	0.031
b	0.017	0.020	0.020	0.024	0.024	0.024	0.032	0.032	0.032
	(0.008)	(0.010)	(0.010)	(0.012)	(0.012)	(0.012)	(0.012)	(0.015)	(0.015)
c	0.030	0.034	0.044	0.047	0.047	0.050	0.063	0.066	0.068
	(0.016)	(0.018)	(0.019)	(0.022)	(0.022)	(0.022)	(0.024)	(0.030)	(0.033)

* The value in the parentheses indicates that Wave Generator does not have an Oldham coupling.

Installation Recommendations

Installation sequence

The wave generator is installed after the flexspline and circular spline. If the wave generator is not inserted into the flexspline last, gear teeth scuffing damage or improper eccentric gear mesh may result. Installation resulting in an eccentric tooth mesh (Dedoidal) will cause noise and vibration, and can lead to early failure of the gear. For proper function, the teeth of the flexspline and Circular Spline mesh symmetrically.

Assembly order for basic three elements

Fig. 260-2

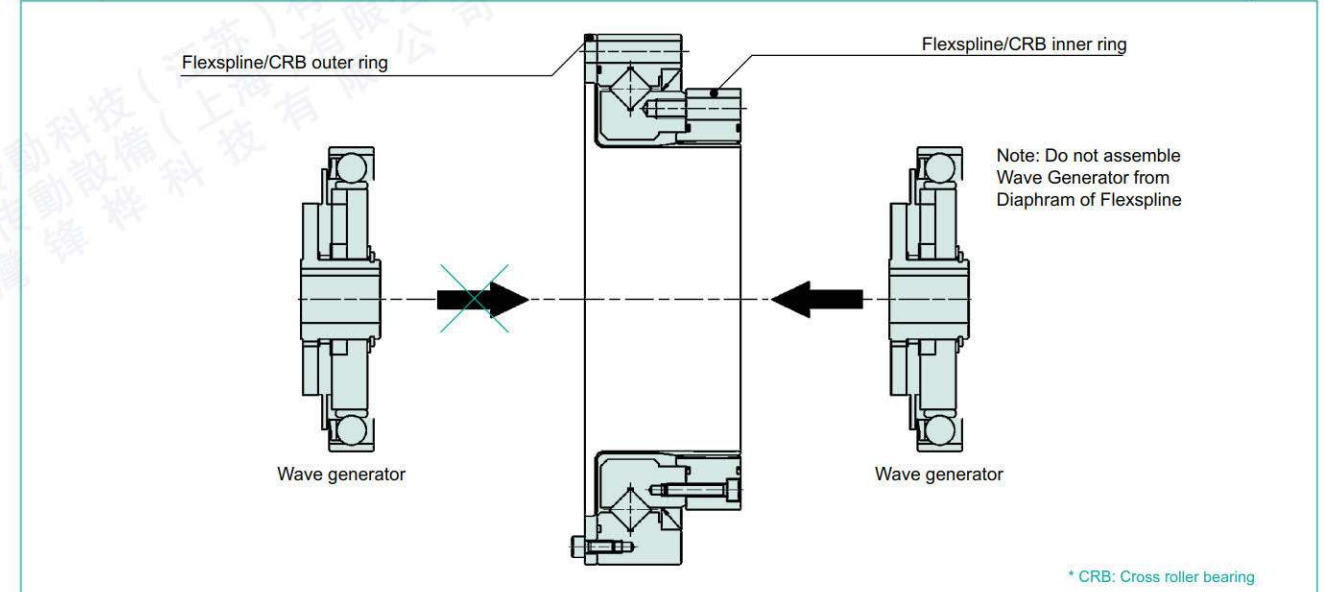

Precautions on assembly

It is extremely important to assemble the gear accurately and in proper sequence. For each of the three components, utilize the following precautions.

Wave generator

1. Avoid applying undue axial force to the wave generator during installation. Rotating the wave generator bearing while inserting it is recommended and will ease the process.
2. Extra care must be given to ensure that concentricity and inclination are within the specified limits (see page 253).
3. Installation bolts on the Wave Generator and Flexspline should not interfere each other.

Circular spline

The circular Spline must not be deformed in any way during the assembly. It is particularly important that the mounting surfaces are prepared correctly.

1. Mounting surfaces need to have adequate flatness, smoothness, and no distortion.
2. Especially in the area of the screw holes, burrs or foreign matter should not be present.
3. Adequate relief in the housing corners is needed to prevent interference with the corner of the circular spline.
4. The circular spline should be rotatable within the housing. Be sure there is not interference and that it does not catch on anything.
5. Bolts should not rotate freely when tightening and should not have any irregularity due to the bolt hole being misaligned or oblique.
6. Do not tighten the bolts with the specified torque all at once. Tighten the bolts temporarily with about half the specified torque, and then tighten them with the specified torque. Tighten them in an even, crisscross pattern.
7. Avoid pinning the circular spline if possible as it can reduce the rotational precision and smoothness of operation.

Flexspline

1. Mounting surfaces need to have adequate flatness, smoothness, and no distortion.
2. Especially in the area of the screw holes, burrs or foreign matter should not be present.
3. Adequate clearance with the housing is needed to ensure no interference especially with the major axis of flexspline
4. Bolts should rotate freely when installing through the mounting holes of the flexspline and should not have any irregularity due to the shaft bolt holes being misaligned or oblique.
5. Do not tighten the bolts with the specified torque all at once. Tighten the bolts temporarily with about half the specified torque, and then tighten them to the specified torque. Tighten them in an even, crisscross pattern.
6. The flexspline and circular spline are concentric after assembly. After installing the wave generator bearing, if it rotates in unbalanced way, check the mounting for dedoidal or non-concentric installation.
7. Care should be taken not to damage the flexspline diaphragm or gear teeth during assembly.
Avoid hitting the tips of the flexspline teeth and circular spline teeth. Avoid installing the CS from the open side of the flexspline after the wave generator has been installed.

Rust prevention

Although Harmonic Drive® gears come with some corrosion protection, the gear can rust if exposed to the environment. The gear external surfaces typically have only a temporary corrosion inhibitor and some oil applied. If an anti-rust product is needed, please contact us to review the options.

Features

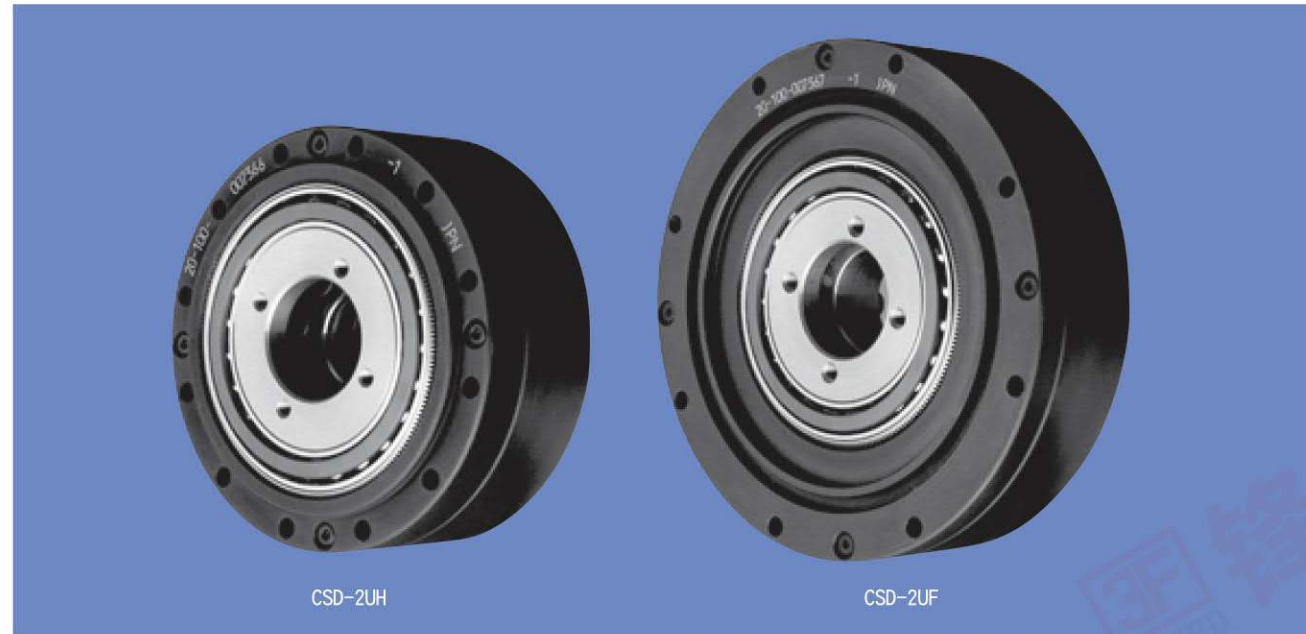

CSD Gear Units

Available in two form factors, the CSD series gear units offer zero backlash while remaining lightweight and compact. These units are ideal for humanoid robots, aerospace, semiconductor equipment and many other critical applications. Ratios available are from 50:1 to 160:1.

Features

- Zero backlash
- Compact design
- Hollow shaft (2UF only)
- High-load capacity
- Lightweight

Structure of CSD Gear Unit

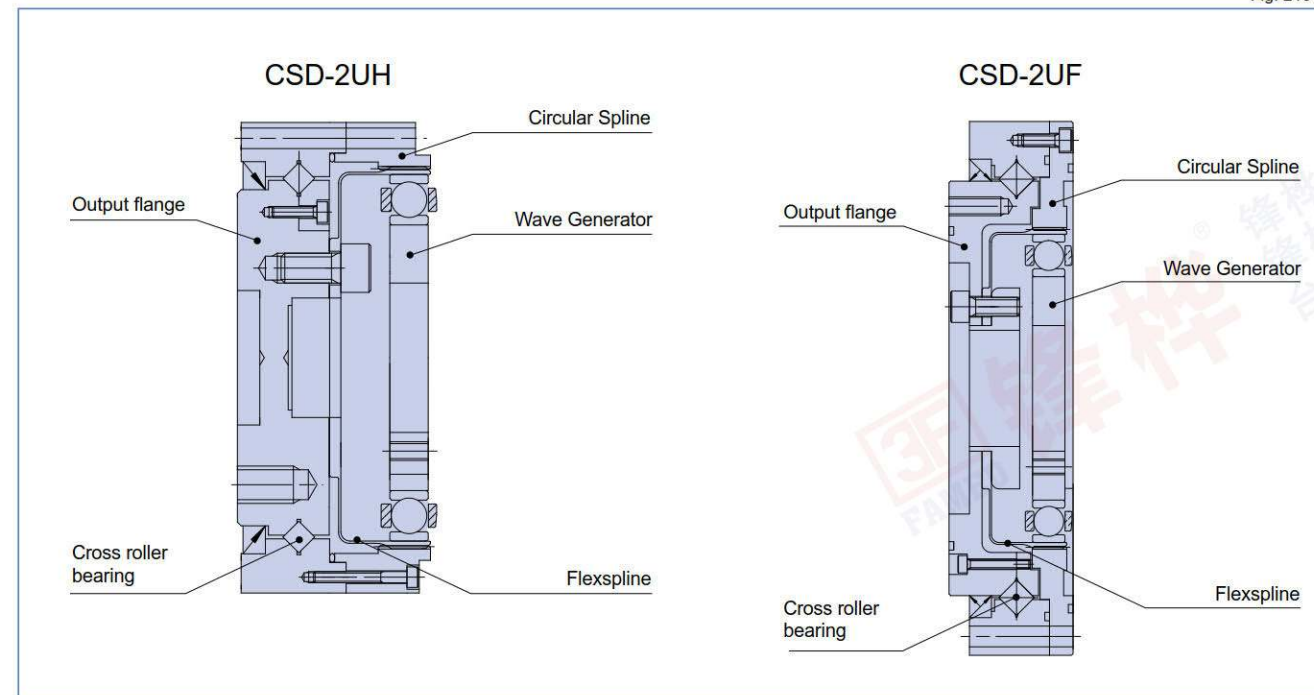

Ordering Code

CSD - 20 - 100 - 2UH - SP

Series	Size	Ratio*				Model	Special specification
CSD	14	50	100	—	2UH= Unit type (Size 14 to 50) 2UF= Hollow shaft (Size 14 to 40)	Blank= Standard product SP = Special specification code	
	17	50	100	—			
	20	50	100	160			
	25	50	100	160			
	32	50	100	160			
	40	50	100	160			
	50	50	100	160			

* The reduction ratio value is based on the following configuration: Input: wave generator, fixed: circular spline, output: flexspline

Technical Data

Rating table

■ CSD-2UH

Size	Ratio	Rated Torque at 2000rpm		Limit for Repeated Peak Torque		Limit for Average Torque		Limit for Momentary Peak Torque		Maximum Input Speed (rpm) Grease lubricant	Limit for Average Input Speed (rpm) Grease lubricant	Moment of Inertia	
		Nm	kgfm	Nm	kgfm	Nm	kgfm	Nm	kgfm			$I (\times 10^{-4} \text{kgm}^2)$	$J (\times 10^{-4} \text{kgms}^{-2})$
14	50	3.7	0.38	12	1.2	4.8	0.49	24	2.4	8500	3500	0.021	0.021
	100	5.4	0.55	19	1.9	7.7	0.79	35	3.6				
17	50	11	1.1	23	2.3	18	1.9	48	4.9	7300	3500	0.054	0.055
	100	16	1.6	37	3.8	27	2.8	71	7.2				
20	50	17	1.7	39	4.0	24	2.4	69	7.0	6500	3500	0.090	0.092
	100	28	2.9	57	5.8	34	3.5	95	9.7				
	160	28	2.9	64	6.5	34	3.5	95	9.7				
25	50	27	2.8	69	7.0	38	3.9	127	13	5600	3500	0.282	0.288
	100	47	4.8	110	11	75	7.6	184	19				
	160	47	4.8	123	13	75	7.6	204	21				
32	50	53	5.4	151	15	75	7.6	268	27	4800	3500	1.09	1.11
	100	96	10	233	24	151	15	420	43				
	160	96	10	261	27	151	15	445	45				
40	50	96	10	281	29	137	14	480	49	4000	3000	2.85	2.91
	100	185	19	398	41	260	27	700	71				
	160	206	21	453	46	316	32	765	78				
50	50	172	18	200	51	247	25	1000	102	3500	2500	8.61	8.78
	100	329	34	686	70	466	48	1440	147				
	160	370	38	823	84	590	60	1715	175				

(Note) Moment of inertia: $I = \frac{1}{4} GD^2$

■ CSD-2UF

Size	Ratio	Rated Torque at 2000rpm		Limit for Repeated Peak Torque		Limit for Average Torque		Limit for Momentary Peak Torque		Maximum Input Speed (rpm) Grease lubricant	Limit for Average Input Speed (rpm) Grease lubricant	Moment of Inertia	
		Nm	kgfm	Nm	kgfm	Nm	kgfm	Nm	kgfm			$I (\times 10^{-4} \text{kgm}^2)$	$J (\times 10^{-4} \text{kgms}^{-2})$
14	50	3.7	0.38	12	1.2	4.8	0.49	24	2.4	8500	3500	0.021	0.021
	100	5.4	0.55	19	1.9	7.7	0.79	35	3.6				
17	50	11	1.1	23	2.3	18	1.9	48	4.9	7300	3500	0.054	0.055
	100	16	1.6	37	3.8	27	2.8	71	7.2				
20	50	17	1.7	39	4.0	24	2.4	69	7.0	6500	3500	0.090	0.092
	100	28	2.9	57	5.8	34	3.5	95	9.7				
	160	28	2.9	64	6.5	34	3.5	95	9.7				
25	50	27	2.8	69	7.0	38	3.9	127	13	5600	3500	0.282	0.288
	100	47	4.8	110	11	75	7.6	184	19				
	160	47	4.8	123	13	75	7.6	204	21				
32	50	53	5.4	151	15	75	7.6	268	27	4800	3500	1.09	1.11
	100	96	10	233	24	151	15	420	43				
	160	96	10	261	27	151	15	445	45				
40	50	96	10	281	29	137	14	480	49	4000	3000	2.85	2.91
	100	185	19	398	41	260	27	700	71				
	160	206	21	453	46	316	32	765	78				

(Note) Moment of inertia: $I = \frac{1}{4} GD^2$

Outline dimensions CSD-2UH

Fig. 212-1

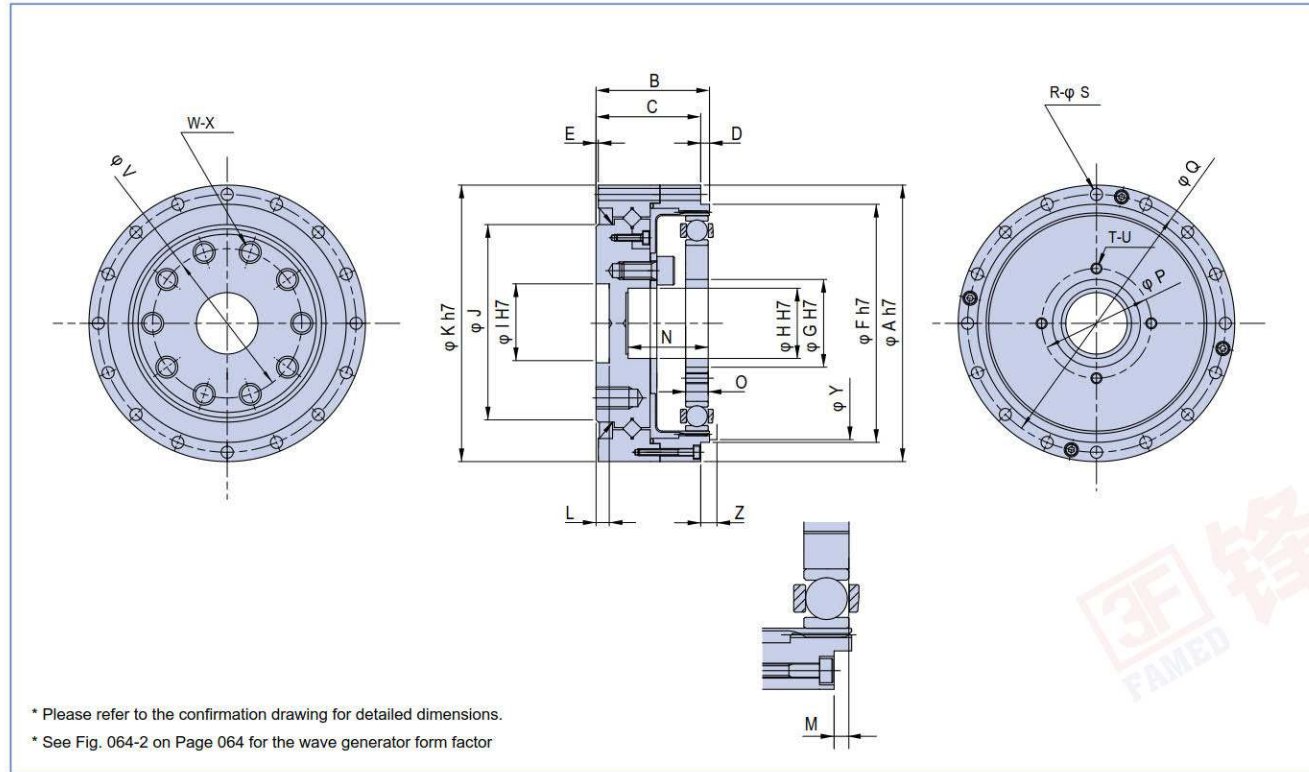

* Please refer to the confirmation drawing for detailed dimensions.
* See Fig. 064-2 on Page 064 for the wave generator form factor

Dimensions CSD-2UH

Table 212-1
Unit : mm

Symbol	Size	14	17	20	25	32	40	50
φA h7		55	62	70	85	112	126	157
B		25	26.5	29.7	37.1	43	51.7	62.5
C		23	24.5	27.7	34.1	40	47.7	58.5
D		2	2	2	3	3	4	4
E		0.5	0.5	0.5	0.5	1	1	1
φF h7		42.5	49.5	58	73	96	108.5	136
φG H7		11	15	20	24	32	40	50
φH H7		11	11	16	20	30	32	44
φI H7		12	14	18	24	32	36	48
φJ		31	38	45	58	78	90	112
φK h7		55	62	70	85	112	126	157
L		5	5	5	5.5	5.5	6	7
M		1.7 ^{+0.2}	1.7 ^{+0.2}	1.7 ^{+0.2}	2.6 ^{+0.2}	2.5 ^{+0.2}	3.4 ^{+0.2}	3.2 ^{+0.2}
N		14.8	16.3	18.8	23.7	30.6	36.5	44.3
O		4 ^{-0.1}	5 ^{-0.1}	5.2 ^{-0.1}	6.3 ^{-0.1}	8.6 ^{-0.1}	10.3 ^{-0.1}	12.7 ^{-0.1}
φP (PCD)		17	21	26	30	40	50	60
φQ (PCD)		49	56	64	79	104	117.5	147
R		6	10	12	18	18	18	22
φS		3.4	3.4	3.4	3.4	4.5	5.5	6.6
T		4	4	4	4	4	4	4
U		M3	M3	M3	M3	M4	M5	M6
φV (PCD)		25	27	34	42	57	72	88
W		10	8	8	8	10	10	10
X		M3×7	M5×8	M6×9	M8×12	M8×12	M10×15	M12×18
φY		38	45	53	66	86	106	133
Z		3	3	3.5	4.5	5	6.5	7.5
Mass (kg)		0.35	0.46	0.65	1.2	2.4	3.6	6.9

●由于零部件的制造方法（铸造、机械加工）不同，公差也存在差异。关于没有注明公差的尺寸，如需了解公差范围，请咨询本公司或授权代理商。

Outline dimensions CSD-2UF

Fig. 213-1

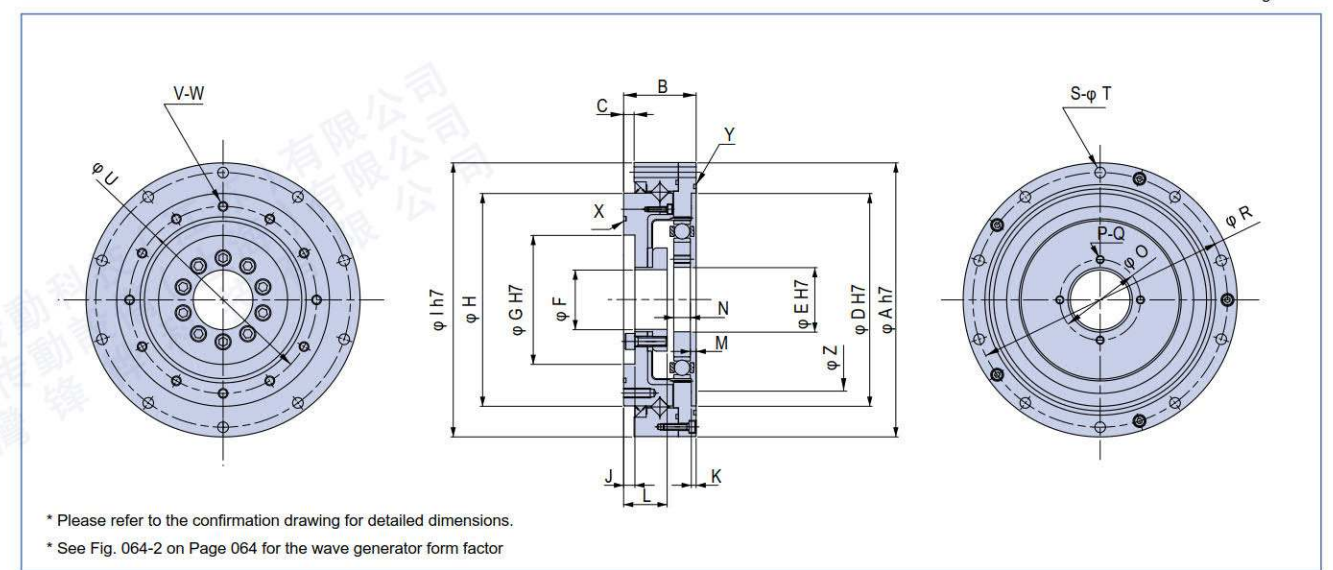

* Please refer to the confirmation drawing for detailed dimensions.
* See Fig. 064-2 on Page 064 for the wave generator form factor

Dimensions CSD-2UF

Table 213-1
Unit : mm

Symbol	Size	14	17	20	25	32	40
φA h7		70	80	90	110	142	170
B		22	22.7	26.8	31.5	37	45
C		0.5	0.5	2.3	2.1	2.8	6.5
φD H7		48	56	64	80	106	132
φE H7		11	15	20	24	32	40
φF		9	9	18	22	29	37
φG H7		30	34	40	52	70	80
φH		49	59	69	84	110	132
φI h7		70	80	90	110	142	170
J		4.9	5.4	4.8	5.5	6	7
K		2.5	2.5	2.5	3	3	3
L		12.9	13.4	16.8	19.5	22	27
M		2.8 ^{+0.2}	2.8 ^{+0.2}	2.8 ^{+0.2}	3.4 ^{+0.2}	3.5 ^{+0.2}	3.6 ^{+0.2}
N		4 ^{-0.1}	5 ^{-0.1}	5.2 ^{-0.1}	6.3 ^{-0.1}	8.6 ^{-0.1}	10.3 ^{-0.1}
φO (PCD)		17	21	26	30	40	50
P		4	4	4	4	4	4
Q		M3	M3	M3	M3	M4	M5
φR (PCD)		64	74	84	102	132	158
S		6	8	8	10	10	10
T		3.4	3.4	3.4	4.5	5.5	6.6
φU (PCD)		42	50	60	73	96	116
V		8	10	8	8	8	12
W		M3×5	M3×6	M4×8	M5×8	M6×10	M6×10
X		34.5×0.80	38.0×1.50	S48	S60	S80	S100
Y		49.0×1.50	59.4×1.20	S70	S85	S115	S140
φZ		38	45	53	66	86	106
Mass (kg)		0.50	0.66	0.94	1.7	3.3	5.7

●由于零部件的制造方法（铸造、机械加工）不同，公差也存在差异。关于没有注明公差的尺寸，如需了解公差范围，请咨询本公司或授权代理商。

Positional accuracy

See "Engineering data" for a description of terms.

Table 214-1

Size	14	17	20	25	32	40	50
Positional Accuracy	×10 ⁻⁴ rad	4.4	4.4	2.9	2.9	2.9	2.9
	arc min	1.5	1.5	1.0	1.0	1.0	1.0

Hysteresis loss

See "Engineering data" for a description of terms.

Table 214-2

Ratio	Unit	Size	14	17	20	25	32	40	50
50	×10 ⁻⁴ rad		7.3	4.4	4.4	4.4	4.4	4.4	4.4
	arc min		2.5	1.5	1.5	1.5	1.5	1.5	1.5
100 or more	×10 ⁻⁴ rad		5.8	2.9	2.9	2.9	2.9	2.9	2.9
	arc min		2.0	1.0	1.0	1.0	1.0	1.0	1.0

Torsional stiffness

See "Engineering data" for a description of terms.

Table 214-3

Item	Unit	Size	14	17	20	25	32	40	50	
T ₁	Nm		2.0	3.9	7.0	14	29	54	108	
	kgfm		0.2	0.4	0.7	1.4	3.0	5.5	11	
T ₂	Nm		6.9	12	25	48	108	196	382	
	kgfm		0.7	1.2	2.5	4.9	11	20	39	
Reduction ratio 50	K ₁	×10 ⁴ Nm/rad	0.29	0.67	1.1	2.0	4.7	8.8	17	
		kgfm/arc min	0.085	0.2	0.32	0.6	1.4	2.6	5.0	
	K ₂	×10 ⁴ Nm/rad	0.37	0.88	1.3	2.7	6.1	11	21	
		kgfm/arc min	0.11	0.26	0.4	0.8	1.8	3.4	6.3	
	K ₃	×10 ⁴ Nm/rad	0.47	1.2	2.0	3.7	8.4	15	30	
		kgfm/arc min	0.14	0.34	0.6	1.1	2.5	4.5	9.0	
	θ ₁	×10 ⁻⁴ rad	6.9	5.8	6.4	7.0	6.2	6.1	6.4	
		arc min	2.4	2.0	2.2	2.4	2.1	2.1	2.2	
	θ ₂	×10 ⁻⁴ rad	19	14	19	18	18	18	18	
		arc min	6.4	4.6	6.6	6.1	6.1	5.9	6.2	
	Reduction ratio 100 or more	K ₁	×10 ⁴ Nm/rad	0.4	0.84	1.3	2.7	6.1	11	21
			kgfm/arc min	0.12	0.25	0.4	0.8	1.8	3.2	6.3
K ₂		×10 ⁴ Nm/rad	0.44	0.94	1.7	3.7	7.8	14	29	
		kgfm/arc min	0.13	0.28	0.5	1.1	2.3	4.2	8.5	
K ₃		×10 ⁴ Nm/rad	0.61	1.3	2.5	4.7	11	20	37	
		kgfm/arc min	0.18	0.39	0.75	1.4	3.3	5.8	11	
θ ₁		×10 ⁻⁴ rad	5.0	4.6	5.4	5.2	4.8	4.9	5.1	
		arc min	1.7	1.6	1.8	1.8	1.7	1.7	1.7	
θ ₂		×10 ⁻⁴ rad	16	13	15	13	14	14	13	
		arc min	5.4	4.3	5.0	4.5	4.8	4.8	4.6	

* The values in this table are reference values. The minimum value is approximately 80% of the displayed value.

Starting torque

See "Engineering data" for a description of terms. The values in the table below vary depending on the use conditions, use them as reference values.

CSD-2UH

Table 214-4 Unit: Ncm

Ratio	Size	14	17	20	25	32	40	50
50		4.4	6.7	8.9	16	32	55	102
100		2.8	3.8	5.1	9.1	20	32	60
160		—	—	3.9	7.2	15	26	47

CSD-2UF

Table 214-5 Unit: Ncm

Ratio	Size	14	17	20	25	32	40
50		5.3	7.5	9.7	17	34	58
100		3.2	4.2	5.5	9.6	21	33
160		—	—	4.1	7.4	16	27

Backdriving torque

See "Engineering data" for a description of terms. The values in the table below vary depending on the use conditions, use them as reference values.

CSD-2UH

Table 215-1 Unit: Nm

Ratio	Size	14	17	20	25	32	40	50
50		2.9	4.3	5.2	9.5	19	33	61
100		3.5	4.6	6.0	11	23	38	71
160		—	—	7.4	13	30	48	89

CSD-2UF

Table 215-2 Unit: Nm

Ratio	Size	14	17	20	25	32	40
50		3.3	4.7	5.6	10	20	34
100		3.9	5.0	6.4	11	24	39
160		—	—	7.8	14	31	49

Ratcheting torque

See "Engineering data" for a description of terms.

Table 215-3 Unit: Nm

Ratio	Size	14	17	20	25	32	40	50
50		88	150	220	450	980	1800	3700
100		84	160	260	500	1000	2100	4100
160		—	—	220	450	980	1800	3600

Buckling torque

See "Engineering data" for a description of terms.

Table 215-4 Unit: Nm

Size	14	17	20	25	32	40	50
Total reduction ratio	190	330	560	1000	2200	4300	8000

Checking output bearing

A precision cross roller bearing is built in the gear unit to directly support the external load (output flange). Check the maximum moment load, life of the bearing and static safety coefficient to fully bring out the performance of the unit type. See Page 030 to 034 of "Engineering data" for each calculation formula.

Checking procedure

(1) Checking the maximum moment load (Mmax)



(2) Checking the life

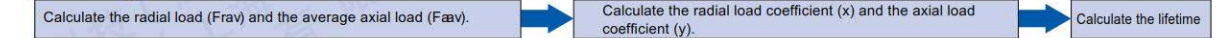

(3) Checking the static safety coefficient

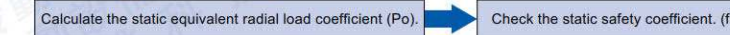

Output bearing specifications

The specifications of the cross roller bearing are shown in Table 220-1 and -2.

CSD-2UH

Table 220-1

Size	Pitch circle dia. of a roller dp	Offset R	Basic rated load				Allowable moment load Mc		Moment stiffness Km		Allowable axial load Fa		Allowable radial load Fr	
			Basic dynamic rated load C		Basic static rated load Co		Nm	kgfm	×10 ⁴ Nm / rad	kgfm / arc-min	×10 ² N		×10 ² N	
			×10 ² N	kgf	×10 ² N	kgf					×10 ² N	×10 ² N		
14	0.035	0.0095	47	480	60.7	620	41	4.2	4.38	1.3	10.1	6.74	6.74	
17	0.0425	0.0099	52.9	540	75.5	770	64	6.5	7.75	2.3	11.3	7.58	7.58	
20	0.050	0.0102	57.8	590	90	920	91	9.3	12.8	3.8	12.4	8.28	8.28	
25	0.062	0.0130	96.0	980	151	1540	156	16	24.2	7.2	20.5	13.8	13.8	
32	0.080	0.0144	150	1530	250	2550	313	32	53.9	16	32.1	2.15	2.15	
40	0.096	0.0151	213	2170	365	3720	450	46	91	27	45.6	3.05	3.05	
50	0.119	0.0192	348	3550	602	6140	759	77	171	51	74.4	4.99	4.99	

CSD-2UF

Table 220-2

Size	Pitch circle dia. of a roller dp	Offset R	Basic rated load				Allowable moment load Mc		Moment stiffness Km		Allowable axial load Fa		Allowable radial load Fr	
			Basic dynamic rated load C		Basic static rated load Co		Nm	kgfm	×10 ⁴ Nm / rad	kgfm / arc-min	×10 ² N		×10 ² N	
			×10 ² N	kgf	×10 ² N	kgf					×10 ² N	×10 ² N		
14	0.050	0.0118	57.8	590	90	920	91	9.3	12.8	3.8	12.4	8.28	8.28	
17	0.060	0.0123	104	1060	163	1670	124	12.6	15.4	4.6	22.2	14.9	14.9	
20	0.070	0.0128	146	1490	220	2250	187	19.1	25.2	7.5	31.2	20.9	20.9	
25	0.085	0.0134	218	2230	358	3660	258	26.3	39.2	11.6	46.6	31.2	31.2	
32	0.111	0.0168	382	3900	654	6680	580	59.1	100	29.6	81.7	54.7	54.7	
40	0.133	0.0215	433	4410	816	8330	849	86.6	179	53.2	92.6	62.0	62.0	

(Note)

- * The basic dynamic rated load means a certain static radial load so that the basic dynamic rated life of the roller bearing is one million rotations.
- * The basic static rated load means a static load that gives a certain level of contact stress (4 kN/mm²) in the center of the contact area between the rolling element receiving the maximum load and the orbit.
- * The value of the moment stiffness is the average value.
- * Allowable moment load is the maximum moment load that may be applied to the output shaft. Please adhere to these values for optimum performance. The value of the moment stiffness is the reference value. The lower-limit value is approximate 80% of the displayed value.
- * Allowable axial or radial load is the value that satisfies the reducer life when either a genuine radial load or an axial load is applied to the main shaft. (When radial load is Lr+R=0mm, and axial load is La=0mm)

Recommended tolerances for assembly

Recommended tolerances for assembly

Input: Wave generator
Output: Circular spline
Fixed: Flexspline

CSD-2UH

Table 221-1 Unit: mm

Symbol	Size	14	17	20	25	32	40	50
a		0.010	0.010	0.010	0.015	0.015	0.015	0.018
b		0.010	0.012	0.012	0.013	0.013	0.015	0.015
c		0.007	0.007	0.007	0.007	0.007	0.007	0.007
d		0.010	0.010	0.010	0.010	0.010	0.015	0.015
e		0.025	0.025	0.025	0.035	0.037	0.037	0.040

CSD-2UF

Table 221-2 Unit: mm

Symbol	Size	14	17	20	25	32	40
a		0.010	0.010	0.010	0.015	0.015	0.015
b		0.010	0.010	0.010	0.010	0.013	0.013
c		0.010	0.010	0.010	0.010	0.013	0.013
d		0.010	0.010	0.010	0.010	0.013	0.013
e		0.031	0.031	0.031	0.041	0.047	0.047

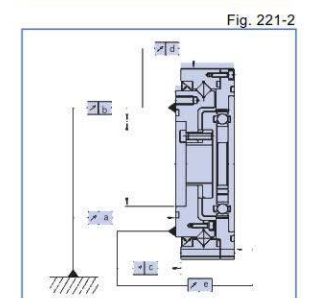
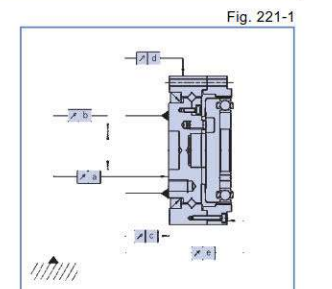

Design Guide

Installation and transmission torque



Installation on output flange side and resulting transmission torque

■ CSD-2UH

Table 223-1

Item	Size	14	17	20	25	32	40	50
Number of bolts		10	8	8	8	10	10	10
Bolt size		M3	M5	M6	M8	M8	M10	M12
Pitch circle	mm	25	27	34	42	57	72	88
Bolt tightening torque	Nm	2.4	10.8	18.4	44	44	74	128
Torque transmission capacity (bolt only)	Nm	50	122	217	486	824	1665	2933

■ CSD-2UF

Table 223-2

Item	Size	14	17	20	25	32	40
Number of bolts		8	10	8	8	8	12
Bolt size		M3	M3	M4	M5	M6	M6
Pitch circle	mm	42	50	60	73	96	116
Bolt tightening torque	Nm	2.4	2.4	5.4	10.8	18.4	18.4
Torque transmission capacity (bolt only)	Nm	70	104	167	329	765	1109

Bolt connection to housing and resulting transmission torque

■ CSD-2UH

Table 223-3

Item	Size	14	17	20	25	32	40	50
Number of bolts		6	10	12	18	18	18	22
Bolt size		M3	M3	M3	M3	M4	M5	M6
Pitch circle	mm	49	56	64	79	104	117.5	147
Bolt tightening torque	Nm	2.4	2.4	2.4	2.4	5.4	10.8	18.4
Torque transmission capacity (bolt only)	Nm	43	82	112	207	461	833	1804

■ CSD-2UF

Table 223-4

Item	Size	14	17	20	25	32	40
Number of bolts		6	8	8	10	10	10
Bolt size		M3	M3	M3	M4	M5	M6
Pitch circle	mm	64	74	84	102	132	158
Bolt tightening torque	Nm	2.4	2.4	2.4	5.4	10.8	18.4
Torque transmission capacity (bolt only)	Nm	80	123	140	359	743	1259

(Table 223-1 to 223-4/Notes)

- The material of the thread must withstand the clamp torque.
- Recommended bolt: JIS B 1176 socket head cap screw / Strength range : JIS B 1051 over 12.9
- Torque coefficient: K=0.2
- Clamp coefficient: A=1.4
- Tightening friction coefficient $\mu=0.15$

Recommended tolerances for assembly

For peak performance of the gear, it is essential that the following tolerances be observed when assembly is complete. Pay careful attention to the following points and maintain the recommended assembly tolerances to avoid grease leakage.

- Warp and deformation on the mounting surface
- Blocking of foreign matter
- Problems caused by burrs, raised surfaces and location around the tap area of the mounting holes
- Insufficient chamfering on the housing mount
- Insufficient radii on the housing mount

Recommended Tolerances for Assembly

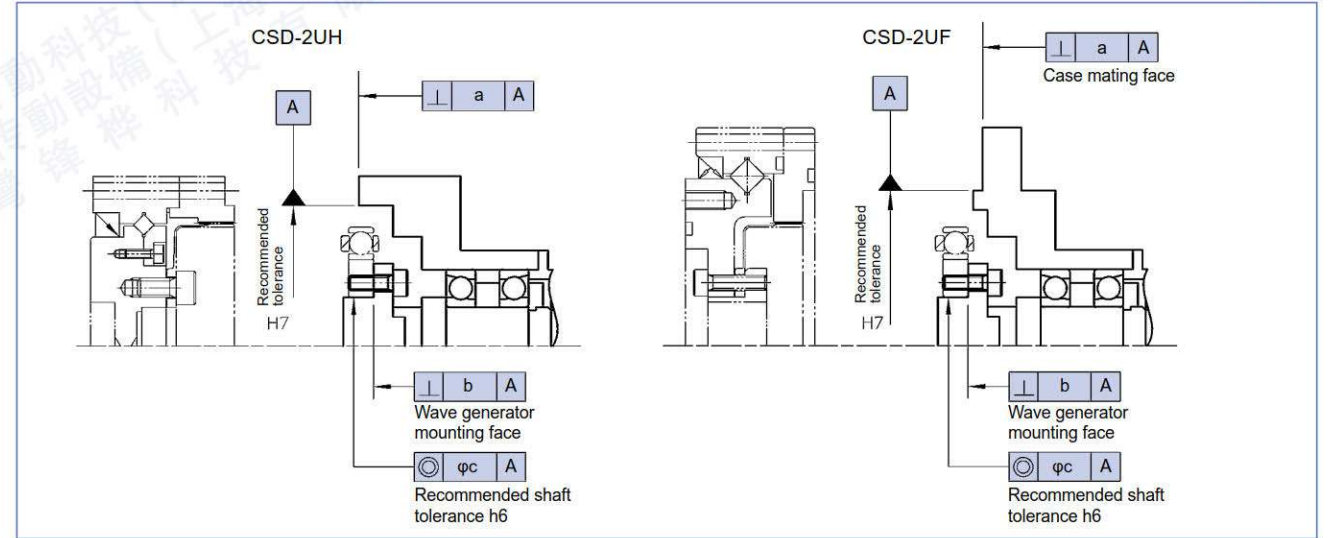

Tolerances for Assembly CSD-2UH

Table 222-1 Unit: mm

Symbol	Size	14	17	20	25	32	40	50
a		0.011	0.015	0.017	0.024	0.026	0.026	0.028
b		0.008	0.010	0.012	0.012	0.012	0.012	0.015
φc		0.016	0.018	0.019	0.022	0.022	0.024	0.030

Tolerances for Assembly CSD-2UF

Table 222-2 Unit: mm

Symbol	Size	14	17	20	25	32	40
a		0.011	0.015	0.017	0.024	0.026	0.026
b		0.008	0.010	0.012	0.012	0.012	0.012
φc		0.016	0.018	0.019	0.022	0.022	0.024

Lubrication

Grease lubrication is standard for the CSD-2UH and CSD-2UF. There is no need to add or apply grease upon installation since the products are shipped with the grease applied. See table below for recommended housing dimensions. These dimensions must be maintained to prevent damage to the gear and to maintain a proper grease cavity.

Recommended housing dimensions

Table 224-1 Unit: mm

Symbol	Size	14	17	20	25	32	40	50
a*		1	1	1.5	1.5	2	2.5	3.5
a**		3	3	4.5	4.5	6	7.5	10.5
φb ^{+0.5} ₀		16	26	30	37	37	45	45

* For the wave generator facing downward

** For the wave generator facing upward

Sealing

The following sealing mechanism is required to prevent grease leakage and maintain the high durability of the gear.

- Rotating Parts** Oil seal (with a spring). Surface should be smooth (no scratches)
- Mating flange** O-ring and seal adhesive. Take care regarding distortion on the plane and how the O-ring is engaged.
- Screw hole area**..... Screws should have a thread lock (Loctite 242 is recommended) or seal adhesive.

(Note) If you use Harmonic Grease® 4BNo.2 lubrication, strict sealing is required.

Fig. 224-1

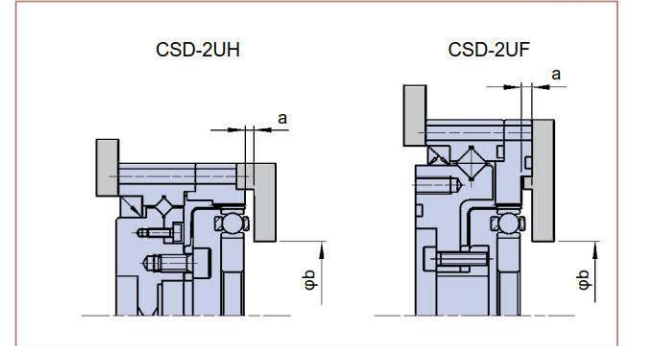
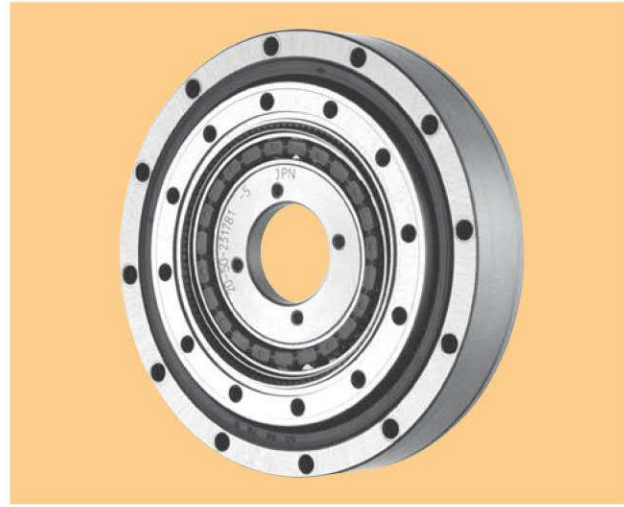

Table 224-3

Area requiring sealing		Recommended sealing method
Output side	Pass-through hole in the center of the output flange and the output flange mating face	Use O-ring (supplied with the product)
	Mounting screw area	Screw lock agent with sealing effect (Loctite 242 is recommended)
Input side	Flange mating face	Use O-ring (supplied with the product)
	Motor output shaft	Please select a motor which has an oil seal on the output shaft.

Features



SHD series

Axially compact, these gear units feature a large hollow input shaft and a robust cross roller bearing so loads can be mounted directly to the unit without the need for additional support bearings

Features of SHD series

- Zero Backlash
- Ultra-flat design - 15% thinner than the SHF Series
- Large Hollow Input Shaft
- Accuracy <1 arc-min (most sizes)
- Rigid cross roller output bearing
- Lightweight - 30% lower weight than Standard SHF Series

Structure of SHD gear unit

Fig. 268-1

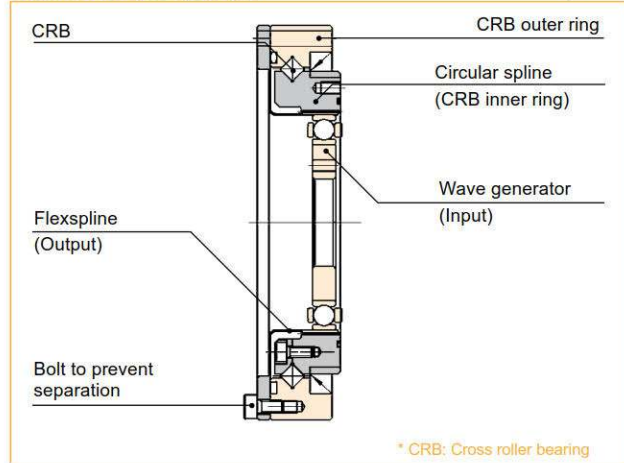

Shaft thickness

Fig. 268-2

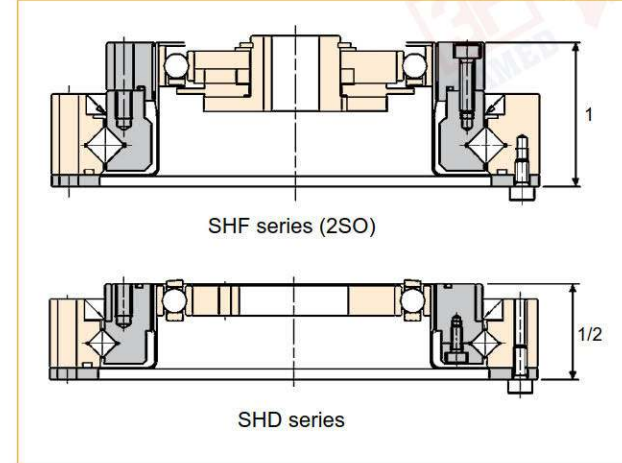

Application example, SHD series

Fig. 269-1

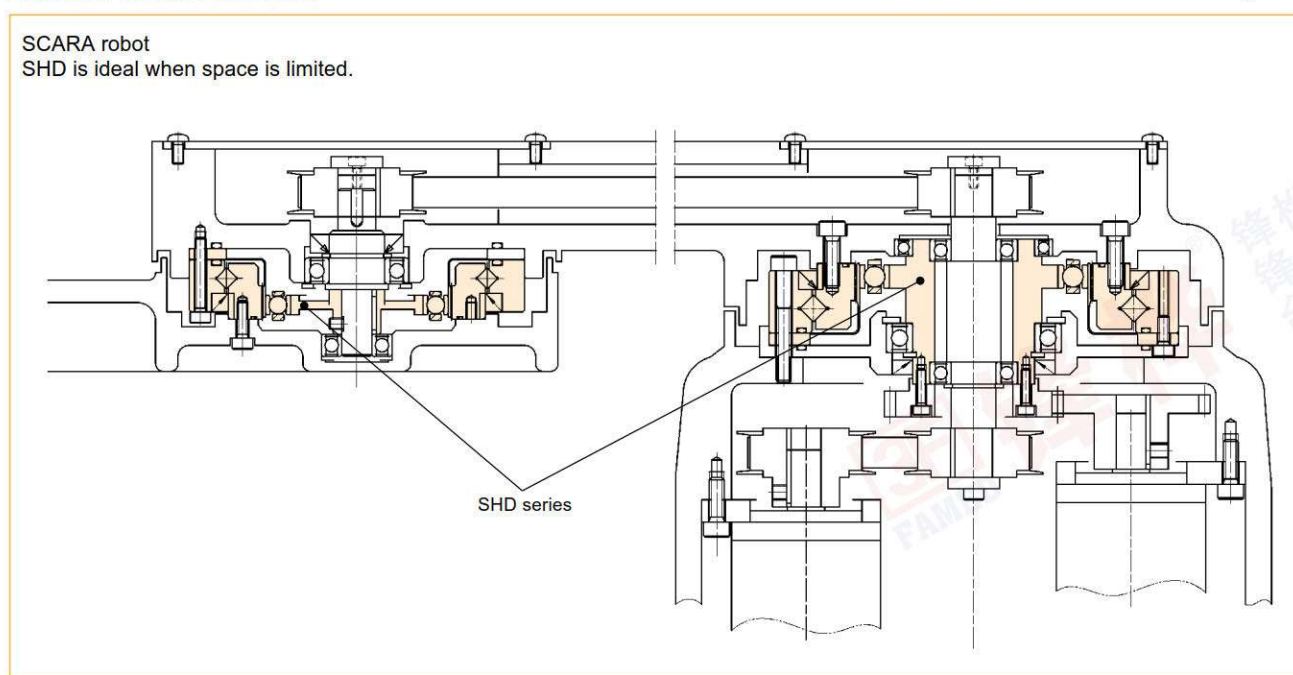

Ordering Code

SHD - 20 - 100 - 2SH - SP

Table 269-1

Series	Size	Ratio*1				Model	Special specification
SHD	14	50	100	—		2SH = Simplicity Unit 2UH = Gear Unit	LW = Lightweight SP= Special specification code Blank=Standard product
	17	50	100	—			
	20	50	100	160	160		
	25	50	100	160	160		
	32	50	100	160	160		
	40	50	100	160	160		

*1 The reduction ratio value is based on the following configuration:
Input: wave generator, fixed: circular spline, output: flexspline

Technical Data

Rating table

Table 270-1

Size	Ratio	Rated Torque at 2000rpm		Limit for Repeated Peak Torque		Limit for Average Torque		Limit for Momentary Peak Torque		Maximum Input Speed (rpm)	Limit for Average Input Speed (rpm)	Moment of Inertia	
		Nm	kgfm	Nm	kgfm	Nm	kgfm	Nm	kgfm			Grease lubricant	Grease lubricant
14	50	3.7	0.38	12	1.2	4.8	0.49	23	2.3	8500	3500	0.021	0.021
	100	5.4	0.55	19	1.9	7.7	0.79	35	3.6				
17	50	11	1.1	23	2.3	18	1.9	48	4.9	7300	3500	0.054	0.055
	100	16	1.6	37	3.8	27	2.8	71	7.2				
20	50	17	1.7	39	4.0	24	2.4	69	7.0	6500	3500	0.090	0.092
	100	28	2.9	57	5.8	34	3.5	95	10				
	160	28	2.9	64	6.5	34	3.5	95	10				
25	50	27	2.8	69	7.0	38	3.9	127	13	5600	3500	0.282	0.288
	100	47	4.8	110	11	75	7.6	184	19				
	160	47	4.8	123	13	75	7.6	204	21				
32	50	53	5.4	151	15	75	7.6	268	27	4800	3500	1.09	1.11
	100	96	10	233	24	151	15	420	43				
40	160	96	10	261	27	151	15	445	45	4000	3000	2.85	2.91
	50	96	10	281	29	137	14	480	49				
	100	185	19	398	41	260	27	700	71				
	160	206	21	453	46	316	32	765	78				

(Note) 1. Moment of Inertia: $I = \frac{1}{4} GD^2$

2. See Rating Table Definitions on Page 12 for details of the terms.

Outline Dimensions SHD-2SH

You can download the CAD files from our website: harmonicdrive.net

Fig. 270-1

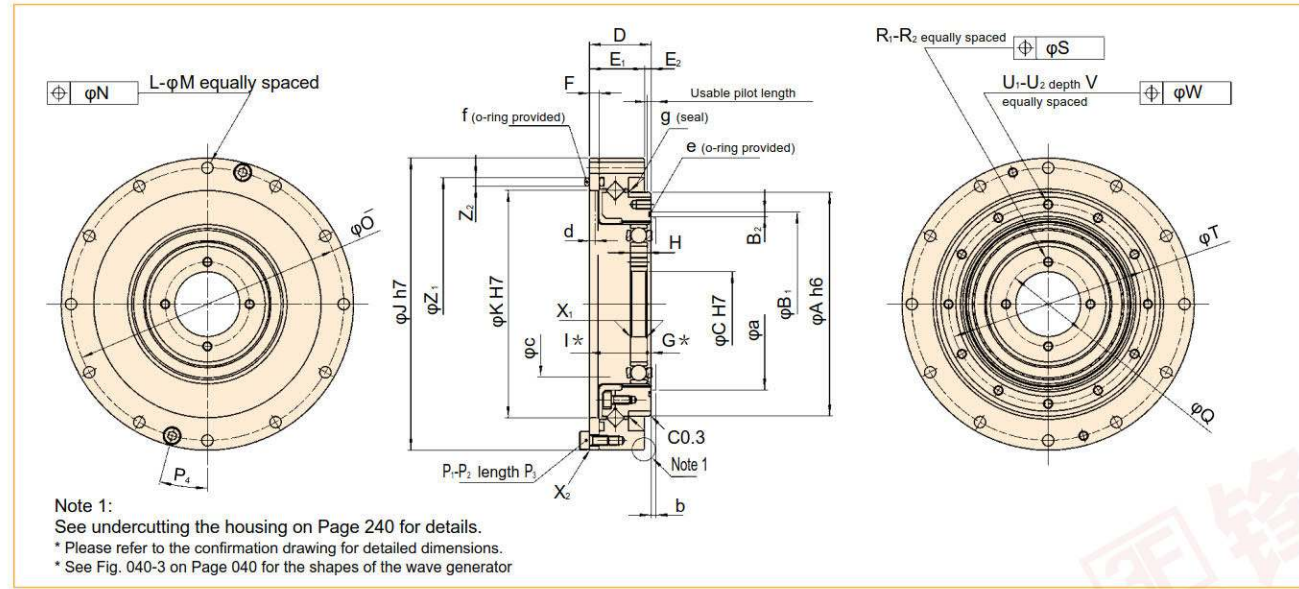

Note 1:
See undercutting the housing on Page 240 for details.
* Please refer to the confirmation drawing for detailed dimensions.
* See Fig. 040-3 on Page 040 for the shapes of the wave generator

Dimensions SHD-2SH

Table 271-1 Unit: mm

Symbol	Size	14	17	20	25	32	40
φA h6		49 ⁰ _{-0.016}	59 ⁰ _{-0.019}	69 ⁰ _{-0.019}	84 ⁰ _{-0.022}	110 ⁰ _{-0.022}	132 ⁰ _{-0.025}
φB ₁		39.1 ⁰ _{-0.011}	48 ⁰ _{-0.011}	56.8 ⁰ _{-0.011}	70.5 ⁰ _{-0.011}	92 ⁰ _{-0.011}	112.4 ⁰ _{-0.011}
B ₂		0.8 ⁰ _{-0.015}	1.1 ⁰ _{-0.025}	1.4 ⁰ _{-0.025}	1.7 ⁰ _{-0.025}	2 ⁰ _{-0.025}	2.2 ⁰ _{-0.025}
φC H7		11 ⁰ _{-0.018}	15 ⁰ _{-0.018}	20 ⁰ _{-0.021}	24 ⁰ _{-0.021}	32 ⁰ _{-0.025}	40 ⁰ _{-0.025}
D		17.5 ^{±0.1}	18.5 ^{±0.1}	19 ^{±0.1}	22 ^{±0.1}	27.9 ^{±0.1}	33 ^{±0.1}
E ₁		15.5	16.5	17	20	23.6	28
E ₂		2	2	2	2	4.3	5
F		2.4	3	3	3.3	3.6	4
G*		1.8	1.6	1.2	0.4	0.6	0.8
H		4 ^{-0.1}	5 ^{-0.1}	5.2 ^{-0.1}	6.35 ^{-0.1}	8.6 ^{-0.1}	10.3 ^{-0.1}
I*		15.7 ⁰ _{-0.2}	16.9 ⁰ _{-0.2}	17.8 ⁰ _{-0.2}	21.6 ⁰ _{-0.2}	27.3 ⁰ _{-0.2}	32.2 ⁰ _{-0.2}
φJ h7		70 ⁰ _{-0.030}	80 ⁰ _{-0.030}	90 ⁰ _{-0.035}	110 ⁰ _{-0.035}	142 ⁰ _{-0.040}	170 ⁰ _{-0.040}
φK H7		50 ⁰ _{-0.025}	61 ⁰ _{-0.030}	71 ⁰ _{-0.030}	88 ⁰ _{-0.035}	114 ⁰ _{-0.035}	140 ⁰ _{-0.040}
L		8	12	12	12	12	12
φM		3.5	3.5	3.5	4.5	5.5	6.6
φN		0.25	0.25	0.25	0.25	0.25	0.3
φO		64	74	84	102	132	158
P ₁		2	2	2	4	4	4
P ₂		M3	M3	M3	M3	M4	M4
P ₃		6	6	6	8	10	10
P ₄		22.5°	15°	15°	15°	15°	15°
φQ		17	21	26	30	40	50
R ₁		4	4	4	4	4	4
R ₂		M3	M3	M3	M3	M4	M5
φS		0.25	0.25	0.25	0.25	0.25	0.25
φT		43	52	61.4	76	99	120
U ₁		8	12	12	12	12	12
U ₂		M3	M3	M3	M4	M5	M6
V		4.5	4.5	4.5	6	8	9
φW		0.25	0.25	0.25	0.25	0.25	0.3
X ₁		C0.4	C0.4	C0.5	C0.5	C0.5	C0.5
X ₂		C0.4	C0.4	C0.5	C0.5	C0.5	C0.5
Z ₁		57 ⁰ _{-0.1}	68.1 ⁰ _{-0.1}	78 ⁰ _{-0.1}	94.8 ⁰ _{-0.1}	123 ⁰ _{-0.1}	148 ⁰ _{-0.1}
Z ₂		2 ⁰ _{-0.25}	2.7 ⁰ _{-0.25}	2.4 ⁰ _{-0.25}	2.7 ⁰ _{-0.25}	2.7 ⁰ _{-0.25}	2.7 ⁰ _{-0.25}
φa		36.5	45	53	66	86	106
b		1	1	1.5	1.5	2	2.5
φc		31	38	45	56	73	90
d		1.4	1.8	1.7	1.8	1.8	1.8
e		d37.1d0.6	d45.4d0.8	d53.28d0.99	d66.5d1.3	d87.5d1.5	d107.5d1.6
f		d54.38d1.19	d64.0d1.5	d72.0d2.0	d88.62d1.78	d117.0d2.0	d142d2.0
g		D49585	D59685	D69785	D84945	D1101226	D1321467
h		1.5	1.5	1.5	1.5	3.3	4
Mass (kg)		0.33	0.42	0.52	0.91	1.87	3.09

● The following dimensions can be modified to accommodate:
Wave Generator: C
Flexspline: O and P
Circular Spline: X₁ and X₂

● The G and I sizes indicated by an asterisk are the mounting positions in the shaft direction and allowance of the three parts (wave generator, flexspline, circular spline). Strictly observe these sizes as they affect the performance and strength.
● As the flexspline is subject to elastic deformation, the inner wall should be φa, b, c or more and it should not exceed φd to prevent possible contact with the housing.

Positional Accuracy

See "Engineering data" for a description of terms.

Table 273-1 Unit: X10⁻⁴ rad (arc min)

Size	14	17	20	25	32	40	
Positional Accuracy	×10 ⁻⁴ rad	4.4	4.4	2.9	2.9	2.9	2.9
	arc min	1.5	1.5	1.0	1.0	1.0	1.0

Hysteresis loss

See "Engineering data" for a description of terms.

Table 273-2

Ratio	Size	14	17	20	25	32	40
50	×10 ⁻⁴ rad	7.3	5.8	5.8	5.8	5.8	5.8
	arc min	2.5	2.0	2.0	2.0	2.0	2.0
100 or more	×10 ⁻⁴ rad	5.8	2.9	2.9	2.9	2.9	2.9
	arc min	2.0	1.0	1.0	1.0	1.0	1.0

Torsional Stiffness

See "Engineering data" for a description of terms.

Table 273-3

Symbol	Size	14	17	20	25	32	40	
T ₁	Nm	2.0	3.9	7.0	14	29	54	
	kgfm	0.2	0.4	0.7	1.4	3.0	5.5	
T ₂	Nm	6.9	12	25	48	108	196	
	kgfm	0.7	1.2	2.5	4.9	11	20	
Ratio 50	K _i	×10 ⁴ Nm/rad	0.29	0.67	1.1	2.0	4.7	8.8
		kgfm/arc min	0.085	0.2	0.32	0.6	1.4	2.6
	K _e	×10 ⁴ Nm/rad	0.37	0.88	1.3	2.7	6.1	11
		kgfm/arc min	0.11	0.26	0.4	0.8	1.8	3.4
	K _s	×10 ⁴ Nm/rad	0.47	1.2	2.0	3.7	8.4	15
		kgfm/arc min	0.14	0.34	0.6	1.1	2.5	4.5
θ _i	×10 ⁻⁴ rad	6.9	5.8	6.4	7.0	6.2	6.1	
	arc min	2.4	2.0	2.2	2.3	2.1	2.1	
θ _e	×10 ⁻⁴ rad	19	14	19	18	18	18	
	arc min	6.4	4.6	6.3	6.1	6.1	5.9	
Ratio 100 or more	K _i	×10 ⁴ Nm/rad	0.4	0.84	1.3	2.7	6.1	11
		kgfm/arc min	0.12	0.25	0.4	0.8	1.8	3.2
	K _e	×10 ⁴ Nm/rad	0.44	0.94	1.7	3.7	7.8	14
		kgfm/arc min	0.13	0.28	0.5	1.1	2.3	4.2
	K _s	×10 ⁴ Nm/rad	0.61	1.3	2.5	4.7	11	20
		kgfm/arc min	0.18	0.39	0.75	1.4	3.3	5.8
θ _i	×10 ⁻⁴ rad	5.0	4.6	5.4	5.2	4.8	4.9	
	arc min	1.7	1.6	1.8	1.8	1.7	1.7	
θ _e	×10 ⁻⁴ rad	16	13	15	13	14	14	
	arc min	5.4	4.3	5.0	4.5	4.8	4.8	

* The values in this table are reference values. The minimum value is approximately 80% of the displayed value.

Simplicity unit (2SH) Starting torque

See "Engineering data" for a description of terms. The values are reference values.

Table 274-1 Unit: Ncm

Ratio	Size	14	17	20	25	32	40
50		6.2	19	25	39	60	95
100		4.8	17	22	34	50	78
160		—	—	22	33	47	74

Simplicity unit (2SH) Backdriving torque

See "Engineering data" for a description of terms. The values are reference values.

Table 274-3 Unit: Ncm

Ratio	Size	14	17	20	25	32	40
50		3.7	11	15	24	36	57
100		5.8	21	27	41	60	94
160		—	—	42	64	91	143

Ratcheting torque

See "Engineering data" for a description of terms.

Table 274-5 Unit: Nm

Ratio	Size	14	17	20	25	32	40
50		88	150	220	450	980	1800
100		84	160	260	500	1000	2100
160		—	—	220	450	980	1800

Buckling torque

See "Engineering data" for a description of terms.

Table 274-6 Unit: Nm

Size	14	17	20	25	32	40
Total reduction ratio	130	260	470	850	1800	3600

Checking output bearing

A precision cross roller bearing is built in the unit type to directly support the external load (output flange).

Check the maximum moment load, life of the cross roller bearing and static safety coefficient to fully bring out the performance of the unit type.

See page 030 to 034 of "Engineering data" for each calculation formula.

Checking procedure

(1) Checking the maximum moment load (M_{max})



(2) Checking the life

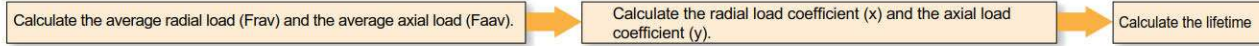

(3) Checking the static safety coefficient

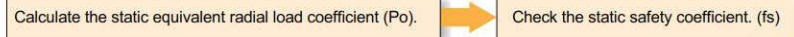

Output bearing specifications

The specifications of the cross roller are shown in Table 280-1.

Specifications

Table 280-1

Size	Pitch circle dia. of a roller	Offset R	Basic rated load				Allowable moment load M_c		Moment stiffness K_m	
	dp		Basic dynamic rated load C		Basic static rated load C_o		Nm	kgfm	$\times 10^4$ Nm/rad	kgf m/arc min
			$\times 10^4$ N	kgf	$\times 10^4$ N	kgf				
14	0.0503	0.0111	29	296	43	438	37	3.8	7.08	2.1
17	0.061	0.0115	52	530	81	826	62	6.3	12.7	3.8
20	0.070	0.011	73	744	110	1122	93	9.5	21	6.2
25	0.086	0.0121	109	1111	179	1825	129	13.2	31	9.2
32	0.112	0.0173	191	1948	327	3334	290	29.6	82.1	24.4
40	0.133	0.0195	216	2203	408	4160	424	43.2	145	43.0

(Note) * The basic dynamic rated load means a certain static radial load so that the basic dynamic rated life of the roller bearing is one million rotations.
* The basic static rated load means a static load that gives a certain level of contact stress (4 kN/mm^2) in the center of the contact area between the rolling element receiving the maximum load and the orbit.
* The value of the moment stiffness is the average value.

* As the life of the cross roller bearing of the unit of the reduction ratio corresponding to the table below (Table 280-2) is shorter than that $(n^{0.8})$ of the gear during operation under the allowable moment load, consideration should be made in designing the load condition and the lifetime.

(Note) The life of the gear indicates the life ($L_{10}=7000$ hours) of the wave generator bearing when it operates at 2000rpm input rotational speed and the rated torque (see "Life of the wave generator" on Page 012).

Design Guide

Installation accuracy

For peak performance of the gear, it is essential that the following tolerances be observed when assembly is complete.

Pay careful attention to the following points and maintain the recommended assembly tolerances to avoid grease leakage.

- Warp and deformation on the mounting surface
- Blocking of foreign matter
- Problems caused by burrs, raised surfaces and location around the tap area of the mounting holes
- Insufficient chamfering on the housing mount
- Insufficient radii on the housing mount

Recommended tolerances for assembly

Fig. 281-1

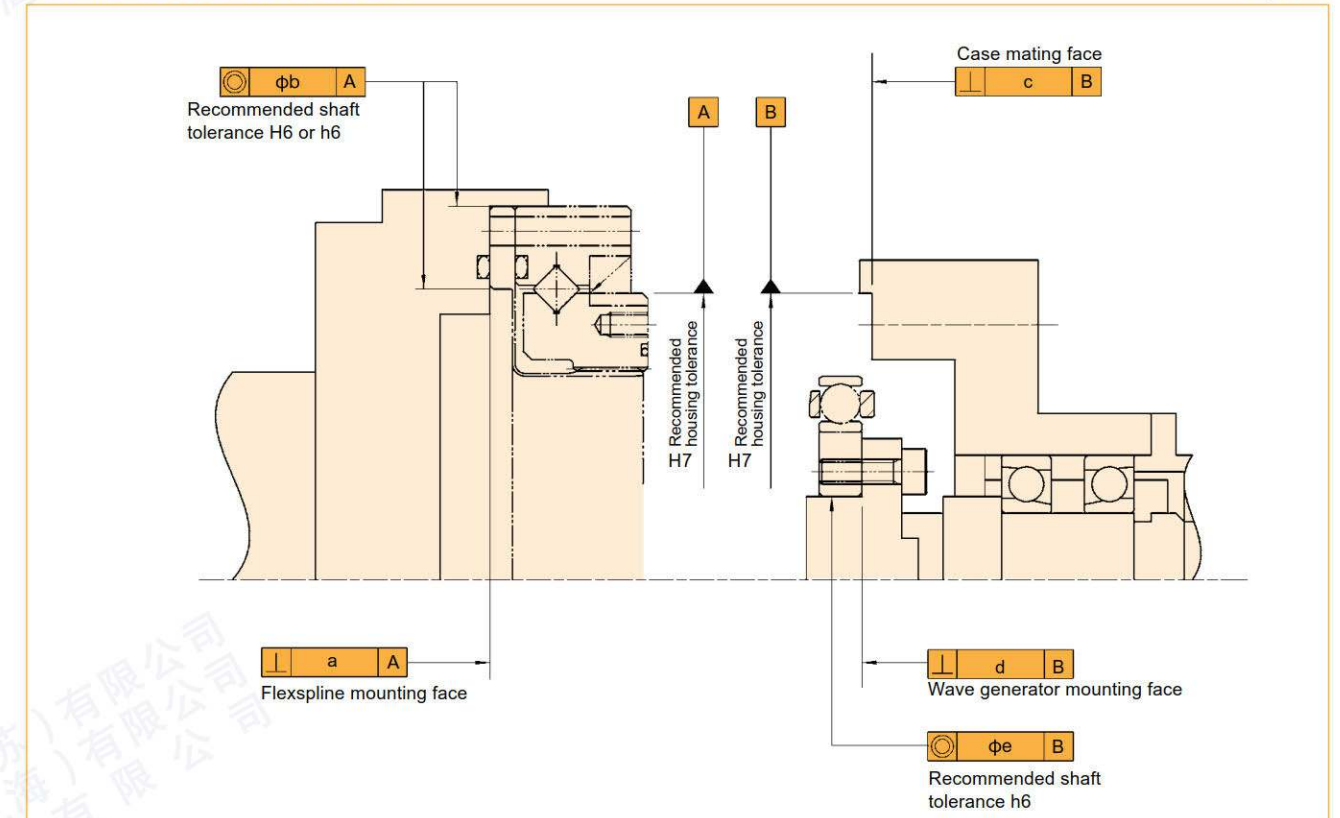

Recommended tolerances for assembly

Table 281-1

Unit mm

Symbol	Size	14	17	20	25	32	40
a		0.016	0.021	0.027	0.035	0.042	0.048
φb		0.015	0.018	0.019	0.022	0.022	0.024
c		0.011	0.012	0.013	0.014	0.016	0.016
d		0.008	0.010	0.012	0.012	0.012	0.012
φe		0.016	0.018	0.019	0.022	0.022	0.024

Installation and transmission torque

Installation and transmission torque on (A) side

Table 282-2

Item	Size	14	17	20	25	32	40
Number of bolts		8	12	12	12	12	12
Bolt size		M3	M3	M3	M4	M5	M6
Pitch Circle Diameter	mm	64	74	84	102	132	158
Clamp torque	Nm	2.0	2.0	2.0	4.5	9.0	15.3
Transmission torque	Nm	108	186	210	431	892	1509

- (Notes) 1. The material of the thread must withstand the clamp torque.
 2. Recommended bolt: JIS B 1176 socket head cap screw. Strength range : JIS B 1051 over 12.9.
 3. Torque coefficient: K=0.2
 4. Tightening coefficient: A=1.4
 5. Tightening friction coefficient $\mu=0.15$

Installation and transmission torque on (B) side

Table 282-3

Item	Size	14	17	20	25	32	40
Number of bolts		8	12	12	12	12	12
Bolt size		M3	M3	M3	M4	M5	M6
Pitch Circle Diameter	mm	43	52	61.4	76	99	120
Effective depth of screw part	mm	4.5	4.5	4.5	6	8	9
Clamp torque	Nm	2.0	2.0	2.0	4.5	9.0	15.3
Transmission torque	Nm	72	130	154	321	668	1148

- (Notes) 1. The material of the thread must withstand the clamp torque.
 2. Recommended bolt: JIS B 1176 socket head cap screw. Strength range : JIS B 1051 over 12.9.
 3. Torque coefficient: K=0.2
 4. Tightening coefficient: A=1.4
 5. Tightening friction coefficient $\mu=0.15$

* Since the flange material on the case side is AL (aluminum), be sure to tighten the bolt to the specified torque as described above.
 If the tightening torque exceeds the above value, the correct transmission torque may not be secured or the bolt may be loosened.
 Use washers instead of putting the aluminum directly on the bolt-bearing surface when tightening with the bolt from the A side.

Recessing of the mounting pilot

When the housing interferes with corner "A" shown below, an undercut in the housing is recommended.

Mounting pilot

Fig. 283-1

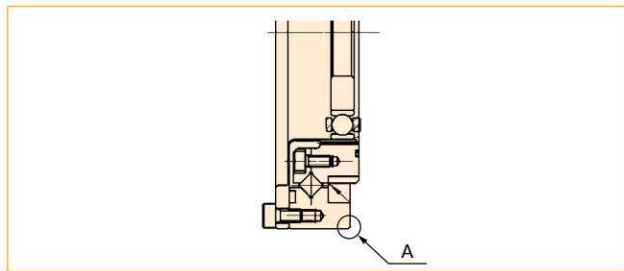

Recommended housing undercut

Fig. 283-2

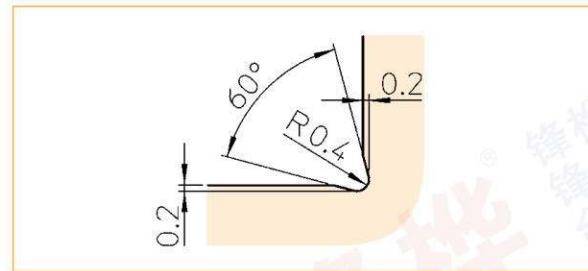

输出部和固定部

SHD系列的输出部会根据固定的位置而发生改变。此外，减速比和旋转方向也会发生变化，其关系如下所示。

表216-1

固定部	输出部	旋转方向和减速比
柔轮	刚轮	第009页的②
刚轮	柔轮	第009页的①

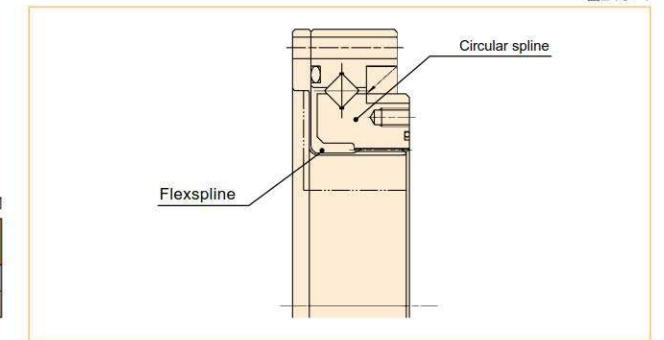

Lubrication

Standard lubrication for SHD series is grease lubrication. See "Engineering data" on Page 016 for details of the lubricant.

Recommended minimum housing clearance

These dimensions must be maintained to prevent damage to the gear and to maintain a proper grease cavity.

Recommended minimum housing clearance

Fig. 283-4

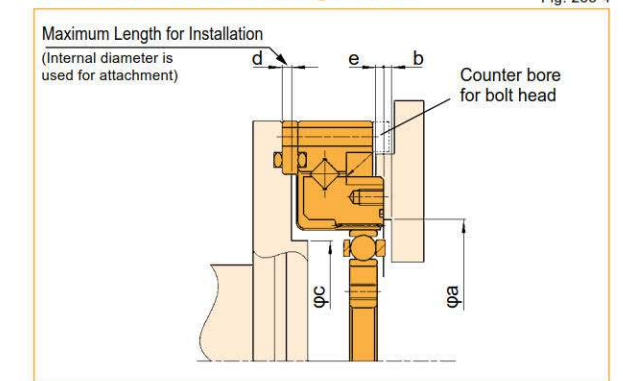

Minimum housing clearance

Table 283-5
Unit: mm

Symbol	Size	14	17	20	25	32	40
ϕa		36.5	45	53	66	86	106
b		1(3)	1(3)	1.5(4.5)	1.5(4.5)	2(6)	2.5(7.5)
ϕc		31	38	45	56	73	90
d		1.4	1.8	1.7	1.8	1.8	1.8
e		1.5	1.5	1.5	1.5	3.3	4

(Note) The value in parenthesis is the value when the wave generator is facing upward.

Application guide

As the SHD series is shipped with the outer race of the cross roller bearing and the flexspline temporarily bolted together, grease is applied to the gear teeth, the periphery of the flexspline and the tooth groove of the circular spline. Refer to the following application guide for grease application instructions.

Application guide

Table 284-1

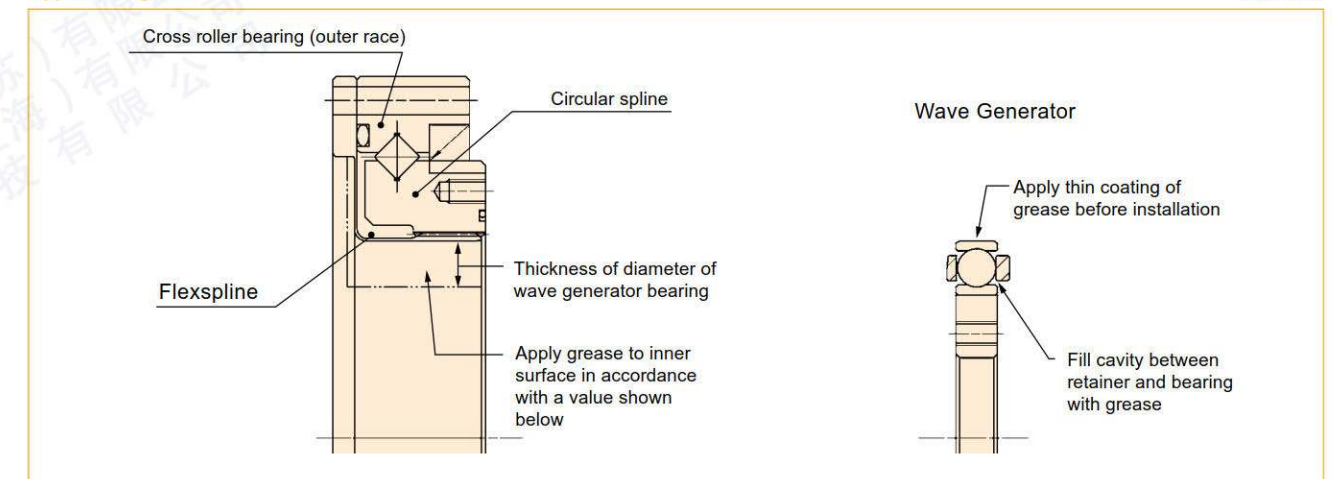

Application quantity

Table 284-1
Unit: g

Size	14	17	20	25	32	40
Application qty	5	9	13	24	51	99

Precautions on installation

■ Assembly order of the three basic elements

The wave generator is installed after the flexspline and circular spline. If the wave generator is not inserted into the flexspline last, gear teeth scuffing damage or improper eccentric gear mesh may result. Installation resulting in an eccentric tooth mesh (Dedoidal) will cause noise and vibration, and can lead to early failure of the gear. For proper function, the teeth of the flexspline and Circular Spline mesh symmetrically.

Assembly order for basic three elements

Fig. 285-1

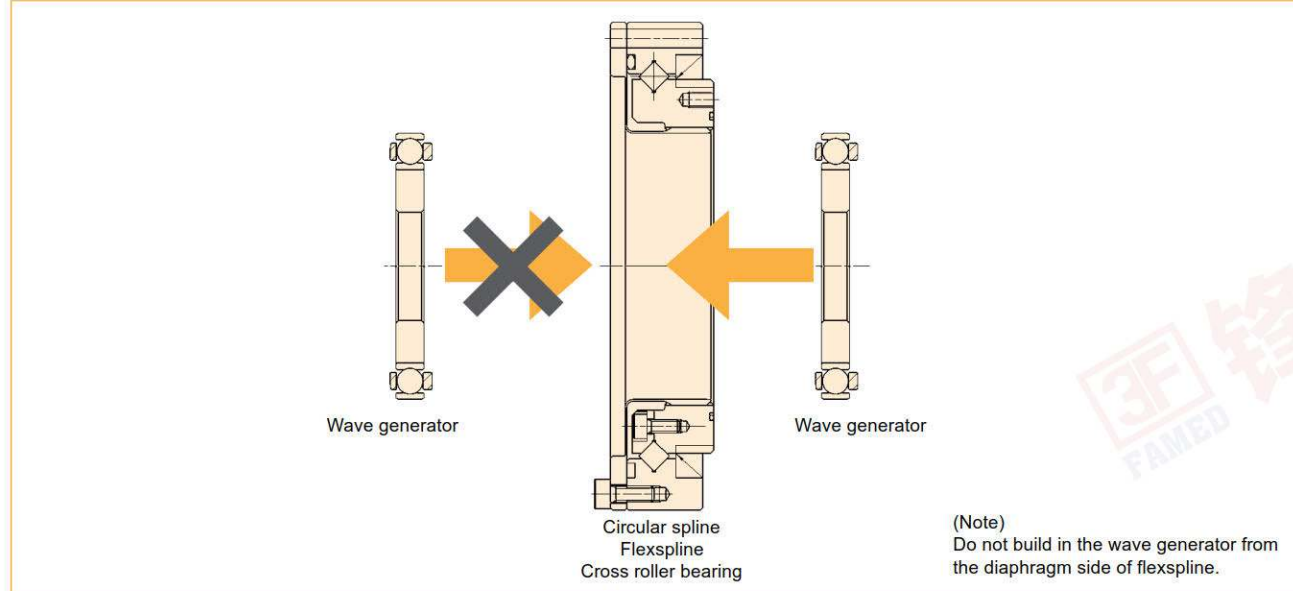

■ Precautions on assembly

It is extremely important to assemble the gear accurately and in proper sequence. For each of the three components, utilize the following precautions.

Wave generator

1. Avoid applying undue axial force to the wave generator during installation. Rotating the wave generator bearing while inserting it is recommended and will ease the process.
2. Extra care must be given to ensure that concentricity and inclination are within the specified limits (see page 281).
3. Installation bolts on the Wave Generator and Flexspline should not interfere each other.

Circular spline

The circular Spline must not be deformed in any way during the assembly. It is particularly important that the mounting surfaces are prepared correctly.

1. Mounting surfaces need to have adequate flatness, smoothness, and no distortion.
2. Especially in the area of the screw holes, burrs or foreign matter should not be present.
3. Adequate relief in the housing corners is needed to prevent interference with the corner of the circular spline.
4. The circular spline should be rotatable within the housing. Be sure there is not interference and that it does not catch on anything.
5. Bolts should not rotate freely when tightening and should not have any irregularity due to the bolt hole being misaligned or oblique.
6. Do not tighten the bolts with the specified torque all at once. Tighten the bolts temporarily with about half the specified torque, and then tighten them with the specified torque. Tighten them in an even, crisscross pattern.
7. Avoid pinning the circular spline if possible as it can reduce the rotational precision and smoothness of operation.

Flexspline

1. Mounting surfaces need to have adequate flatness, smoothness, and no distortion.
2. Especially in the area of the screw holes, burrs or foreign matter should not be present.
3. Adequate clearance with the housing is needed to ensure no interference especially with the major axis of flexspline
4. Bolts should rotate freely when installing through the mounting holes of the flexspline and should not have any irregularity due to the shaft bolt holes being misaligned or oblique.
5. Do not tighten the bolts with the specified torque all at once. Tighten the bolts temporarily with about half the specified torque, and then tighten them to the specified torque. Tighten them in an even, crisscross pattern.
6. The flexspline and circular spline are concentric after assembly. After installing the wave generator bearing, if it rotates in unbalanced way, check the mounting for dedoidal or non-concentric installation.
7. Care should be taken not to damage the flexspline diaphragm or gear teeth during assembly.
Avoid hitting the tips of the flexpline teeth and circular spline teeth. Avoid installing the CS from the open side of the flexspline after the wave generator has been installed.

Rust prevention

Although Harmonic Drive® gears come with some corrosion protection, the gear can rust if exposed to the environment. The gear external surfaces typically have only a temporary corrosion inhibitor and some oil applied. If an anti-rust product is needed, please contact us to review the options.

本公司产品的主要用途 Major Applications of Our Products



金属机床
Metal Working Machines



金属加工机械
Processing Machines



测定·分析·试验设备
Measurement, Analytical and Test Systems



医疗机械
Medical Equipments



望远镜
Telescopes



能源相关
Energy



包装·装箱设备
Crating and Packaging Machine



通信设备
Communication Equipments



航天设备
Space Equipments

Rover image created by Dan Maas, copyrighted to Cornell and provided courtesy NASA/JPL-Caltech.

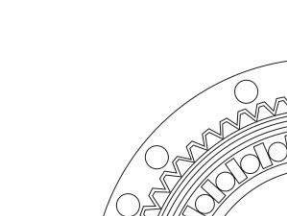

玻璃·陶瓷制造装置
Glass and Ceramic Manufacturing System



机器人
Robots

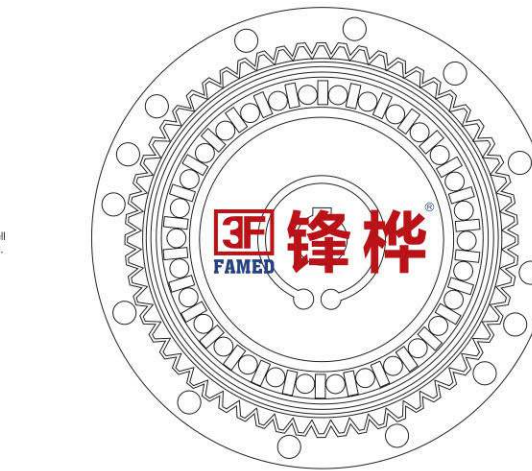

机器人
Humanoid Robots

提供：本田技研工业株式会社
Source: Honda Motor Co., Ltd.



印刷·装订·纸品加工机械
Printing, Bookbinding and Paper Machine

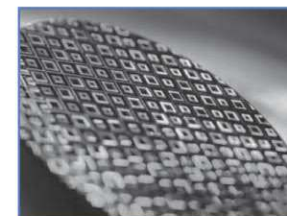

半导体制造装置
Semiconductor Manufacturing System



光学相关机械
Optical Machines



木材·轻金属·塑料加工机床
Wood, Light Metal and Plastic Machine Tool



制纸机械
Paper-making Machines



FPD制造装置
Flat Panel Display Manufacturing System

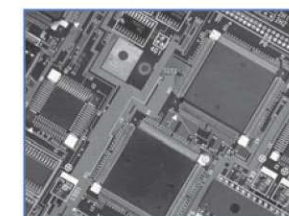

印刷电路制造装置
Printed Circuit Board Manufacturing Machine



航空器相关
Aircraft Technology